

# Kojtzijon pa Kaqchikel



COLECCIÓN

## Kaqchikel como segunda Lengua L<sup>2</sup>



*Ruka'n  
Rupalb'al  
Tijonik*

Segundo  
Primaria

E(DL)  
4  
4



— No'j

5120

**SE PROHIBE**  
Subrayar y/o marginar este libro,  
en caso de devolverlo subrayado,  
**SE COBRARA SU VALOR**

# Ruka'n Sik'iwuj richin Retamaxik ri kaqchikel ch'ab'äl

(Aprendamos el Idioma Kaqchikel)  
**Segundo Grado Primaria L2.**



**Kaqchikel Moloj/Fundación Kaqchikel**  
**K'amöl Taq b'ey /Junta Directiva**

Nab'ey K'amöl b'ey.	Presidente:	Héctor Rolando Gabriel Pichiya'
Ruka'n K'amöl b'ey.	Vicepresidente:	Julio Víctor Teleguario López
Ajtz'ib'.	Secretario:	Oswaldo Ajzalan Moráles
K'amöl b'ey pwäq.	Tesorero:	Rosalino Tichoc Cumes
Nab'ey to'onel.	Vocal I:	Ixchel, Justa Xinico Sipac
Ruka'n to'onel.	Vocal II:	Carlos Enrique Ajquiy Popol
Rox to'onel.	Vocal III:	Alejandro Asijtuj Simón

**K'amöl B'ey richin ri nuk'samaj**

"Runimik ri Ruchojmilal Tijonik pa taq tijonijay".  
Director: Programa de Educación Bilingüe Intercultural:  
"Incidencia en la Reforma Educativa desde el aula"  
Leopoldo Tzian.

**Re wuj re' xb'an pa Kaqchikel Moloj**  
Elaborado en la Fundación Kaqchikel.

**Xtz'ib'an:** María Luisa Curuchich

**Xeya'o' na'oj richin xtz'ib'äx, chuqa' xenik'on rupam re wuj re'**  
Revisión y Mediación pedagógica:  
María Esperanza Tuctuc Mux, José Alfredo López Sicaján,  
Carlos Marcial López, Mélida Xico Esquit y Abraham Gámez Paz.

**Xnik'o rutz'ib'axik:**

Kaqchikel Cholchi', Comunidad Lingüística Kaqchikel-CLK  
de la Academia de Lenguas Mayas de Guatemala, ALMG.

**Xeb'ano' ri achib'äl:** Emeterio Cuá, Julio Chalí, Hermelindo Mux,  
Elmer Heberto Colo.

**Xeya'on na'oj, xenik'on re wuj re':**

Asesoría y Revisión General: Junta Directiva de FUNKAQ y Dirección

**Xkinuk' rupam re wuj:**

Diseño, Diagramación e impresión  
Maya Na'oj

**Xeto'on rik'in ri pwäq:**

Con el apoyo de Unión Europea, Ibis/Dinamarca y Niños Refugiados del Mundo

Este texto se diseñó y se produjo en coordinación con la  
Dirección General de Educación Bilingüe Intercultural, DIGEBI.

S.U.E (Dh)  
401.4  
R934  
v.2.

# Rucholajem Wuj



Rupam	Ruxaq
Rutzij ri Kaqchikel Cholchi'	⋮ 4
Nab'ey taq tzij	5
Rub'eyal Rokisaxik re Wuj re'	·  6
<b>Nab'ey Tanaj:</b>	⋮ 7
Ri q'ejelonik	
<b>Ruka'n Tanaj:</b>	⋮ 19
Ri Qochoch	
<b>Rox Tanaj:</b>	· ·   31
Qatinamit.	
<b>Rukaj Tanaj:</b>	⋮ ⋮ 43
Ri nutijob'äl	
<b>Ro' Tanaj:</b>	⋮    55
Ri tzyaqb'äl	
<b>Ruwaq Tanaj:</b>	⋮ ⋮  67
Ri qach'akul	
<b>Ruwuq Tanaj:</b>	⋮ ⋮   79
Jalajöj ruwäch samaj	
<b>Ruwaqxaq Tanaj:</b>	⋮ ·   91
Jalajöj ruwäch tiko'n	
<b>Rub'elej tanaj</b>	⋮ 103
Ri chikopi'	
<b>Ch'uticholtzij</b>	⋮   113
Ri wuj xenik'ox	115

10-00  
BIBLIOTEKA CENTRAL (MUSCHIN) U.

Ri K'amöl B'ey richin ri Kaqchikel Cholchi', ruq'a' ri K'ulb'il Yol Twitz Paxil, nujikib'a' rutzij chuwäch re jun wuj re' chi:

Xnik'öx rutz'ib'axik ri qach'ab'äl chi kipam re wuj xkenatäx qa. Ruma k'a chi kipam ri jujun wuj kan pa rub'eyal b'anon chi re ri rutz'ib'axik ri qach'ab'äl. Re jun runik'oxik re' xb'an kuma ri rusamajela' ri Kaqchikel Cholchi'.

Richin nya'öx rejqalem re jun samaj re' nqaya' apo ri rujikib'axik qatzij pa ruwi' ri samaj.

La Infrascrita Presidenta de la Comunidad Lingüística Kaqchikel de la Academia de Lengua Mayas de Guatemala HACE CONSTAR que:

*Los textos educativos que abajo se mencionan, están escritos conforme a las reglas gramaticales actuales del idioma Kaqchikel, ya que los mismos fueron sometidos al proceso de revisión establecido en la entidad, por lo que los especialistas de la misma realizaron la revisión de la escritura del idioma Kaqchikel.*

### Modalidad L1

1. Comunicación y lenguaje Kaqchikel L1. Ruxe' Rupalb'al Tijonik. Preprimaria.
2. Comunicación y lenguaje Kaqchikel L1. Nab'ey Rupalb'al Tijonik. Primero Primaria.
3. Comunicación y Lenguaje Kaqchikel L1. Ruka'n Rupalb'al Tijonik. Segundo Primaria
4. Comunicación y Lenguaje Kaqchikel L1 Rox Rupalb'al Tijonik. Tercero Primaria.
5. Comunicación y Lenguaje Kaqchikel L1. Rukaj Rupalb'al Tijonik. Cuarto Primaria.

6. Comunicación y Lenguaje Kaqchikel L1. Ro' Rupalb'al Tijonik. Quinto Primaria.
7. Comunicación y Lenguaje Kaqchikel L1. Ruwaq Rupalb'al Tijonik. Sexto Primaria.

### Modalidad L2

1. Kojtzijon pa Kaqchikel. Comunicación y Lenguaje Kaqchikel. L2. Nab'ey Rupalb'al Tijonik. Primero Primaria.
2. Kojtzijon pa Kaqchikel. Comunicación y Lenguaje Kaqchikel. L2. Ruka'n Rupalb'al Tijonik. Segundo Primaria.

Para los usos legales que a la institución convenga, extendiendo, firmo y sello la presente en una hoja de papel bond, a los cinco días del mes de abril del año 2004.

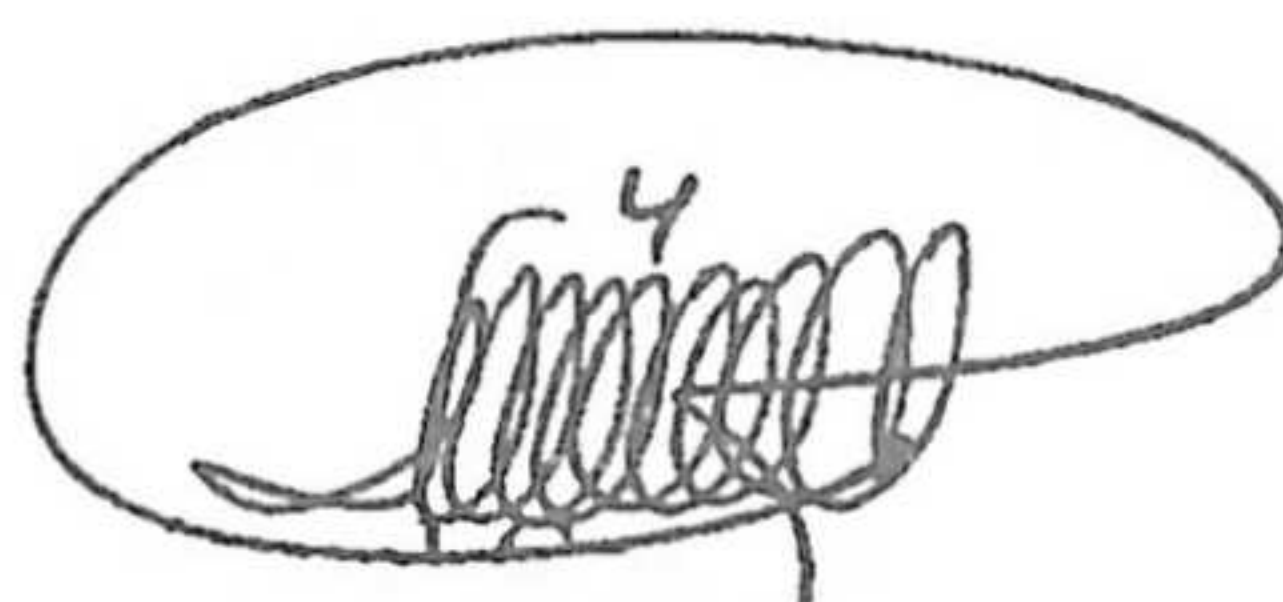

María del Carmen Tuy Tococho  
Presidenta Comunidad Lingüística Kaqchikel



## Nab'ey taq tzij



Ruka'n sik'iwuj richin retamaxik ri kaqchikel ch'ab'äl.

Chupam ri Kaqulew e k'äs maya' winaqi' chuqa' kaxlan taq winaqi'. Ruma ronojel q'ij nkitzu' ki', nkich'ab'ej ki' ruma ri' ruk'amon ta chi yech'o pa maya' ch'ab'äl, richin man xa xe ta ri kaxlan nya'ox ruq'ij.

Ruma ri' ri kaqchikel Moloj nurayb'ej chi ri winaqi' e k'äs chupam ri Kaqulew yetikir ta yech'o pa ka'i' ch'ab'äl ruma ri' nusamajij jun peraj tijonik kik'in ri tijoxela' man xketamaj ta ri kaqchikel ch'ab'äl kik'in ri kite' kitata'.

Re wuj re' ruximon pe ri' rik'in ri nab'ey sik'iwuj richin retamaxik ri kaqchikel ch'ab'äl, chuqa' tikirel nrokisaj jun winäq jun ak'wal ri nrajo' nretamaj ri kaqchikel ch'ab'äl.

Ri Kaqchikel Moloj nroyob'ej chi re wuj re' xtib'eruto' ta ri tijonik kik'in ri tijoxela', chuqa' xkeb'eruto' ta ri tijonela' richin xketikir ta xtikinimirisaj ruwäch kik'in k'ak'a' taq na'oj chuqa' richin ke ri' man xa xe' re wuj re' xtikokisaj, ruma ri tijonik ütz nb'an jalajöj rub'eyal chi re, achi'el rik'in jalajöj wachinäq chuqa' rik'in rusolik ri ch'akulaj, kik'oxomal jalajöj taq wachinäq chikopi' ri e k'äs chuwäch re ruwach'ulew.

## Rub'eyal rusamajixik re wuj



Re jun sik'iwuj re' k'o b'eleje' tanaj chupam. Ri Nab'ey Tanaj nch'o chi rij ri q'ejelonik, ri ruka'n tanaj: Ri Qochoch, Rökx Tanaj: Ri Qatinamit, Rukaj Tanaj: Ri nutijob'al, Ri Ro' Tanaj: Ri tzyaqb'al, Ruwaq Tanaj: Ri qach'akul, Ruwuq Tanaj: Jalajöj ruwäch samaj, Ruwaqxaq Tanaj: Jalajöj ruwäch samaj, Rub'elej tanaj Ri chikopi'. Pa jujun tanaj xokisäx na'oj richin ruk'utik ri kaqchikel ch'ab'al.



Ri wetaman chik:

Wawe' ntok we ronojel ri etamab'al ruk'amon pe ri tijoxel chi rochoch.



Ri ninwetamaj:

Chupam re jun peraj na'oj re', ye'ok ri na'oj ri xtib'eretamaj ri tijoxel pa tijob'al.



Ri xinwetamaj.

Chupam re jun peraj re' nqatz'ët ronojel ri tijonik xretamaj ri tijoxel.

Chuqa' xokisäx jun ka'i' oxi' rub'eyal richin rusamajixik rub'eyal ruk'utik ri ch'ab'al.

Pa ruk'isb'al xokisäx jujun taq na'oj richin ruk'utik jun ch'ab'al: **Tqak'axaj:** Ri tijoxel xa xe nrak'axaj ri nub'ij ri rutijonel. **Tqatzu':** Nutzu' chuqa' nrak'axaj ri etamab'al. **Tqab'ij:** K'o chi nkamuluj ri nub'ij ri tijonel chi re. **Kojtzijon:** Ntzijon kik'in ri rachib'il, chuqa' pa taq molaj. **Tqasik'ij:** Nusik'ij ri achib'al chuqa' jalajöj taq tzij ri nk'utux chi re. **Tqatz'ib'aj:** nutz'ib'aj jalajöj taq na'oj ri nk'utux chi re ruma ri rutijonel.

Ri tijonel jantape' trokisaj jalajöj taq etz'anem, b'ix, pach'un tzij richin ruk'utik ri kaqchikel ch'ab'al.

# NAB'EY TANAJ

## RI Q'EJELONİK



### Ri etamanik nuq'i' ri tijoxel:

Nutz'et, nrak'axaj ri q'ejelonik pa qach'ab'äl.  
Nretamaj na'ejelon pa qach'ab'äl  
Nretamaj ruwäch jalajöj taq q'ejelonik  
Nuch'ob' chuqa' nretamaj ntz'ib'an pa qach'ab'äl.

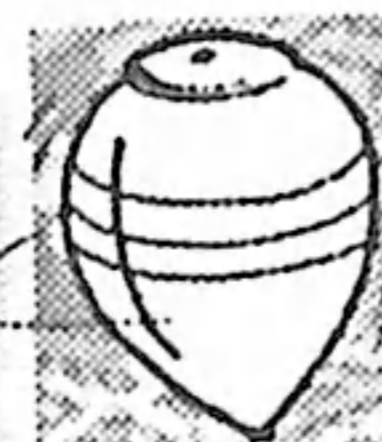
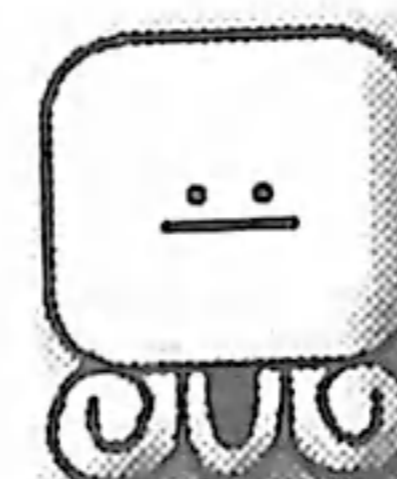
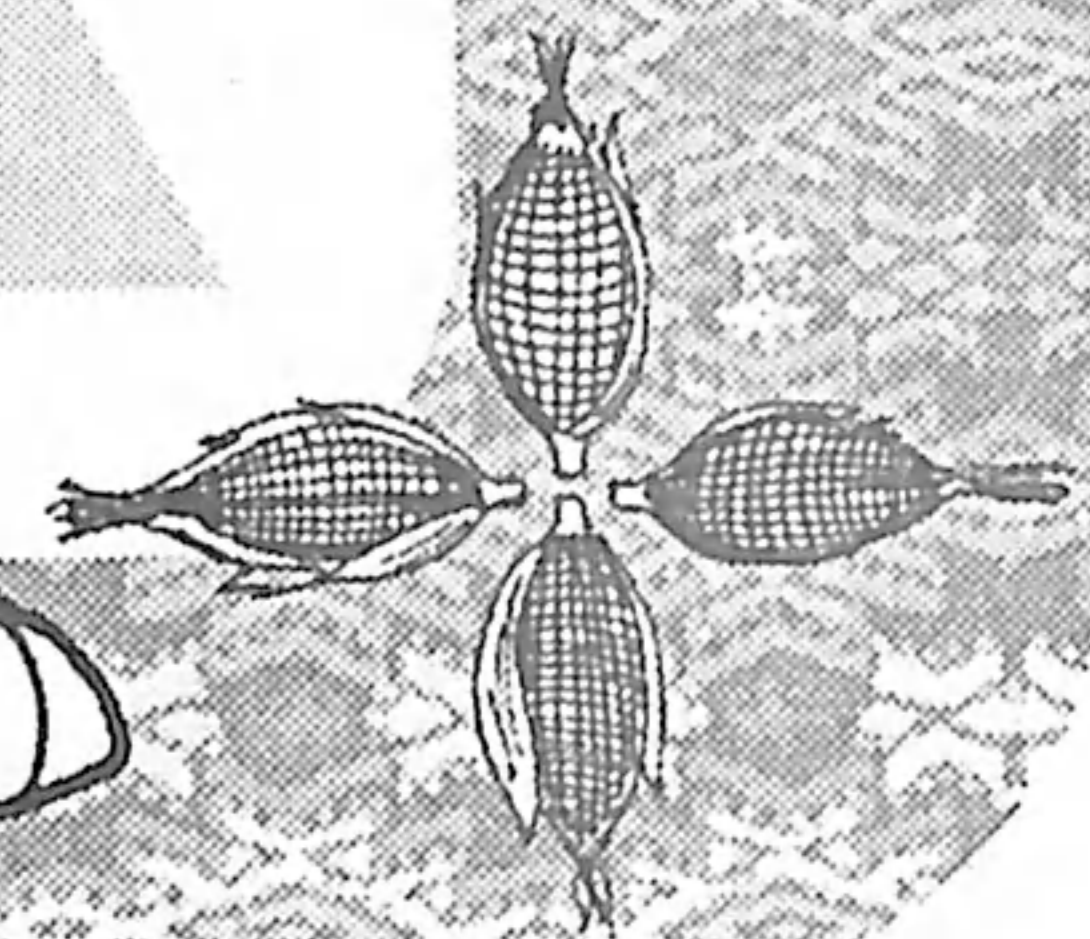
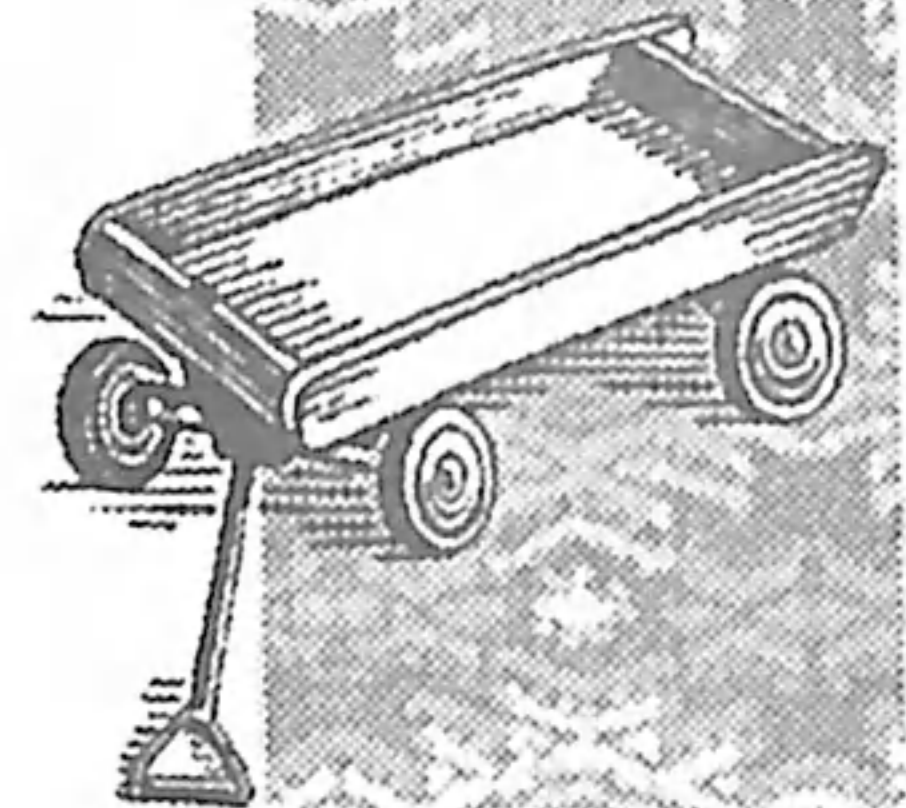
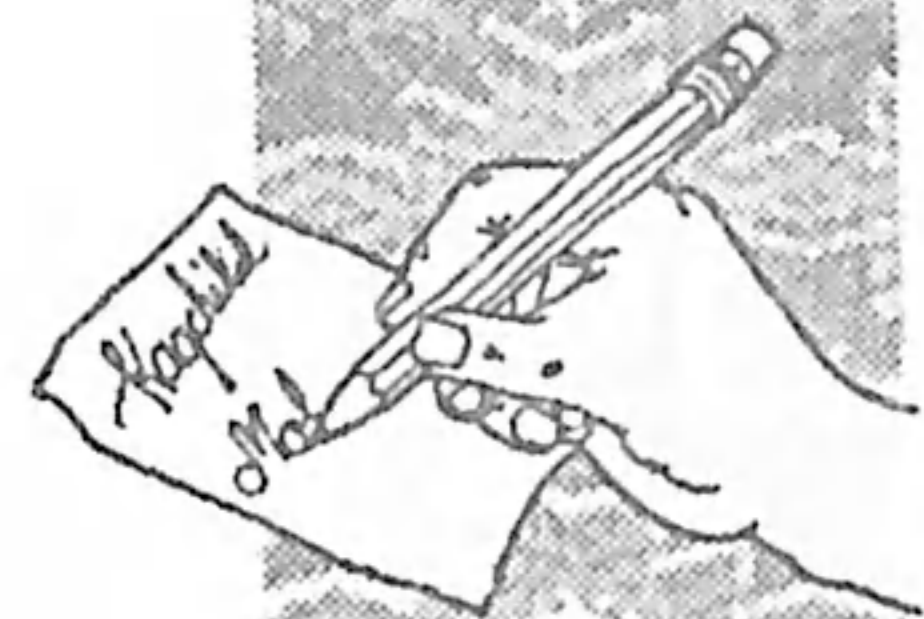



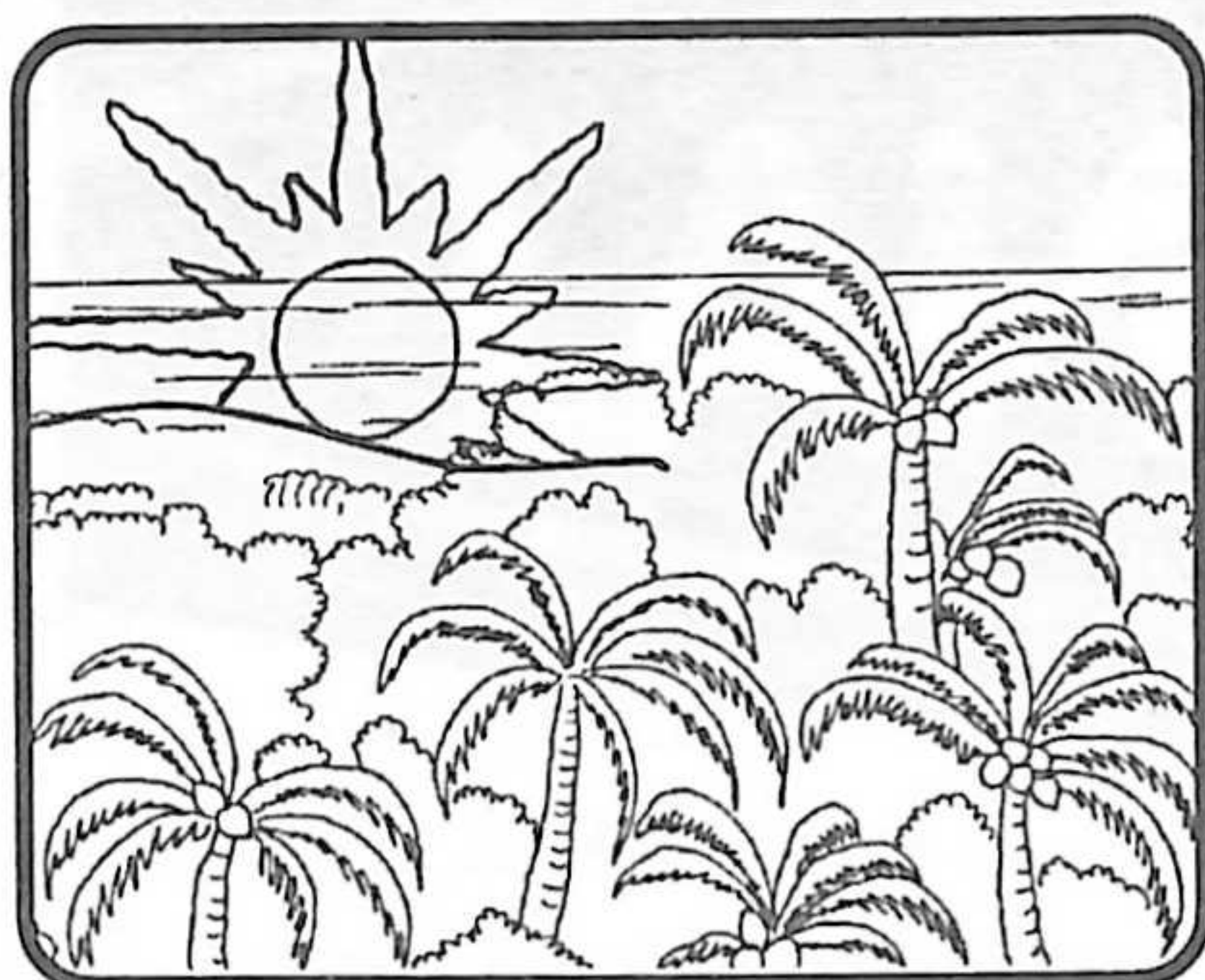

Xsaqër



xqaaq'ij

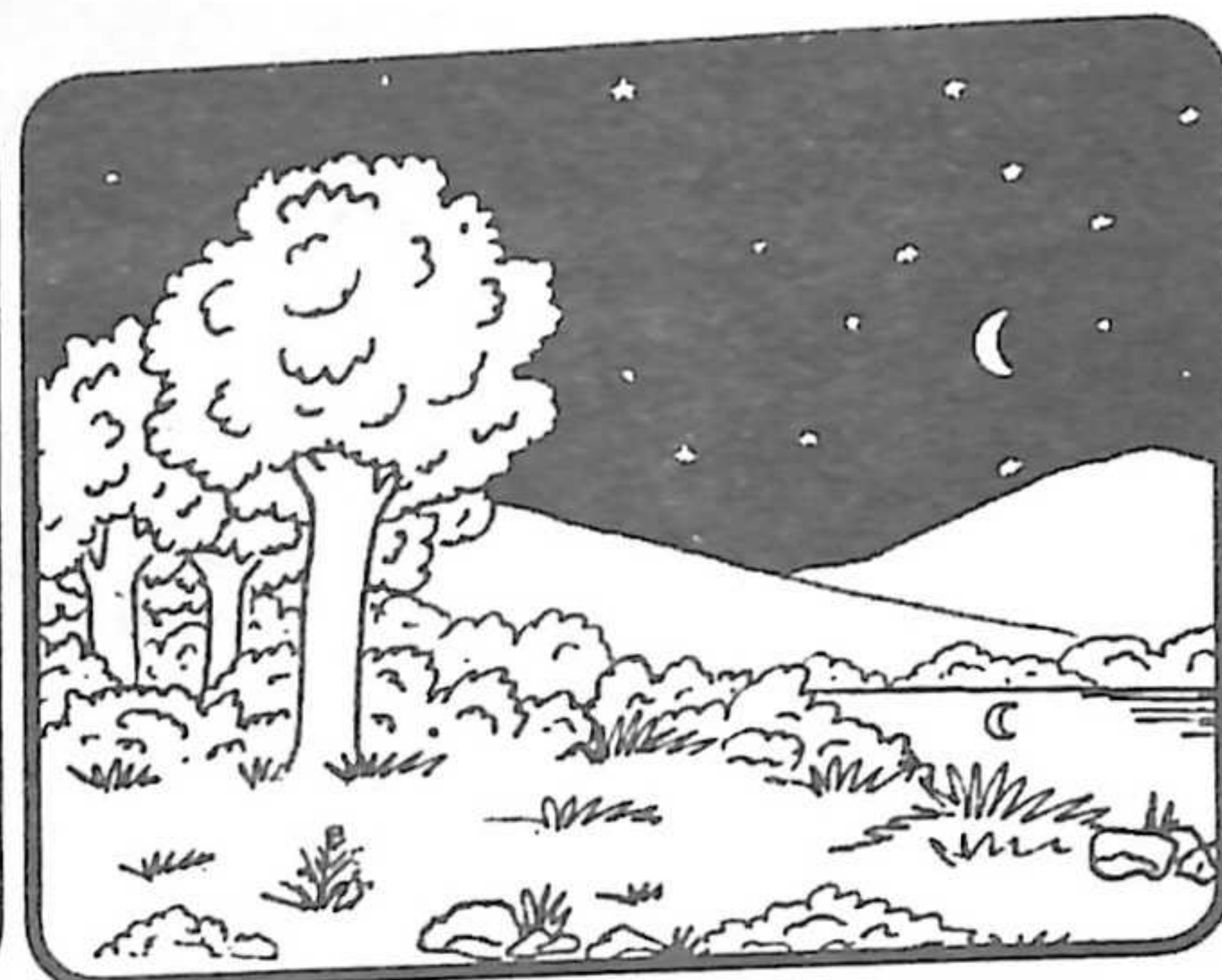

xokaq'a'

Tqakamuluj

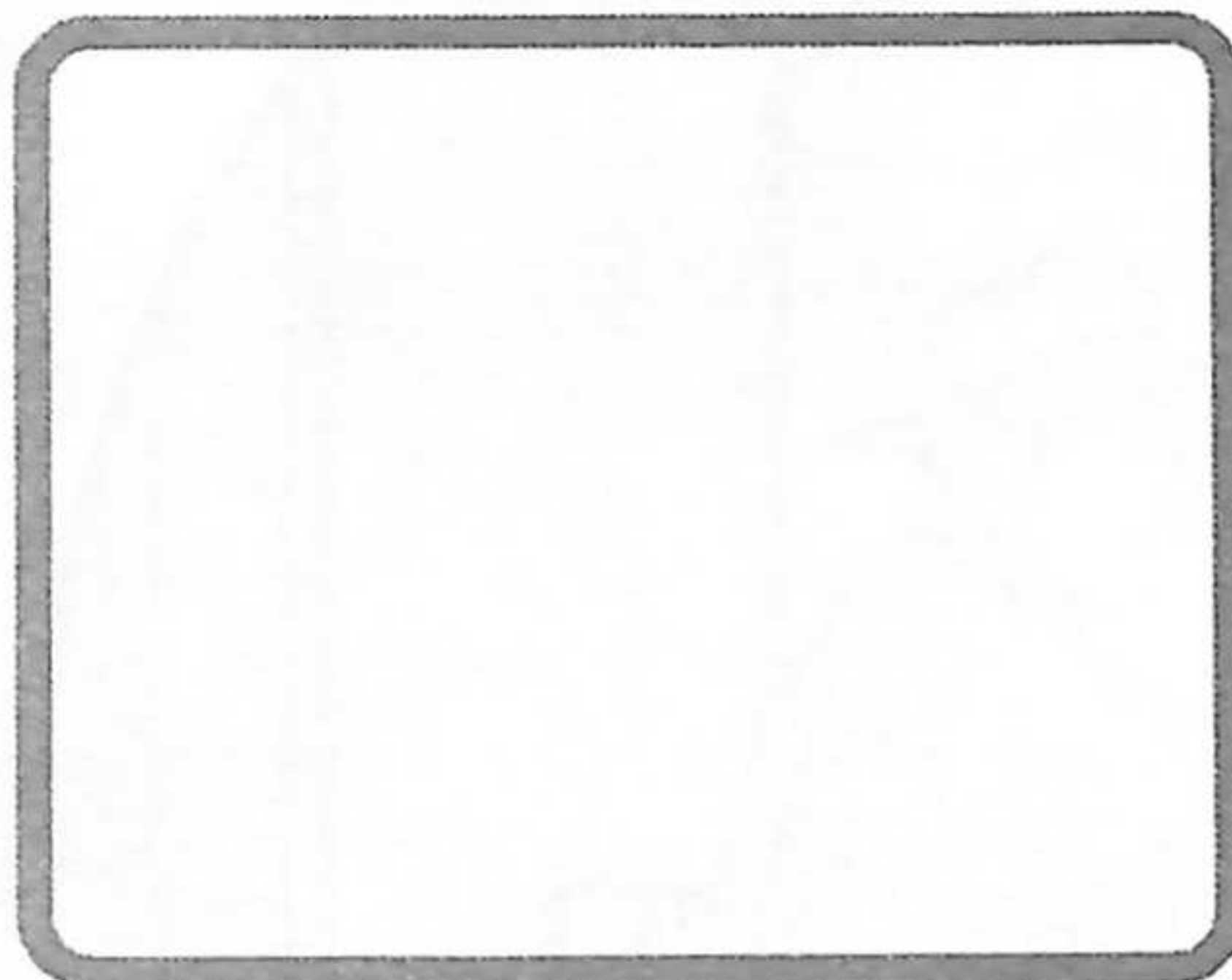

Xsaqër

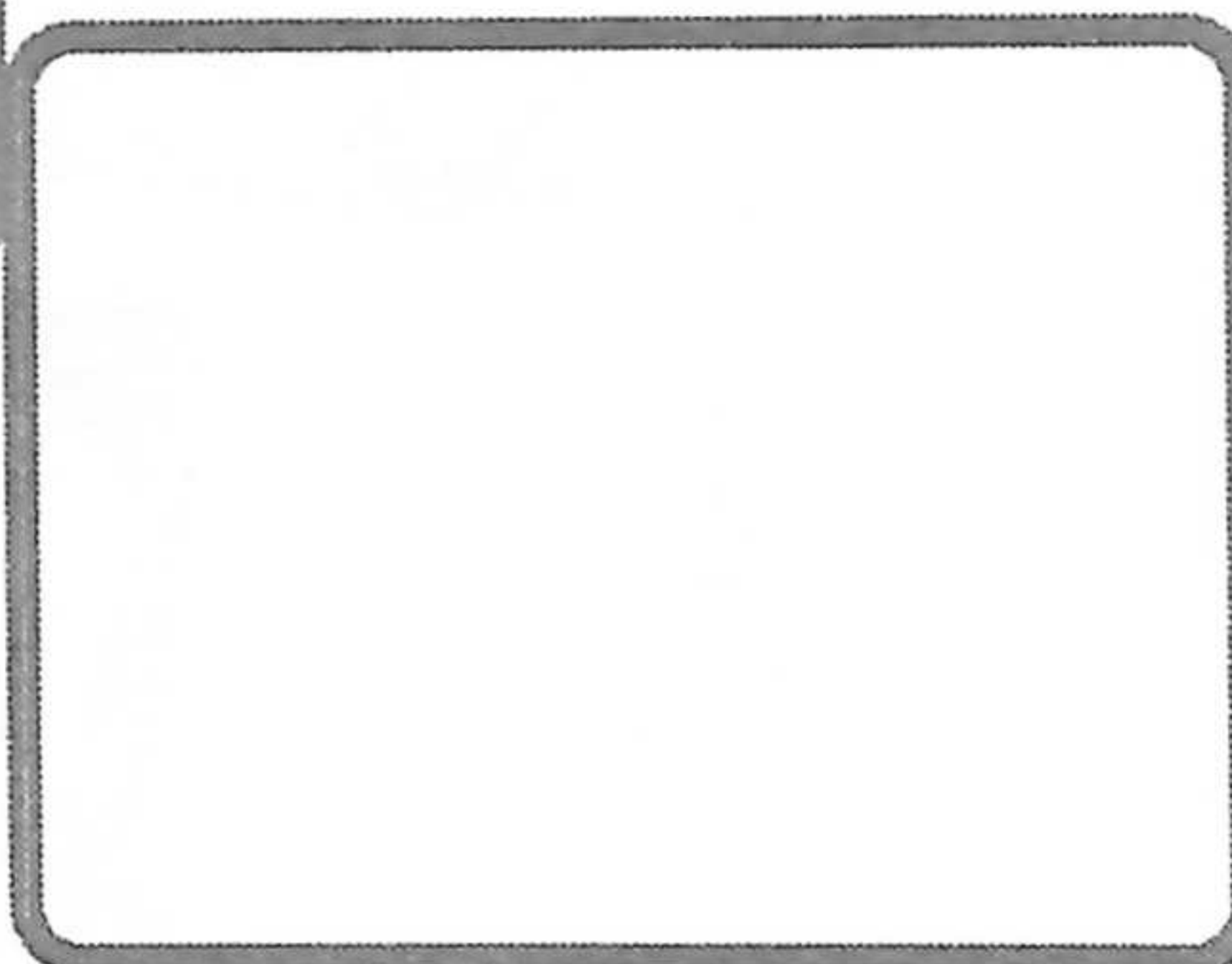

xqaaq'ij

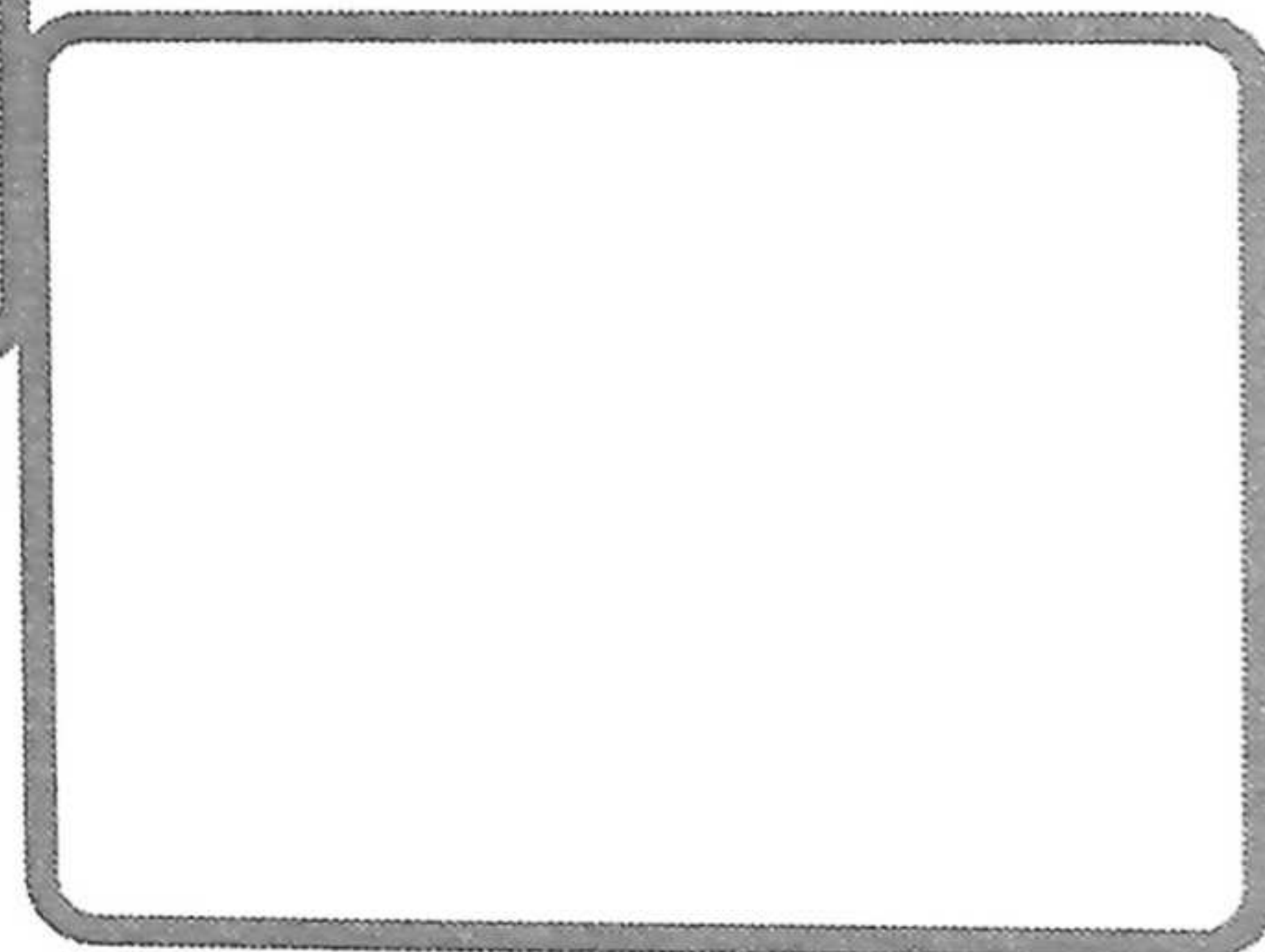

xokaq'a'

Ri tijonel nusöl chi kiwäch ri tijoxela' achike nuq'ajuj ri jujun achib'äl, k'a ri' ri tijoxela' nkak'axaj richin nkikamuluj jujun taq tzij, chuqa' k'atzinel nkik'ut ri taq achib'äl richin nketamaj ri jalajöj ruwäch q'øjelonik.



¿Achike ramaj k'o pa ri nab'ey, ruka'n, chuqa' ri rox

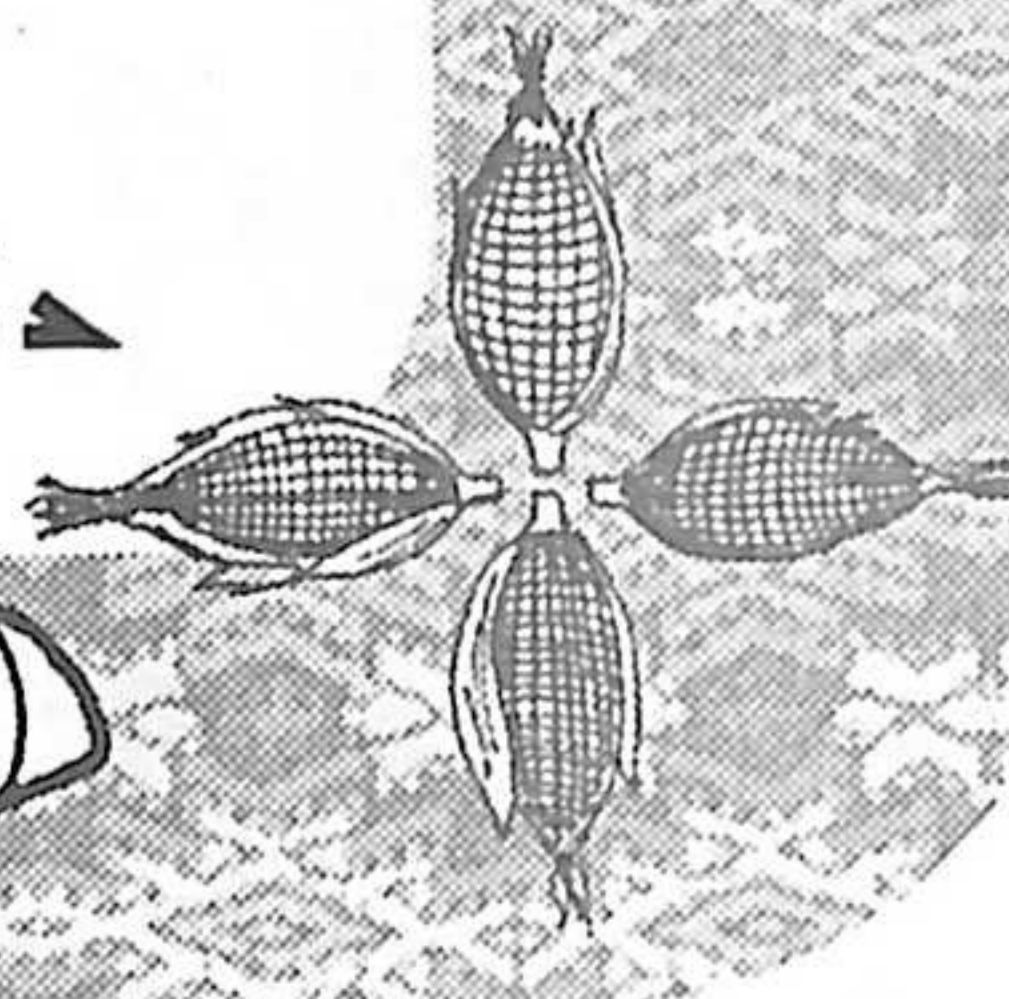
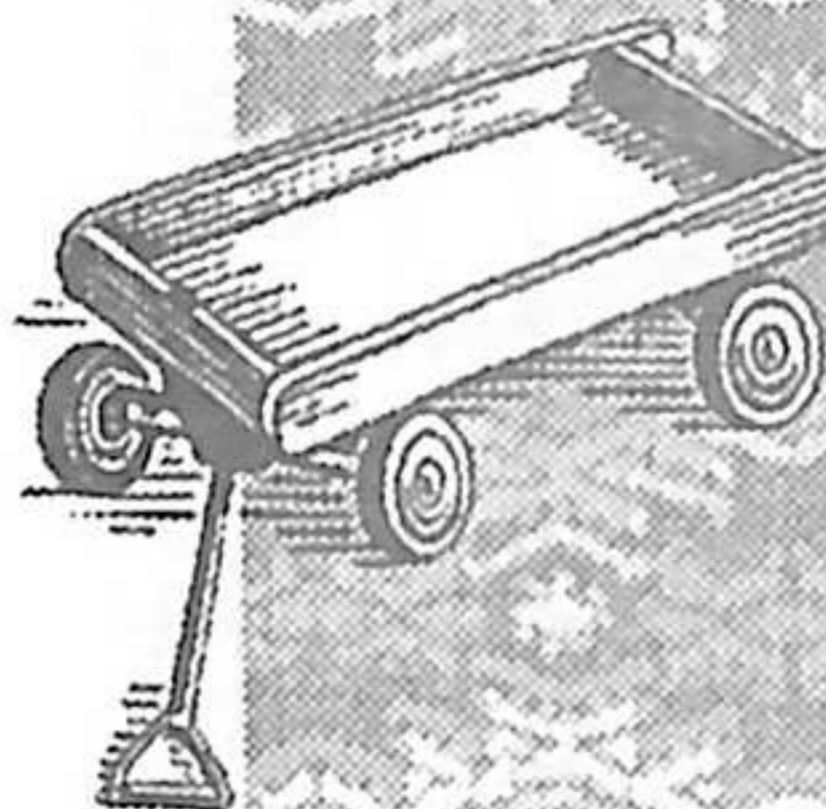
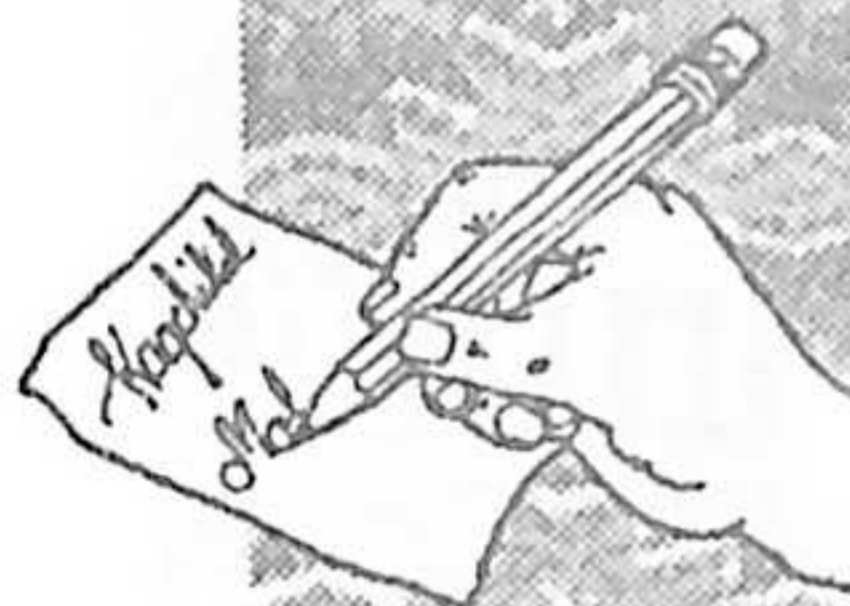
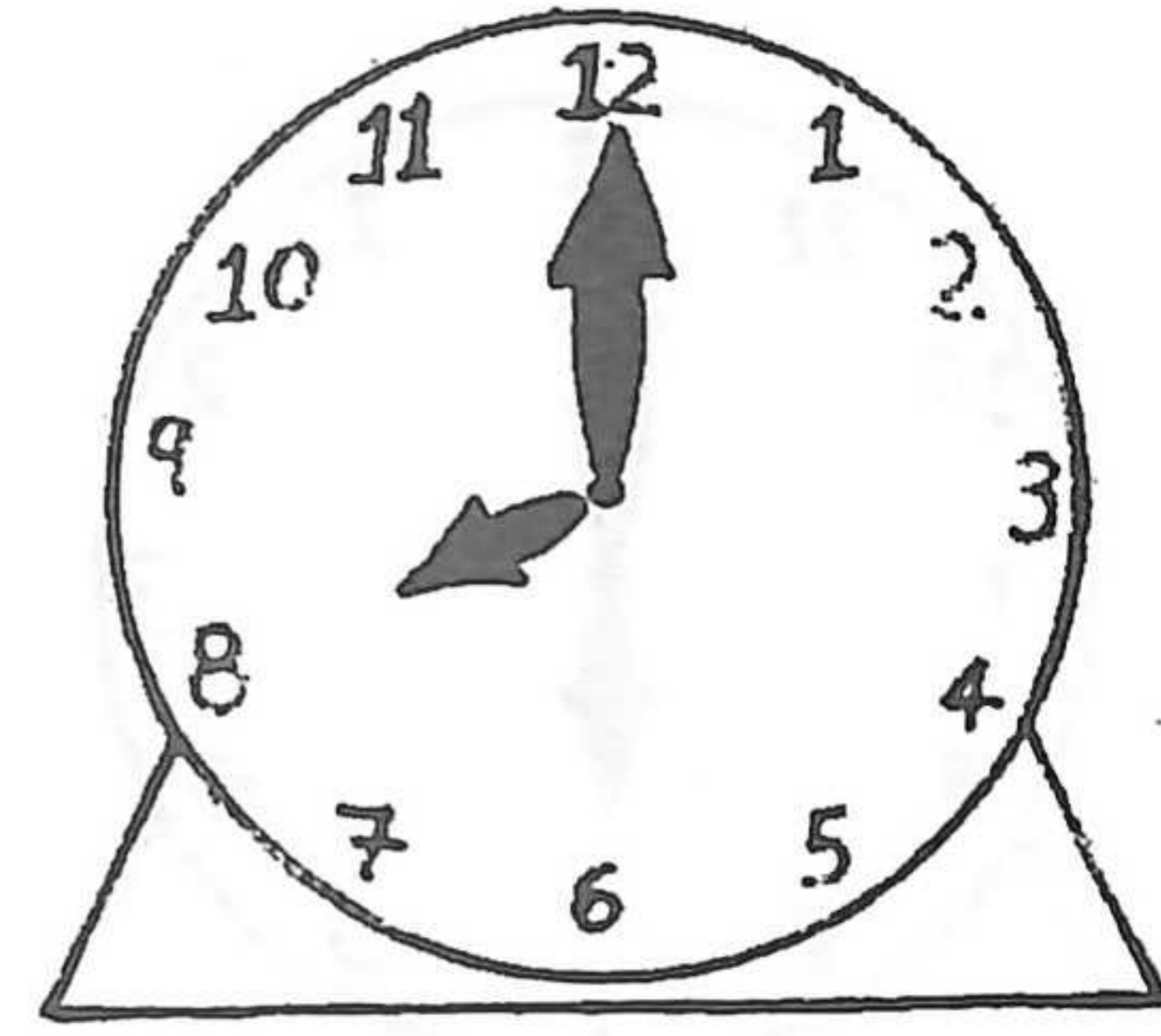
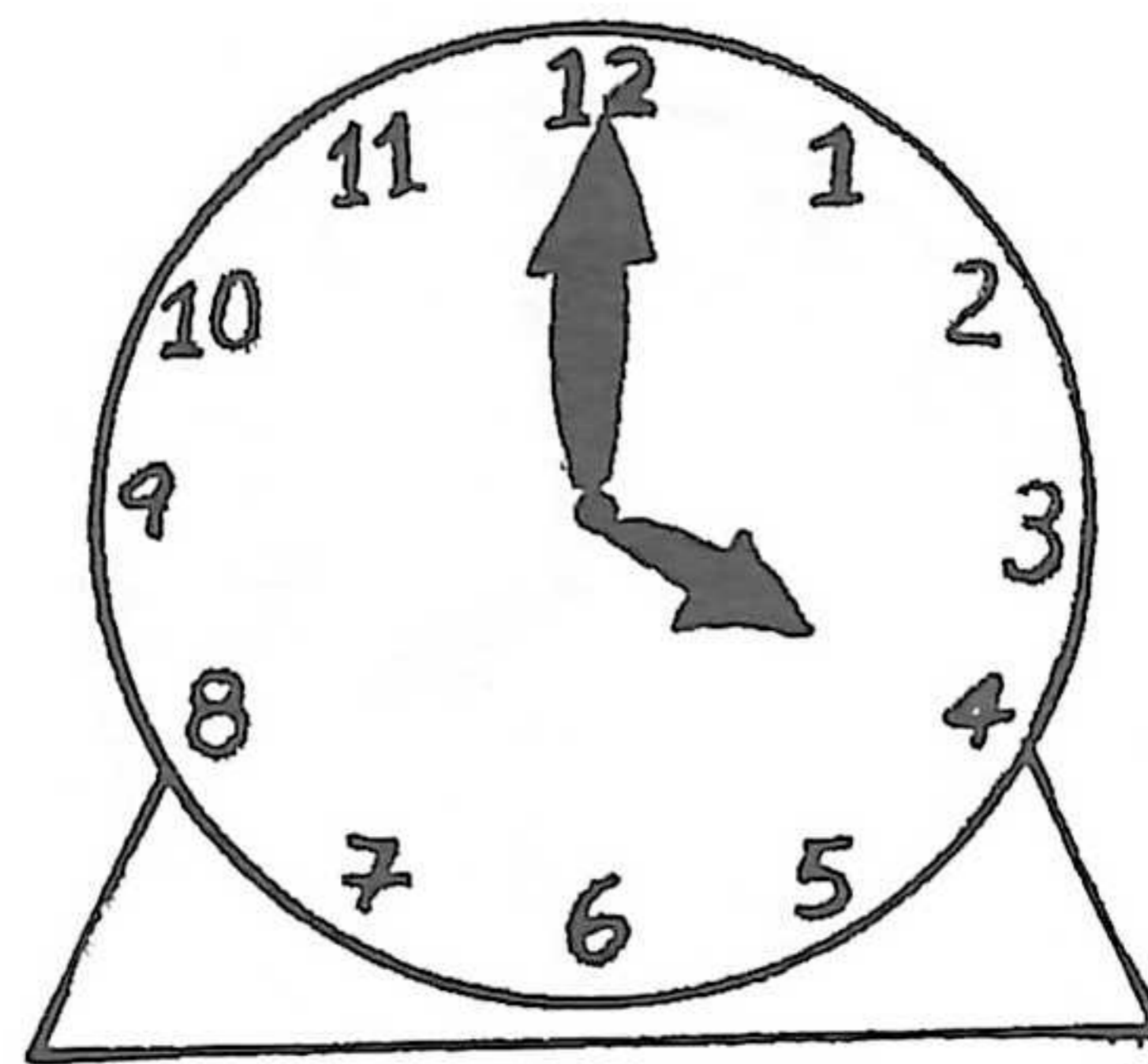
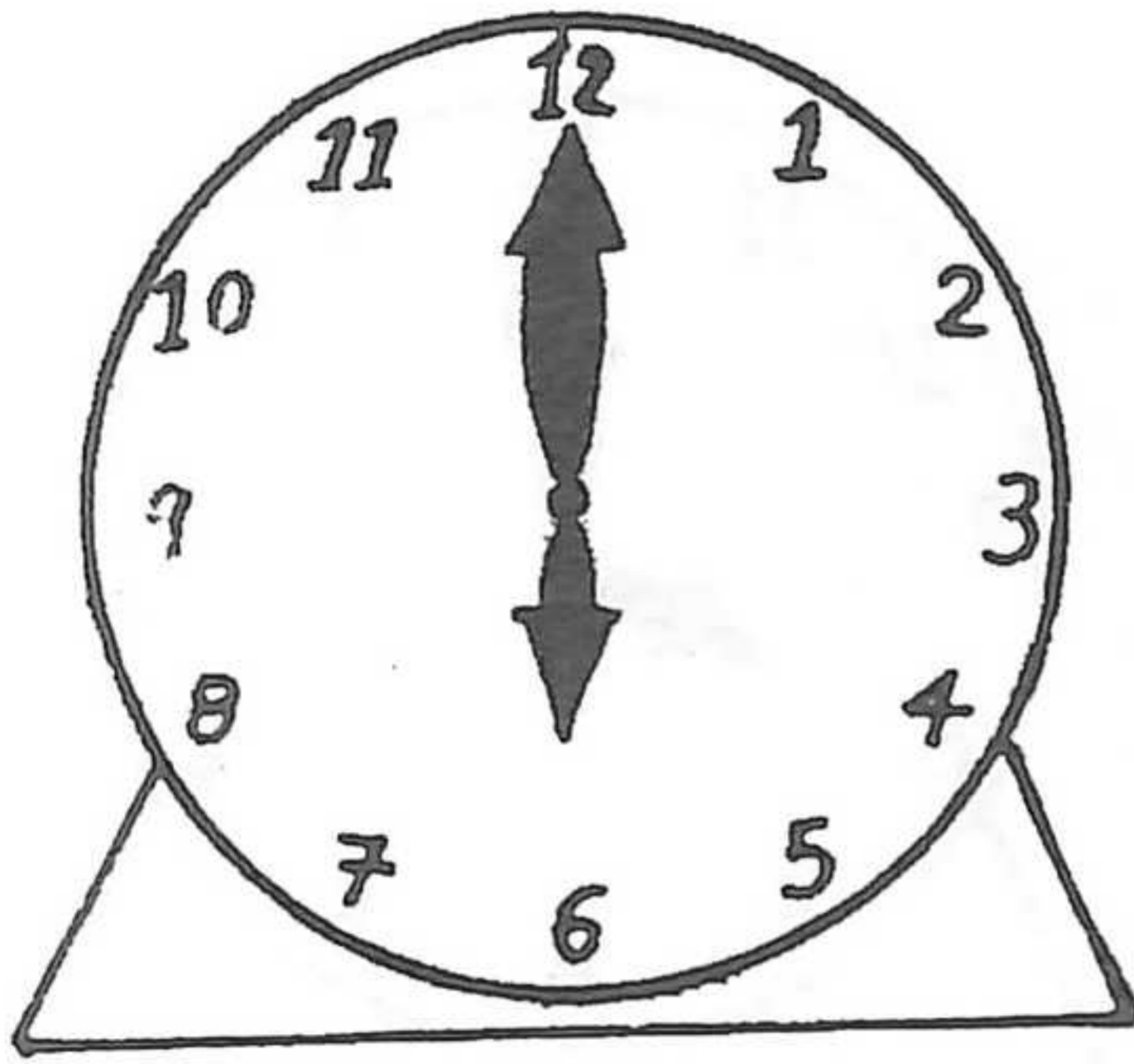

Pakal



q'ijob'äl

- Ixchel: Xsaqër Ixq'anil
- Ixq'anil: Xsaqër Ixchel
- Pakal: Xsaqër Ixchel
- Ixchel: Xsaqër Pakal
- Ixq'anil: Xsaqër Pakal.
- Pakal: Xsaqër Ixq'anil

Kojtzijon:

Ixmukane: \_\_\_\_\_ Saqitel.

Saqitel: \_\_\_\_\_ Ixmukane

Ri tijonel k'o chi nukamuluj ri q'ejelonik kik'in ri tijoxela'.

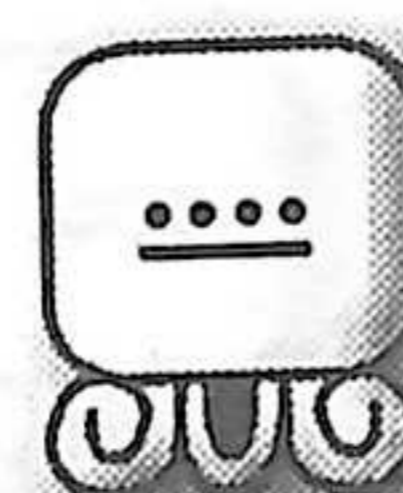

# Tqatzu' chuqa' Tqak'axaj

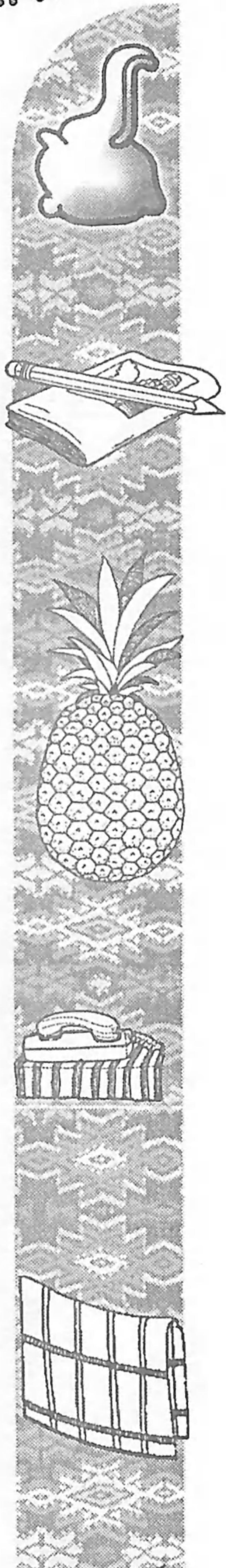
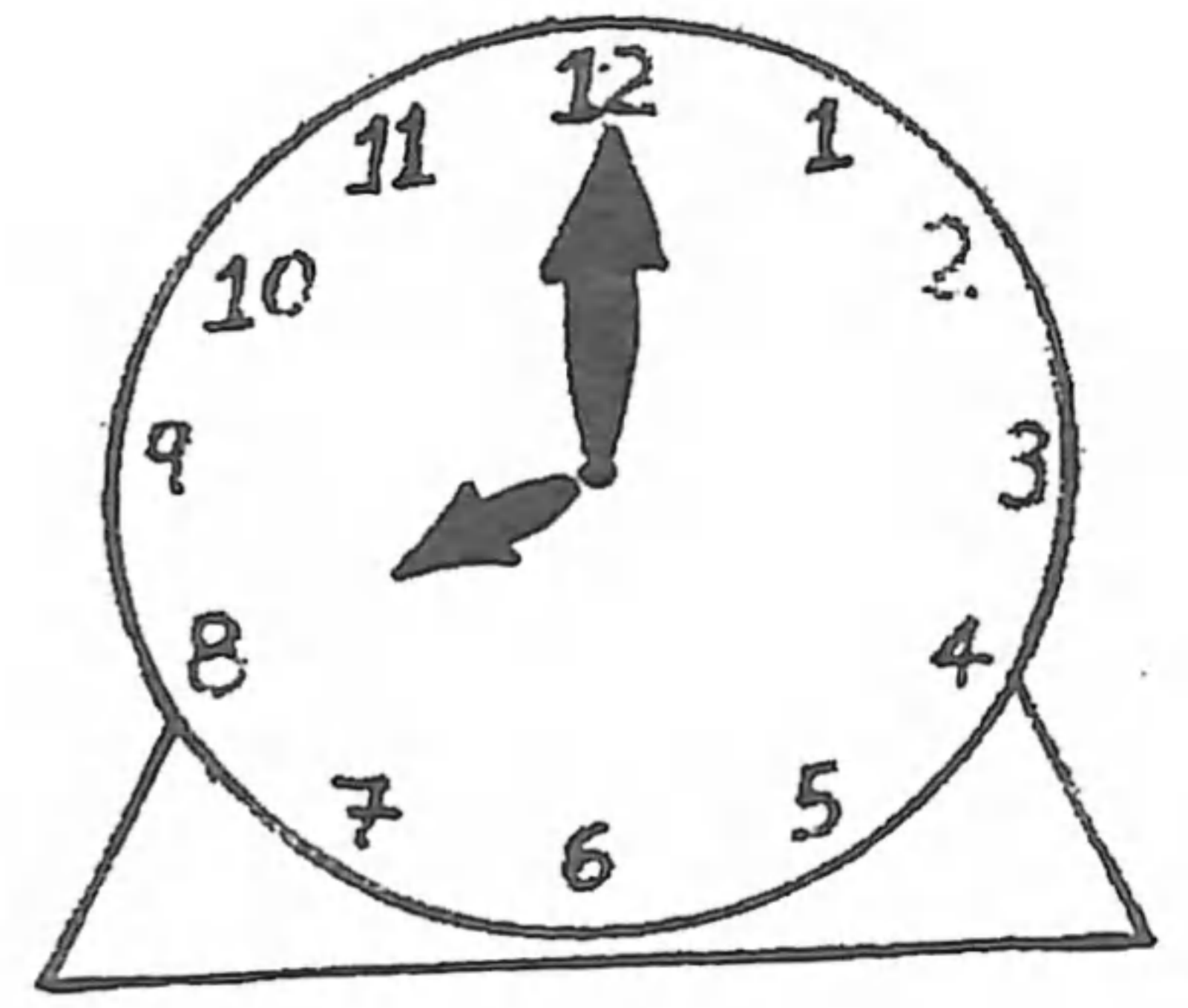
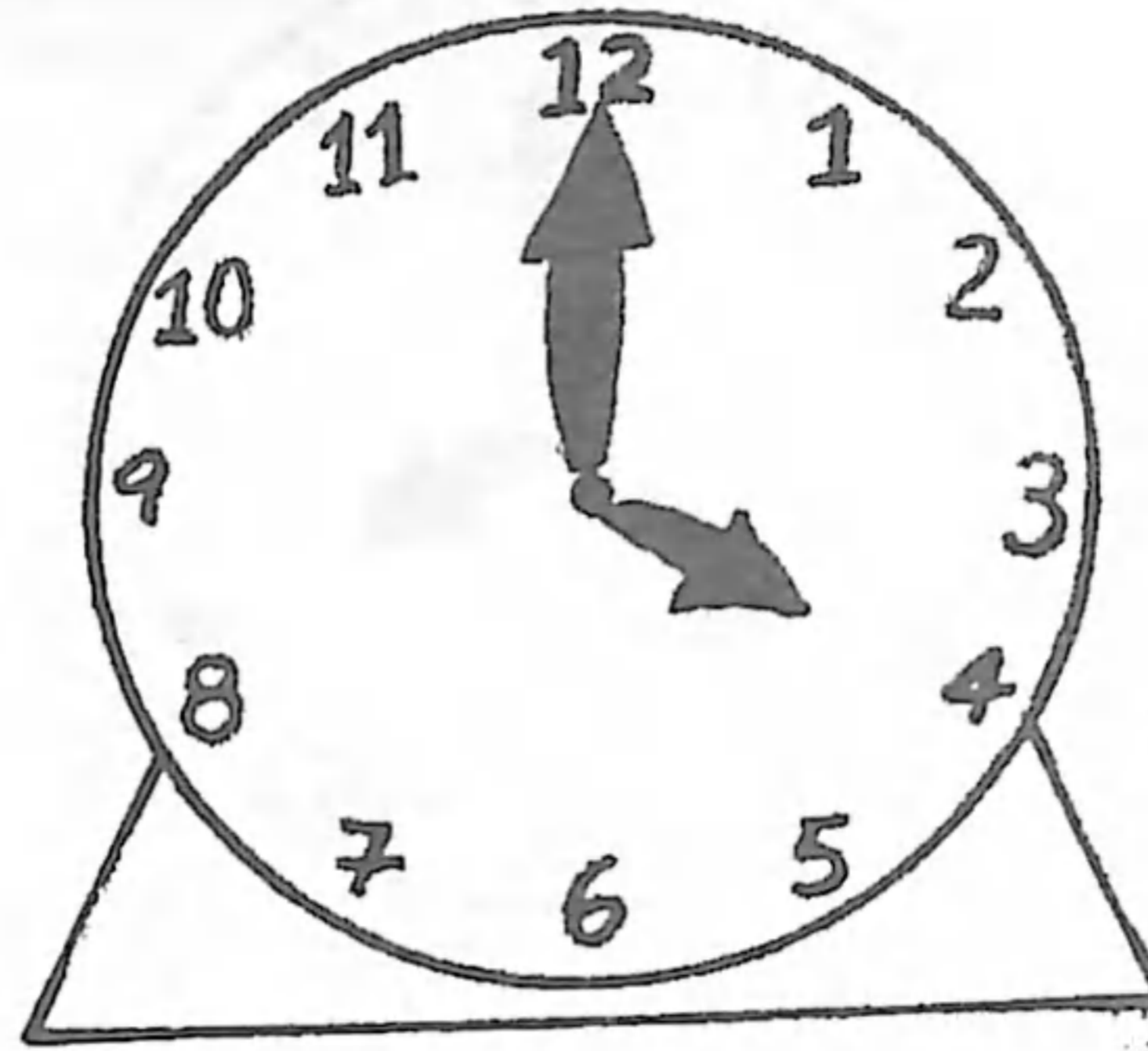
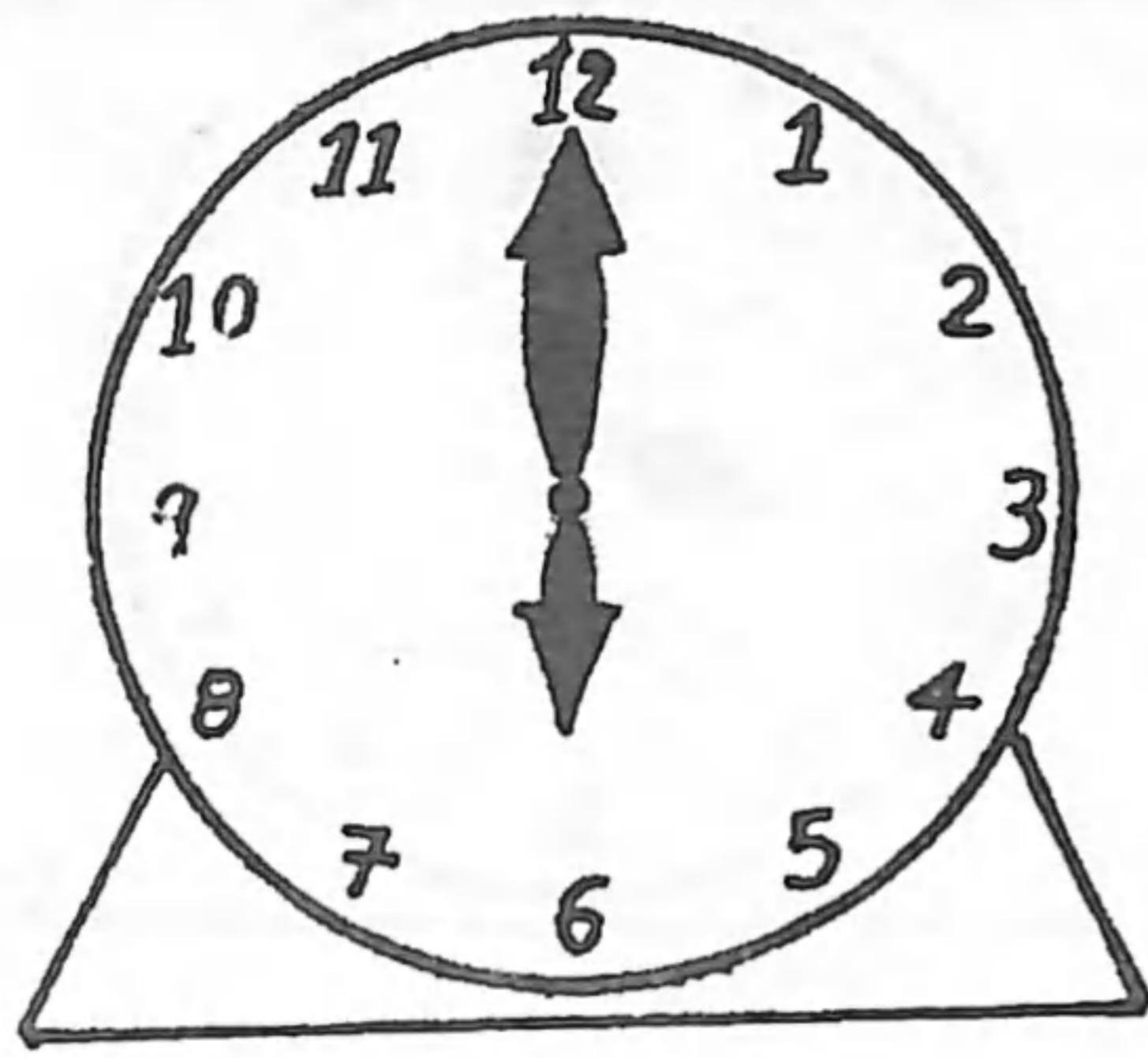

Xwan: Xqaaq'ij Lu', ¿ütz awäch?  
 Lu': Xqaaq'ij Xwan, üt matyox.  
 Xwan: ¿La üt awäch rat?  
 Lu': Ütz matyox,  
 Xwan: Matyox k'a ri'

Kojtzijon:

Junajpu': ..... Ajpop  
 Ajpop: ..... Junajpu'

1 Ri tijonel k'atzinel yeruto' ri tijoxela' richin nkitzu' chuqa' nkak'axaj ri jalajöj ruwäch taq q'ejelonik.

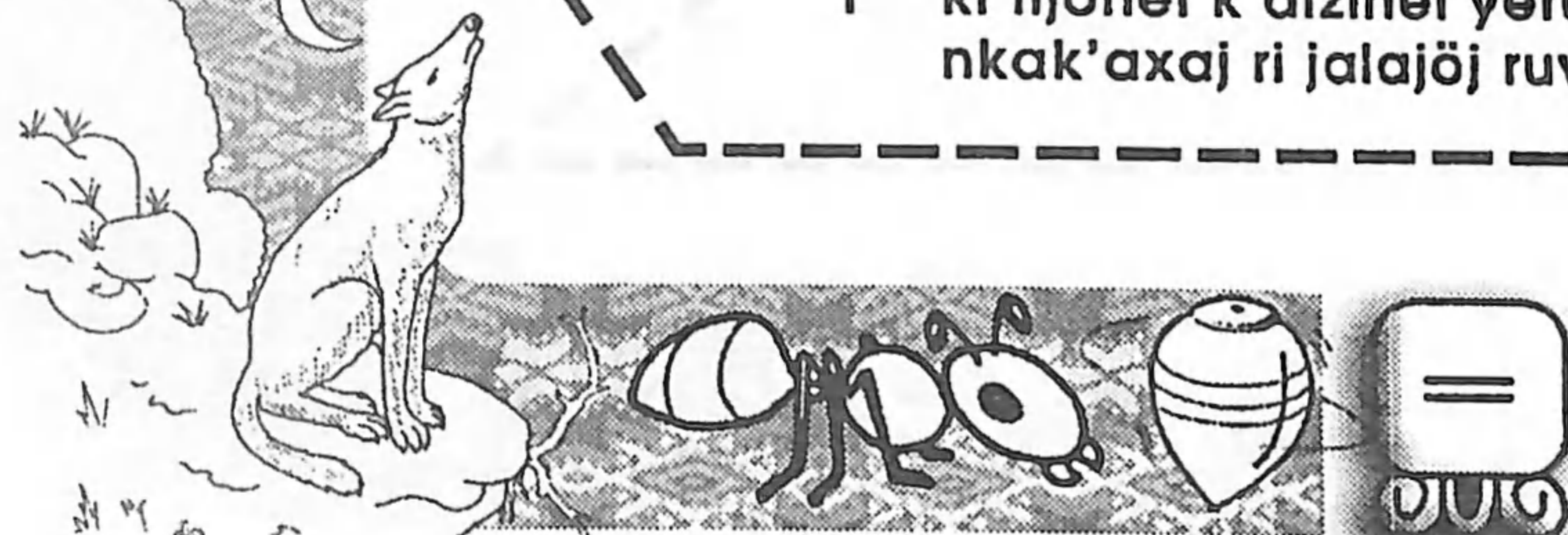

# Tqatzu'



Ixkoq'ij: Xsaqër Nik'te, ¿ütz awäch?  
 Nik'te: Xsaqër Ixkoq'ij, ütz matyox.  
 Ixkoq'ij: ¿Ütz awäch rat?  
 Nik'te: Ütz matyox  
 Ixk'oq'ij: Matyox k'a ri'  
 Nik'te: Akuchi yatb'e wi  
 Ixkoq'ij: Rin yinb'esamäj.

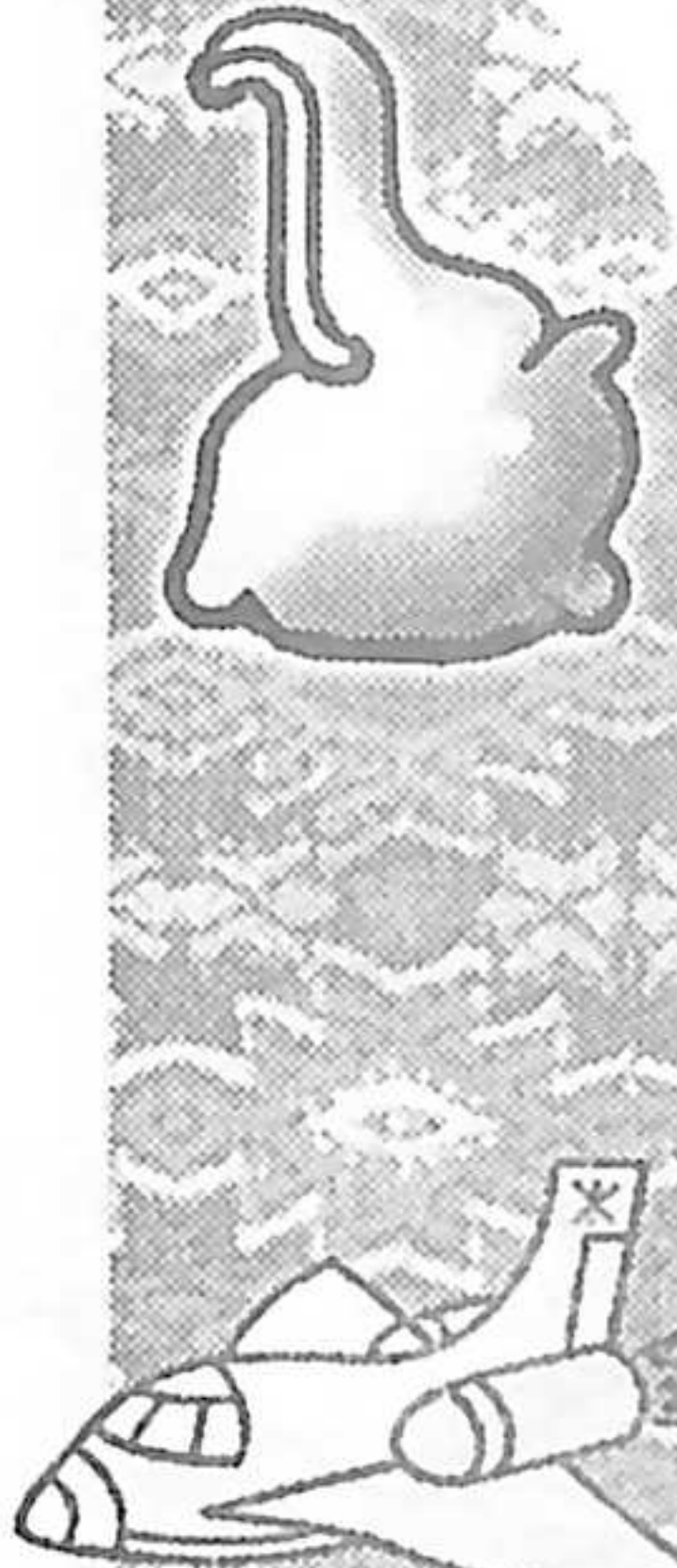

Kojtzijon:

Ixq'o'j: \_\_\_\_\_ Ixkanul  
 Ixkanul: \_\_\_\_\_ Ixq'o'j



Ixtän

Ala'

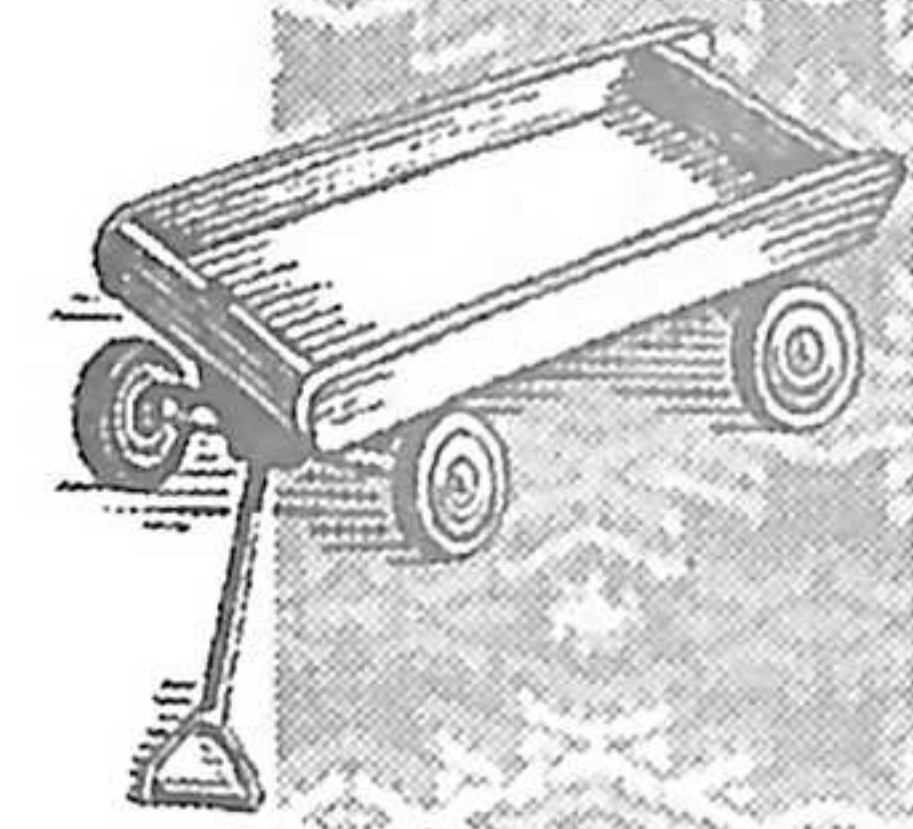
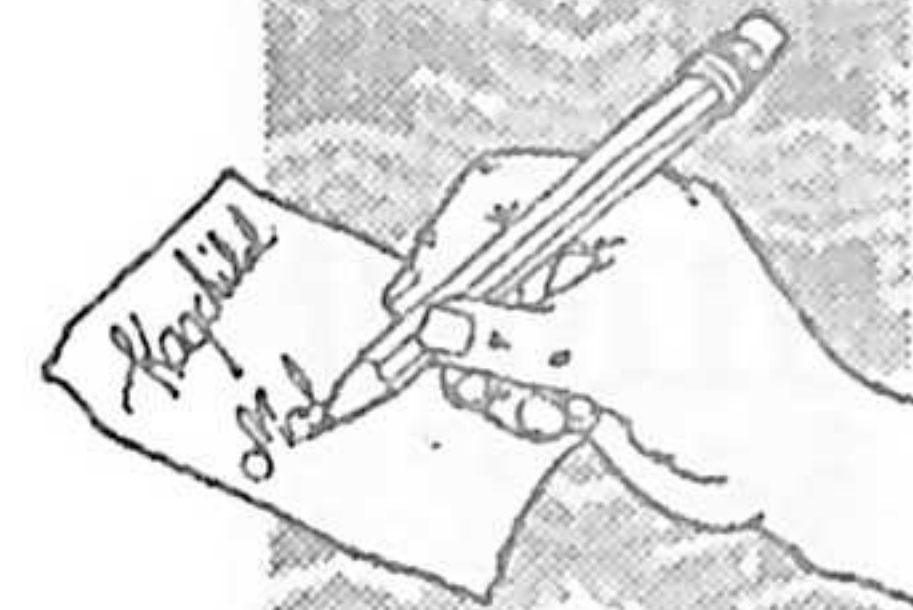

Ri tijoxela' yeq'ejelon achi'el nkib'an ri winaqi' chupam ri achib'al.

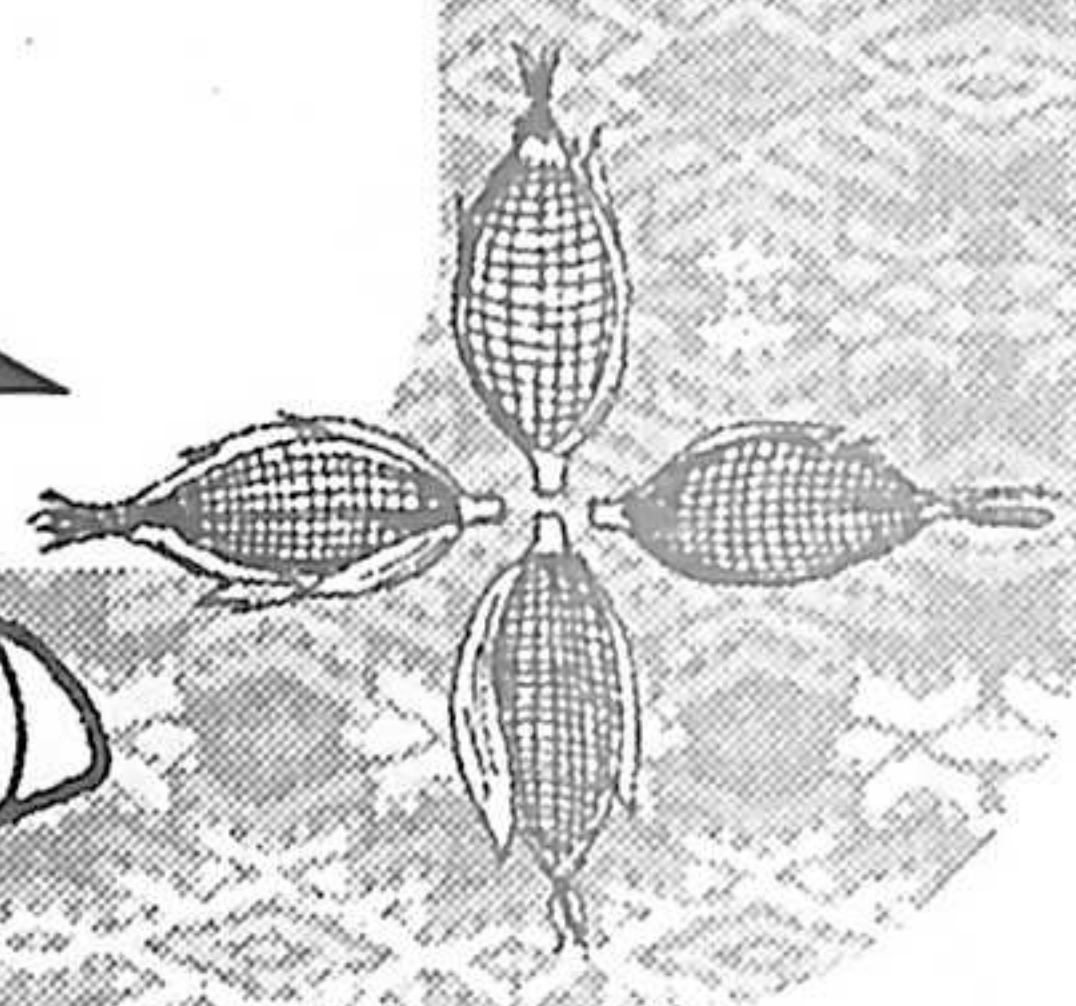

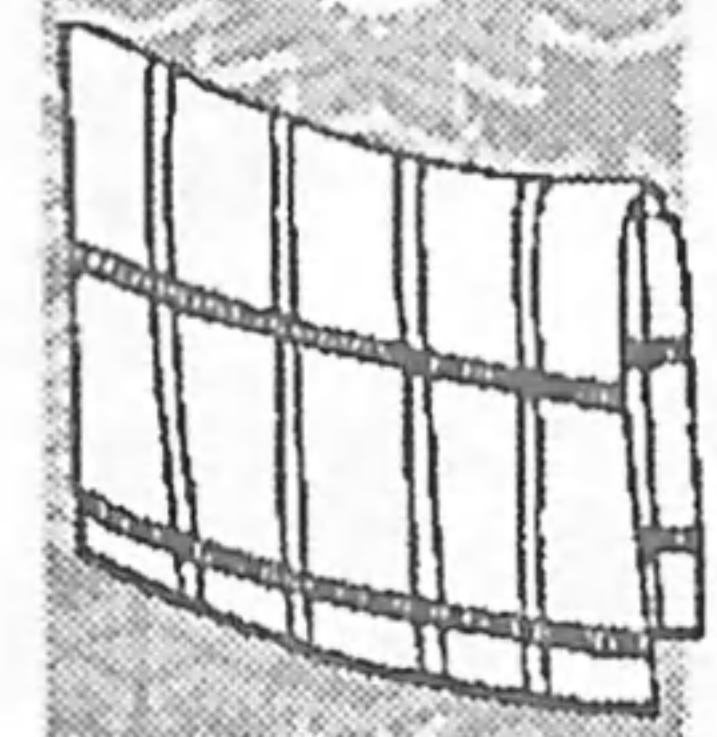
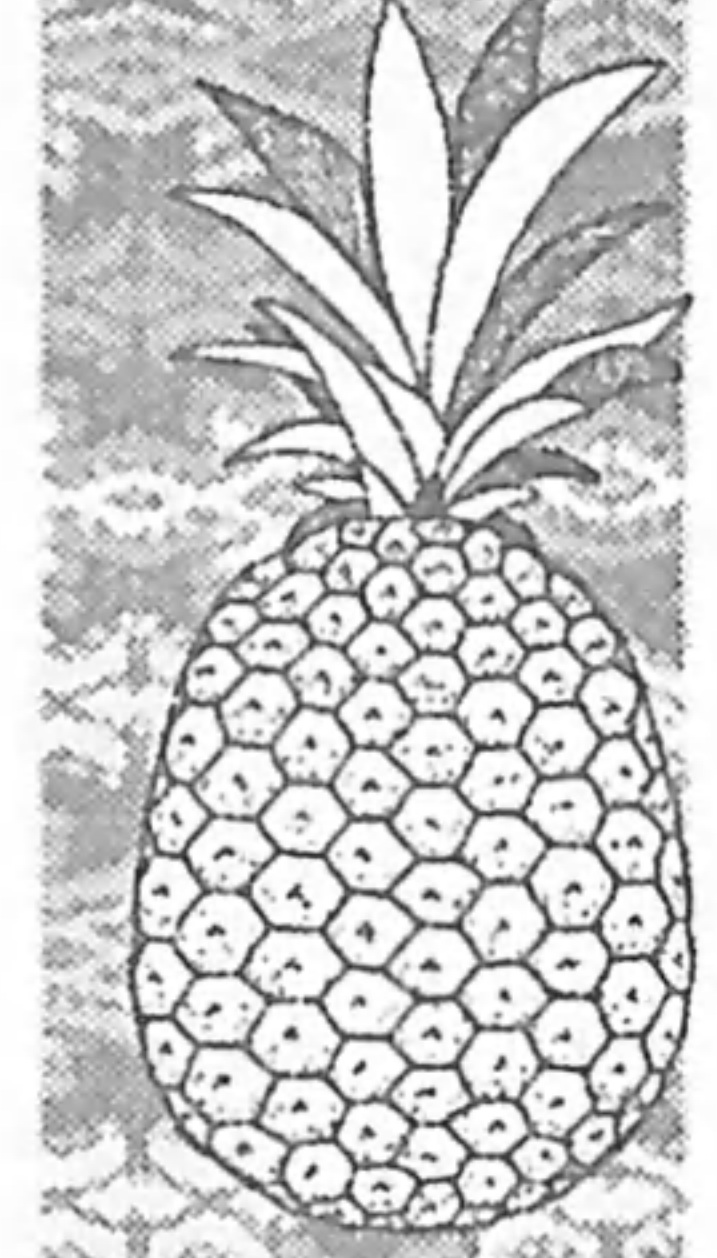

Sik'ajan: Ütz awäch Ma Pakal.  
 Pakal: Ütz matyox  
 Sik'ajan: Akuchi yatb'e wi wakami  
 Pakal: R'in yinb'e pa etz'anem.  
 Pakal: Rat akuchi yatb'e wi  
 Sik'ajan: R'in yinb'esamaj.  
 Pakal: Tachajij awi' k'a.  
 Sik'ajan: Matyox, chuqa' tachajij awi' rat.



Ixtuktuk: Xqaaq'ij Ixkotz'ij, ütz awäch.  
 Ixkotz'ij: Xqaaq'ij Ixtuktuk, ütz matyox.  
 Ixkotz'ij: ¿La ütz awäch rat?  
 Ixtuktuk: Ütz matyox.  
 Ixkotz'ij: Matyox k'a ri'  
 Ixtuktuk: Akuchi yatb'e wi.  
 Ixkotz'ij: R'in yinb'esamäj. Rat akuchi yatb'e wi.  
 Ixtuktuk: R'in yinb'enatin.  
 Ixkotz'ij: Tachajij awi' k'a.  
 Ixtuktuk: Matyox, chuqa' tachajij awi' rat.

Kojtzijon

Ala'



Q'opoj

Rin Rat Rija' Röj Rije' Rix

1 Ri tijonel nutzijoj chi kiwäch ri tijoxela' ri q'ejelonik nkib'an ri k'ajola' chuqa' ri q'opoji', k'a ri' nkikamuluj ri tijoxela'.

# Tqatzu' chuqa' Tqak'axaj

Saqche': Ütz awäch Aq'ab'al  
 Aq'ab'al: Ütz matyox.  
 Saqche': Akuchi yatb'e wi wakami  
 Aq'ab'al: Rïn yinb'esamäj  
 Saqche': Tachajij awi' k'a  
 Aq'ab'al: Matyox. Chuqa' tachajij awi' rat



Ixmukane: Xsaqër Ixchel, ütz awäch.  
 Ixchel: Ütz matyox.  
 Ixmukane: Akuchi yatb'e wi  
 Ixchel: Rïn yinb'esamäj. Rat akuchi yatb'e wi.  
 Ixmukane: Chuqa' rïn yinb'esamäj.  
 Ixtz'unün: Ütz awäch Lolmay

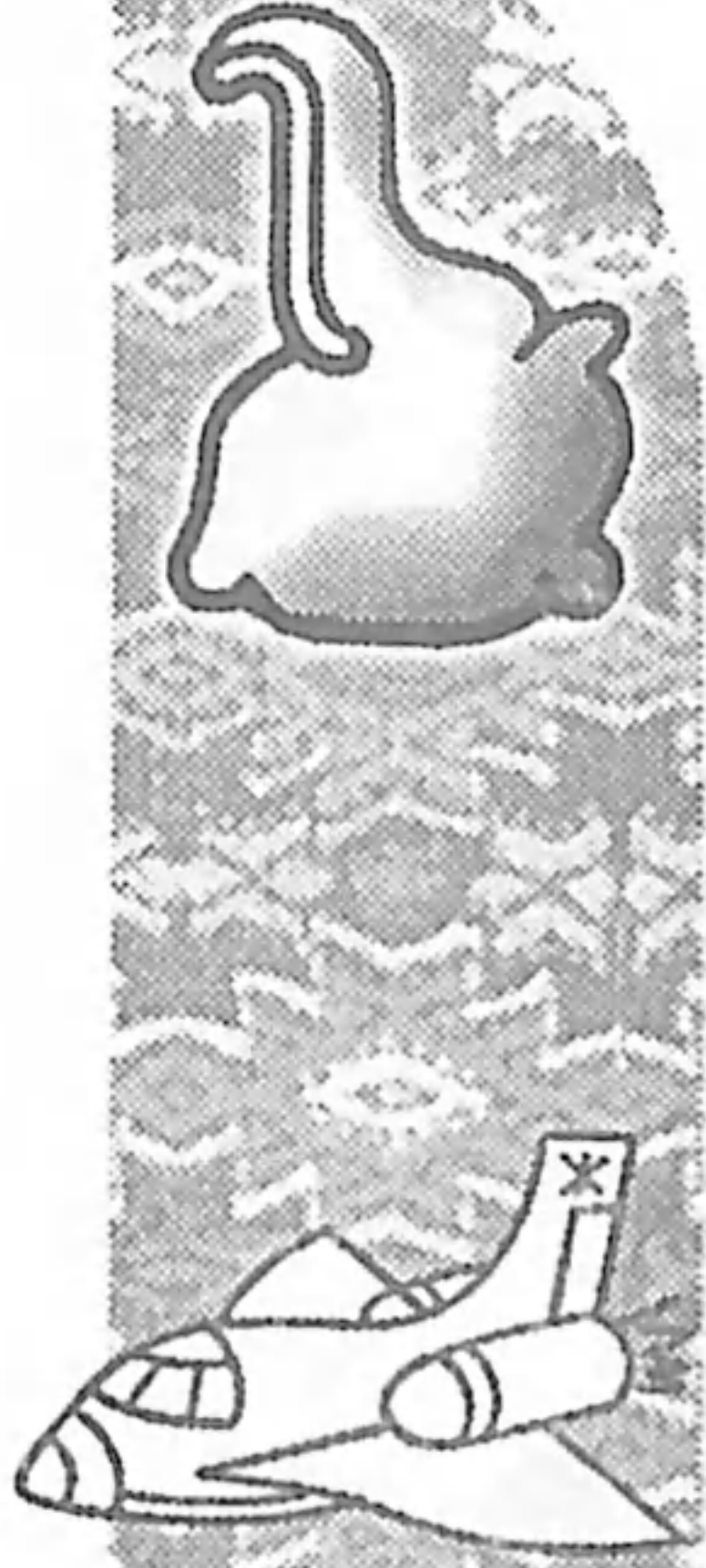

Lolmay: Ütz matyox.  
 Ixtz'unün: Akuchi yatsamäj wakami  
 Lolmay: Rïn yinsamäj pa tijob'äl. Rat akuchi yatsamäj.  
 Ixtz'unün: Rïn yinsamaj pa nimatijob'äl.

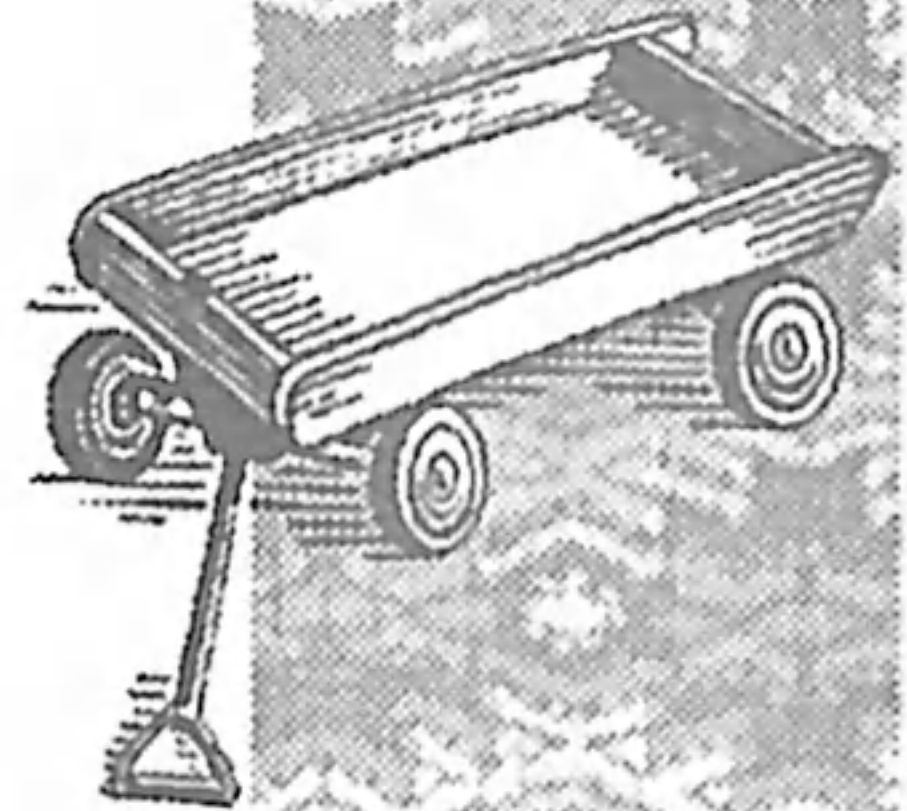
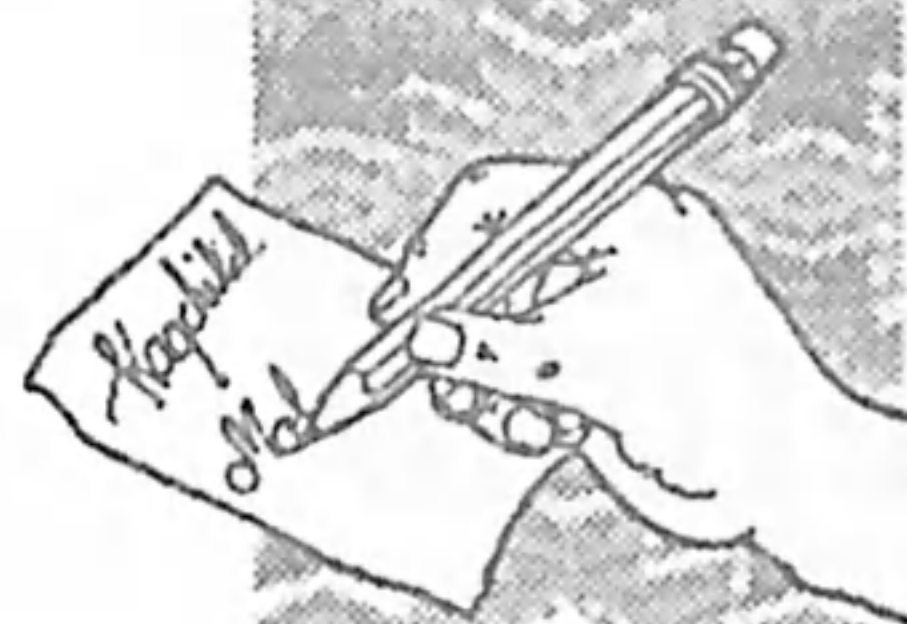

1 Ri tijonel nutzijoj chi kiwäch ri tijoxela' ri q'ejelonik nkib'än chi kikojoj ri nima'q taq winaqi' chuqa' ri e tijonela'.

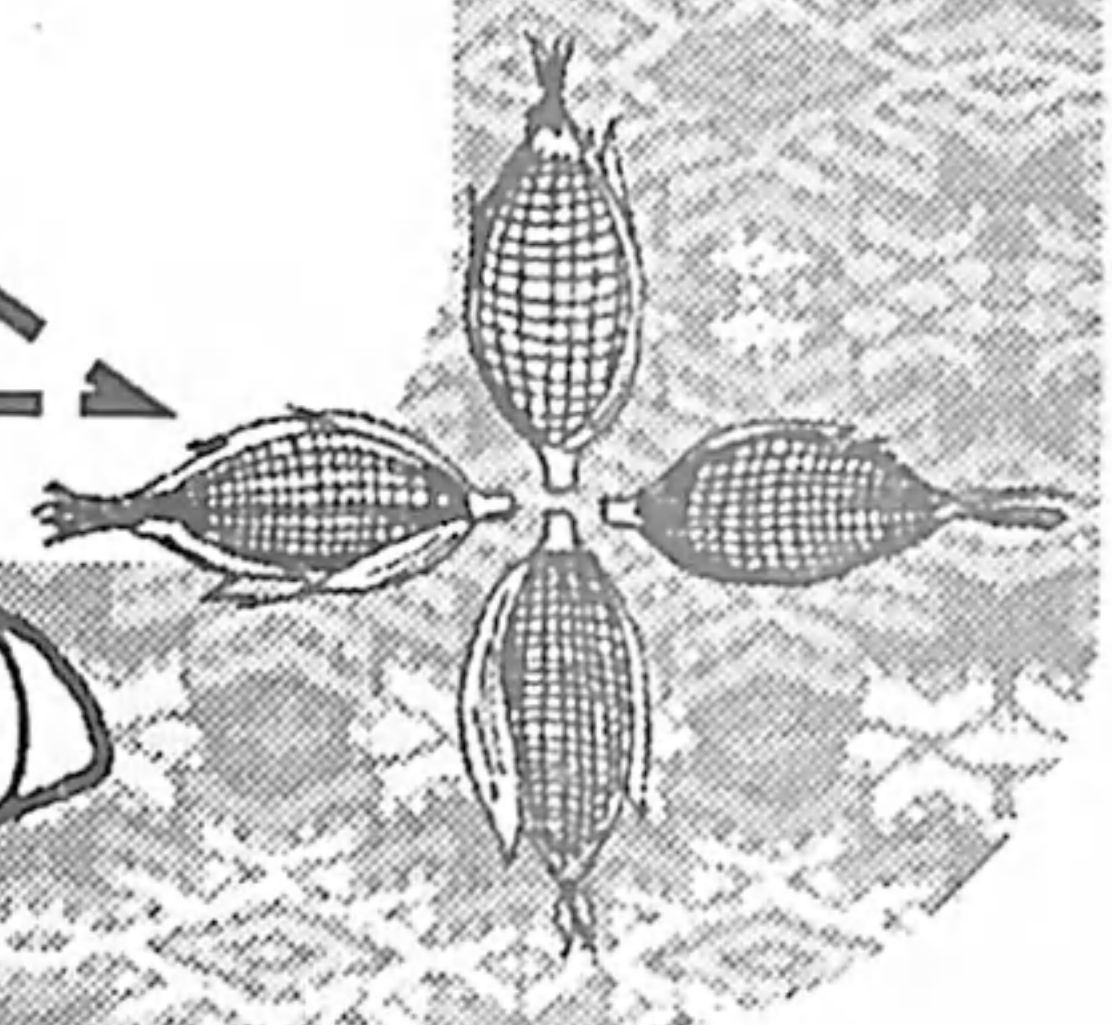

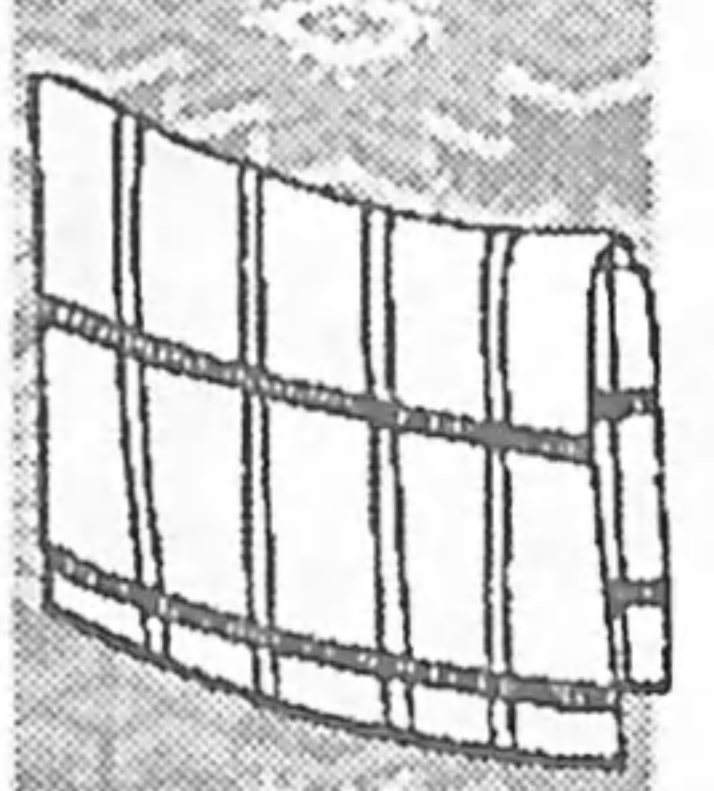
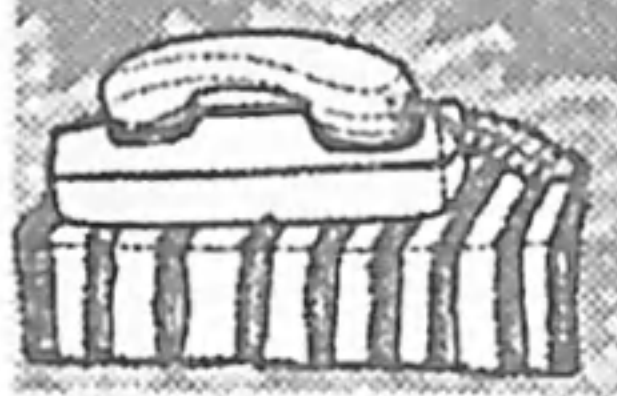
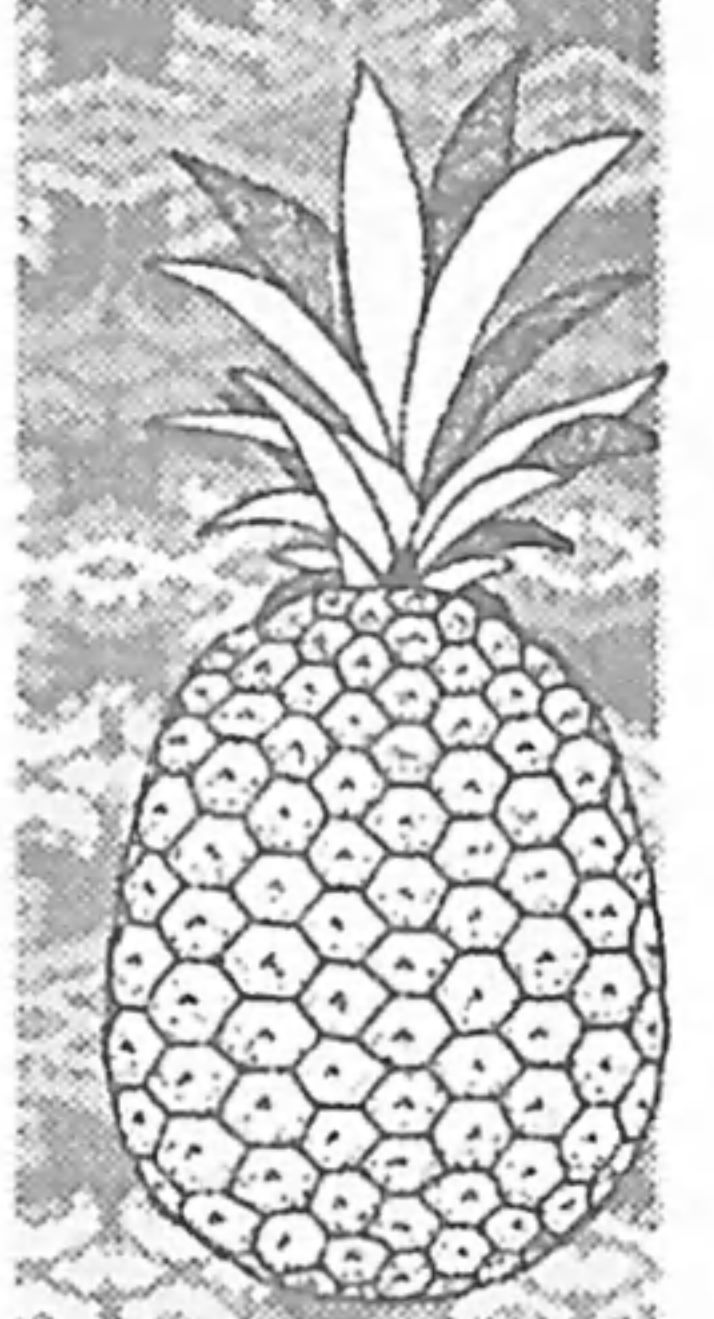
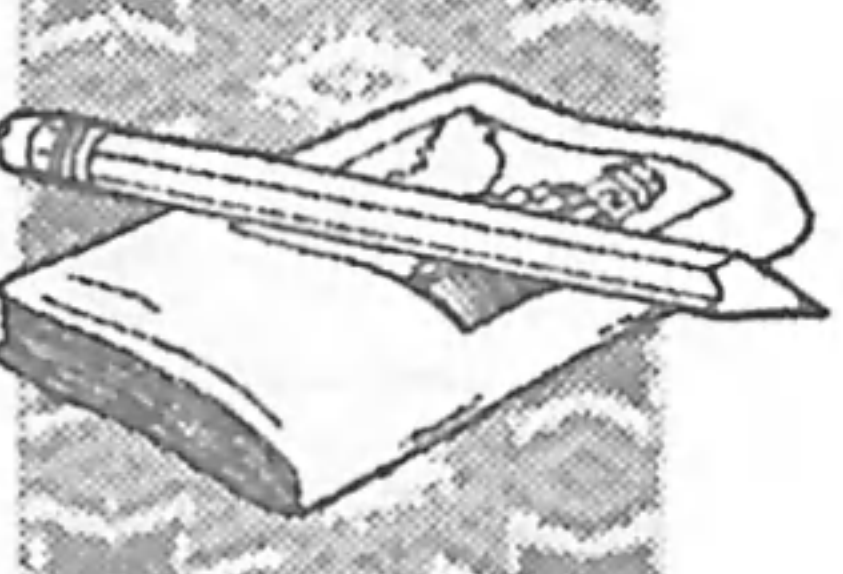

Achin

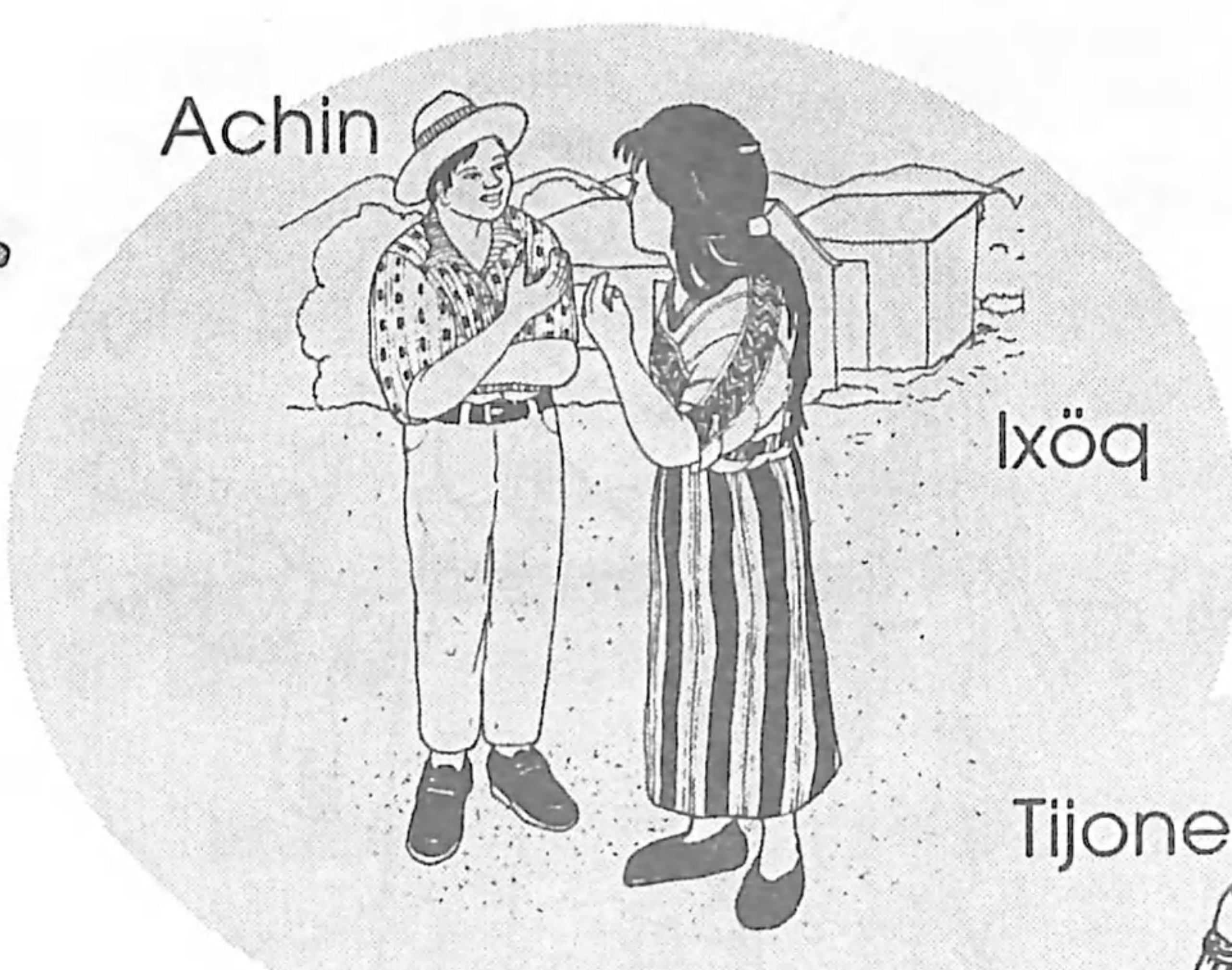

Ixöq

Nimatijob'äl

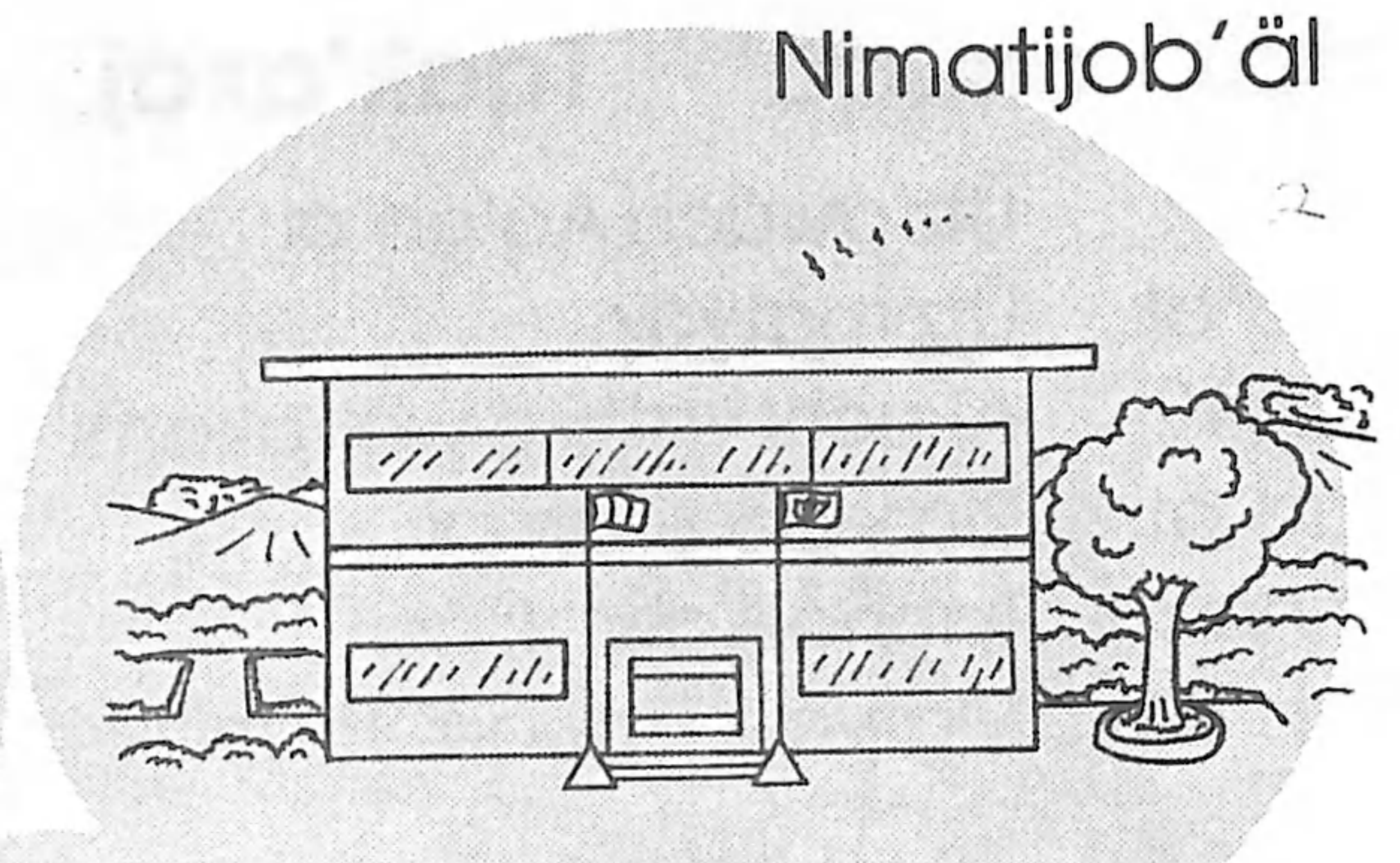

Tijonel



Tijoxel

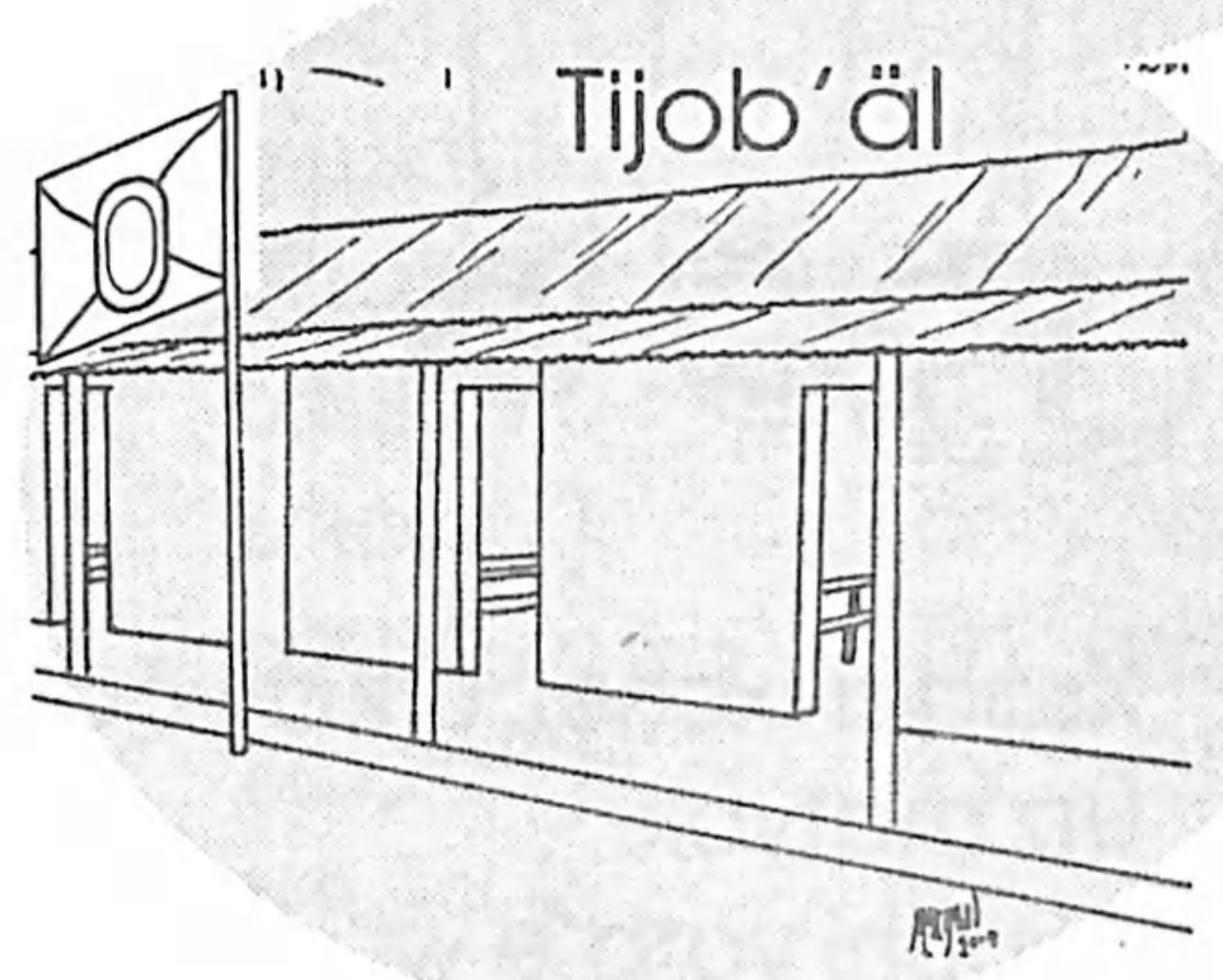

Kojtzijon rik'in jun qachib'il, tqab'ana' jun ka'i' oxi' k'utunik chi re, k'a ri' tqatz'aqatisaj ri tzij pa ruwi' ri jux.

Ma Lu': ¿Akuchi yatb'e wi rat?

Ma Tich'ok: R'in yinb'e \_\_\_\_\_

Ma Lu': ¿Akuchi yatsamaj wi?

Ma Tich'ok: R'in yinsamaj pa \_\_\_\_\_

Ma Lu': ¿Achike ri asamaj rat?

Ma Tich'ok: Ri nusamaj \_\_\_\_\_

1 Ri tijonel nuq'alajirisaj chi kiwäch ri tijoxela' ri jalajöj taq achib'äl, k'a ri' yekib'än jun ka'i' oxi' k'utunik chi ke ri kachb'il, richin yekitz'aqatisaj ri tzij.

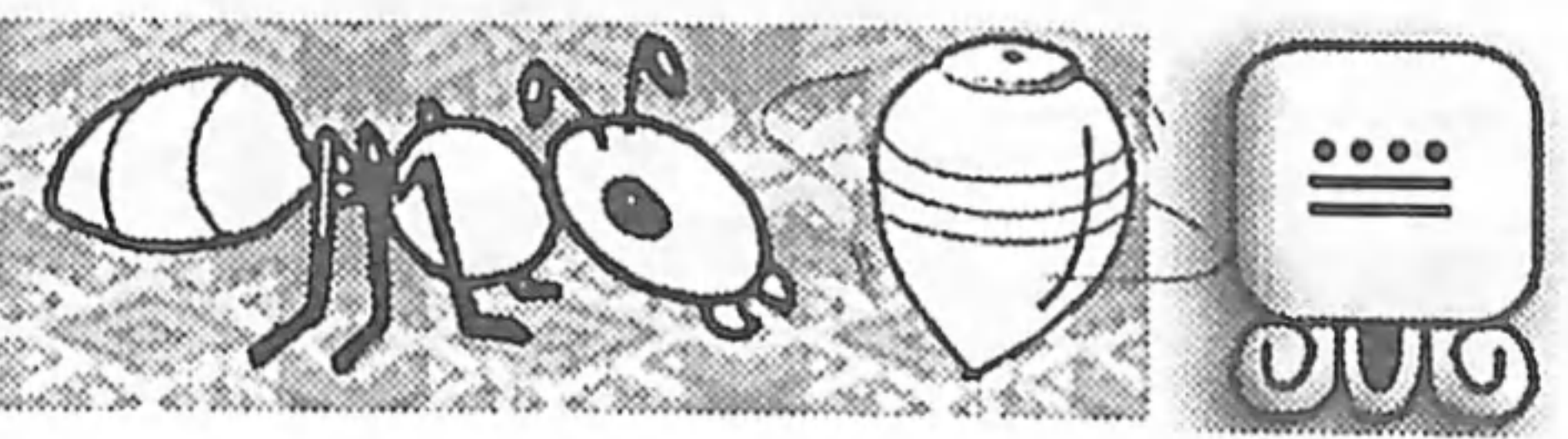

# Tqatzu' chuqa' tqak'axaj

Tat Raxche': Ütz awäch tat.  
 Tat Xwan: Ütz matyox tat.  
 Tat Raxche': Rat ütz awäch tat.  
 Tat Xwan: Ütz matyox.  
 Tat Xwan: Matyox k'a ri'.  
 Tat Raxche': Achike rub'anon ri nan.  
 Tat Xwan: Rija' ütz ruwäch matyox.  
 Tat Raxche': Matyox k'a ri', nqatz'ët qi' k'a.  
 Tat Juan: Ja'e matyox.

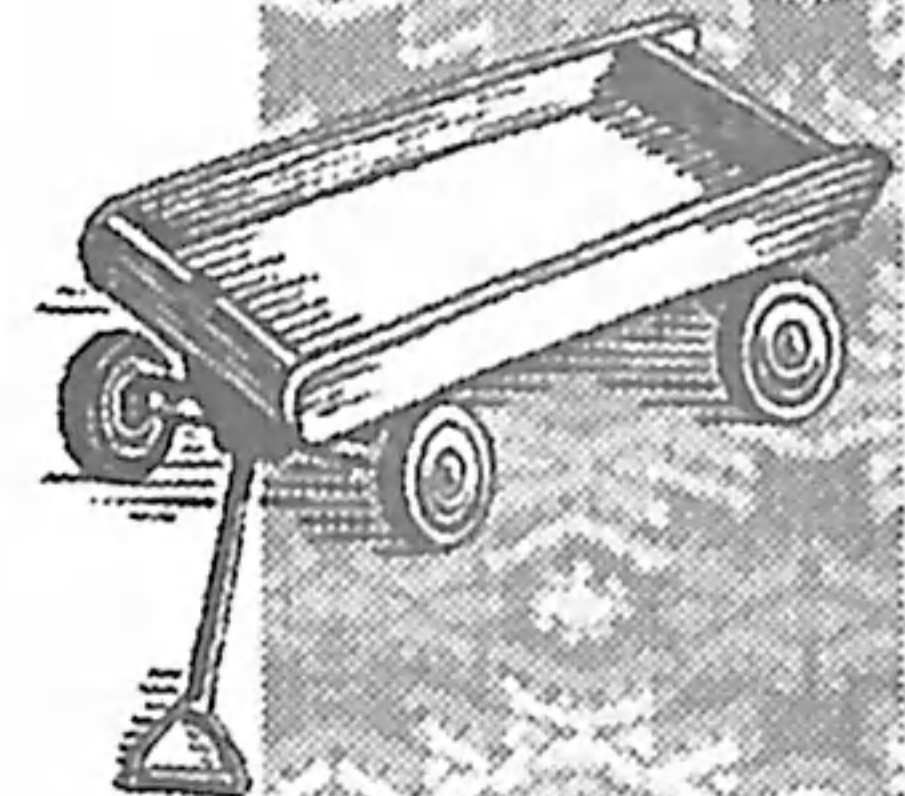
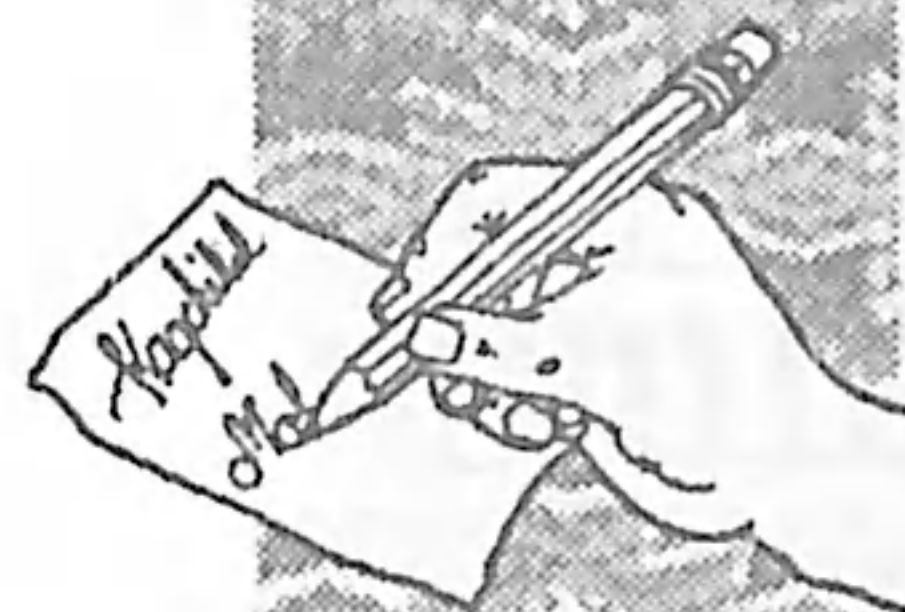
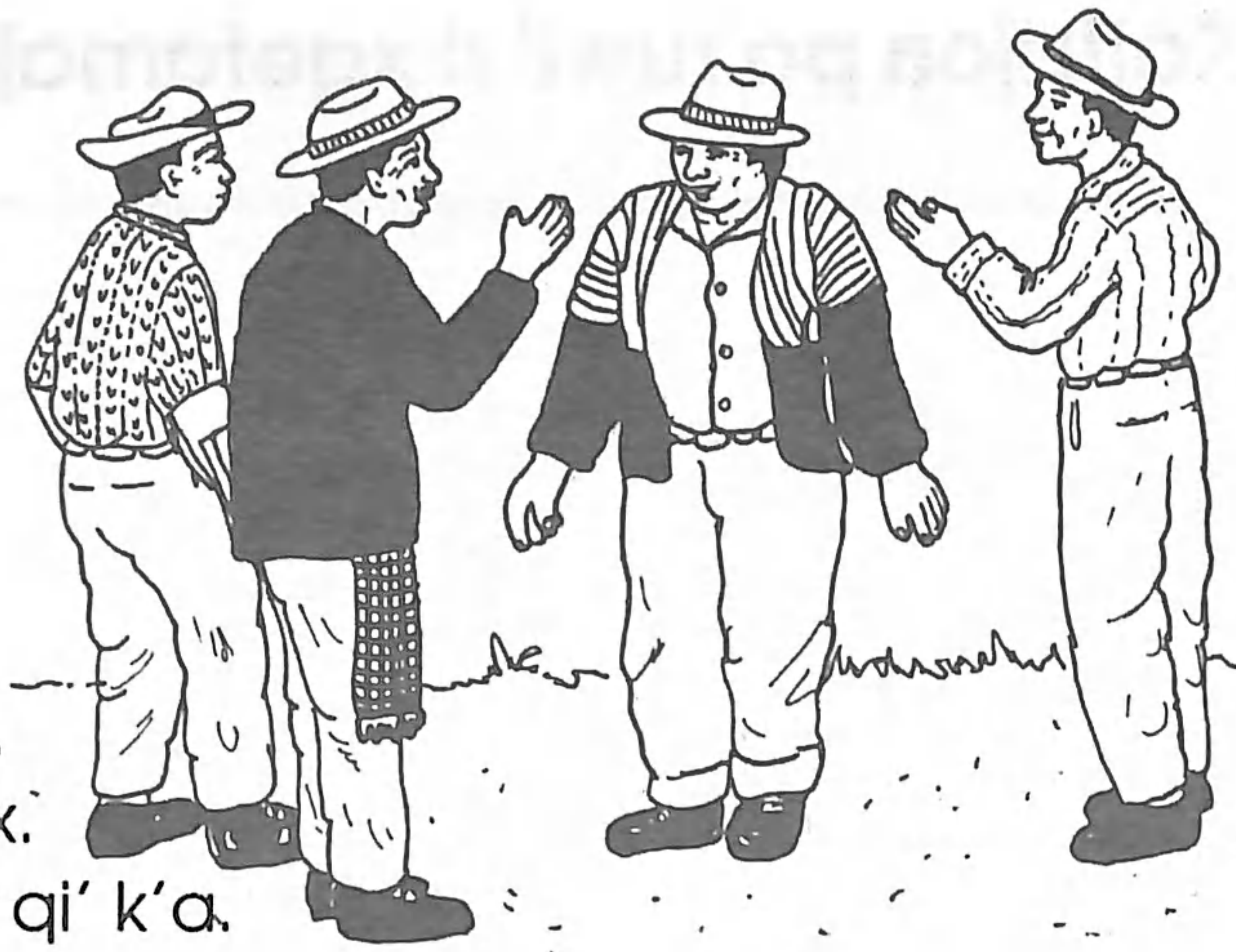

Rub'eyal yeq'ejelon ri winaqi' e tetata' chik.



Ixtz'ulu':  
 Ixsu'm:

Nan



Tat

1 Ri tijonel nutzijoj chi kiwäch ri tijoxela' ri rub'eyal yeq'ejelon ri e tetata' chik,

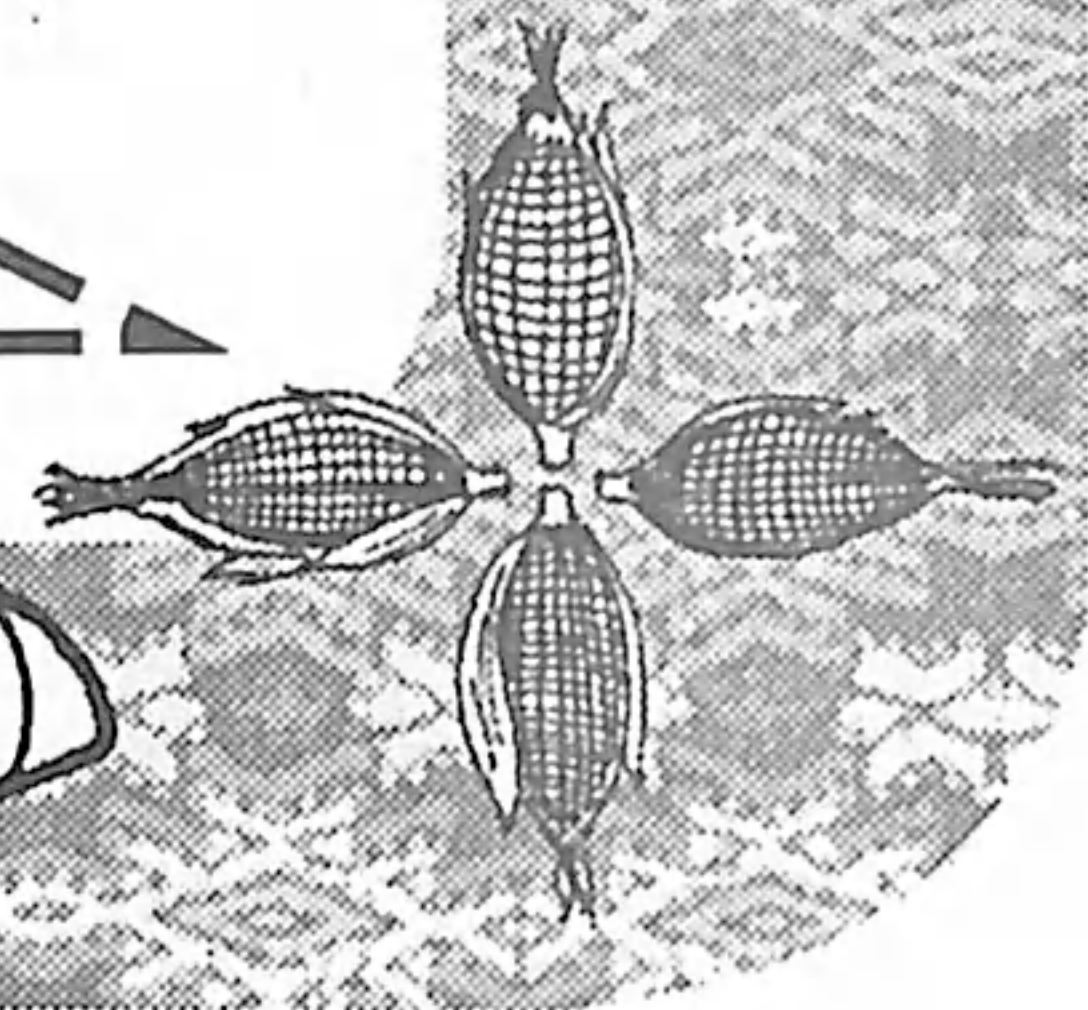
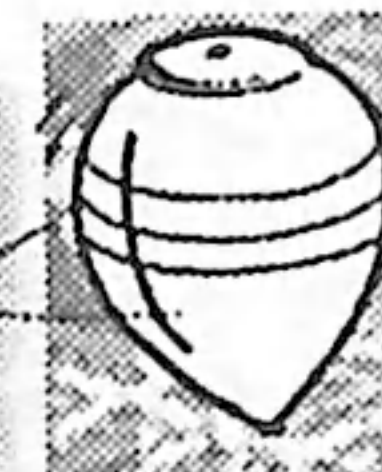



# Kojtzijon pa ruwi' ri xqetamaj



Ri Xinwetamaj

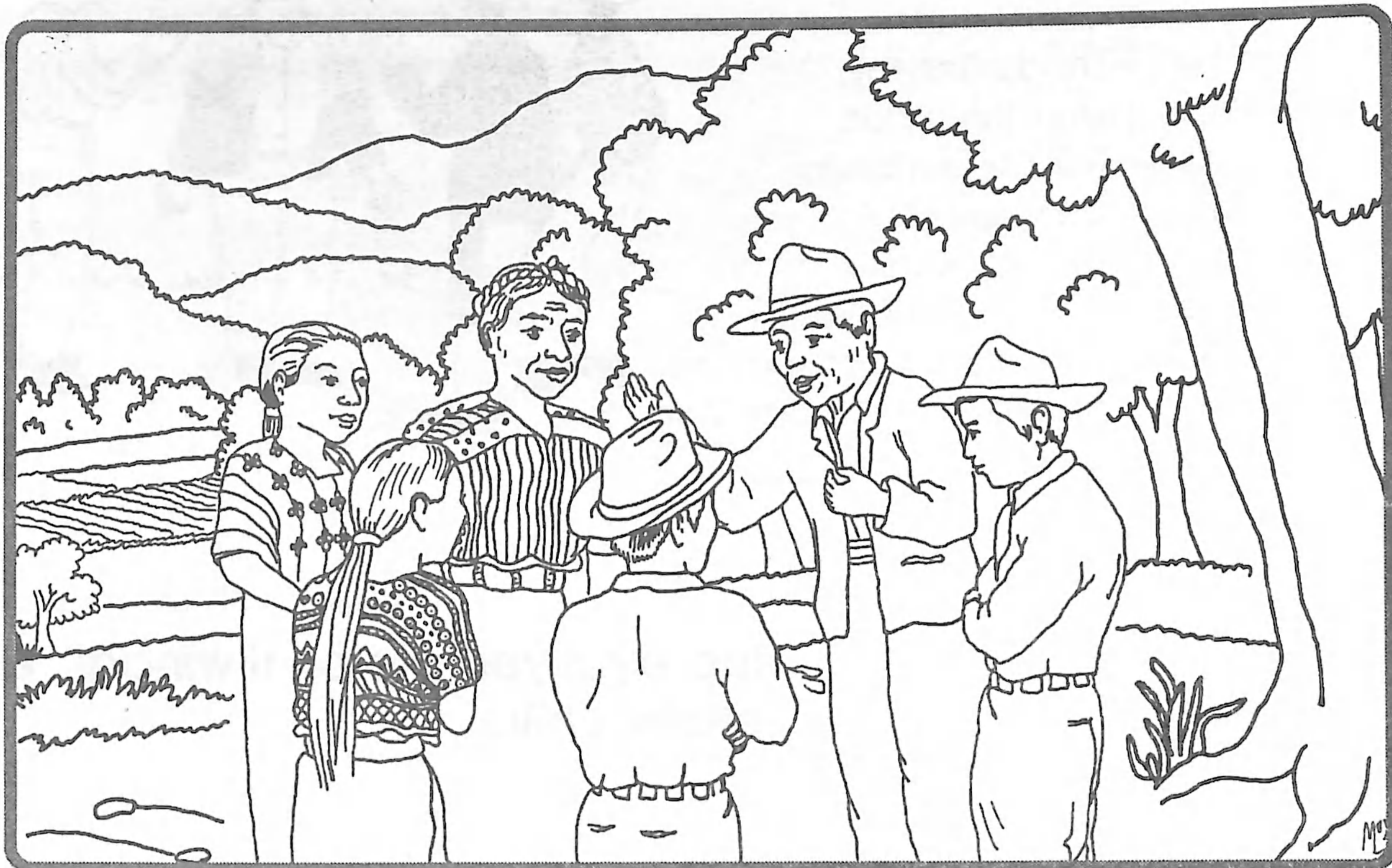

Ixtän: xqaa'ij tat  
 Tat: xqaa'ij noya. Ütz kiwäch ri ate' atata'.  
 Ixtän: Ja' ütz kiwäch tat. Rät ütz awäch tat.  
 Tat: R'in ütz nuwäch matyox. Ri achaaq' ütz kiwäch.  
 Ixtän: Ja', ri nuchaaq' ütz kiwäch matyox.  
 Tat: Tachajij awi' noya'. Ja'e' matyox tat.

Ak'wal: Xoqa \_\_\_\_\_

Nan: \_\_\_\_\_

1 Ri tijoxela' k'atzinel nketamaj ri q'ejelonik nkib'än chi kikojol jun tetata' rik'in jun q'opoj. Chuqa' k'atzinel nkikamuluj achike xketamaj pa ruwi' ri q'ejelonik.



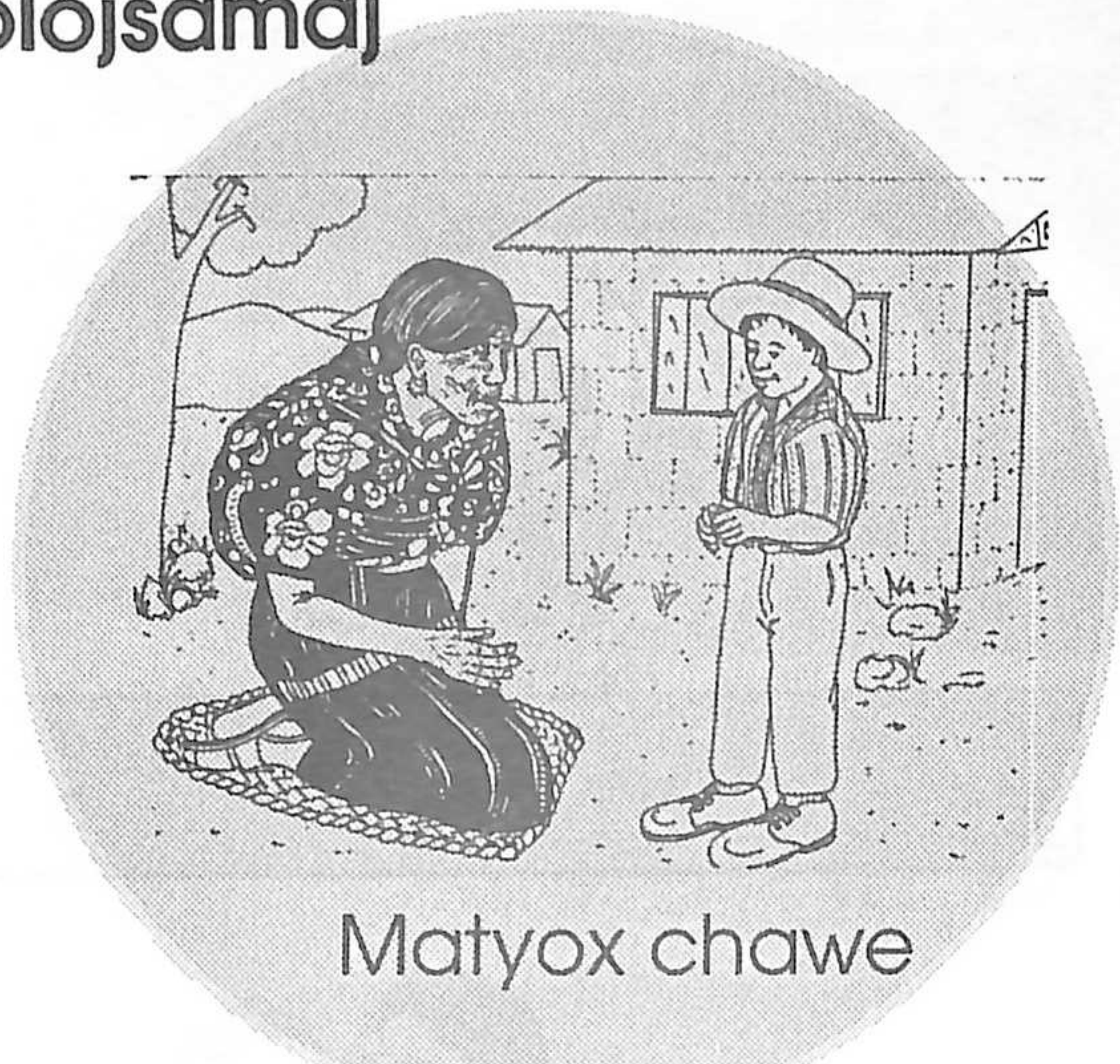

Matyox chawe



Yiq'ax jub'a awikin



Chwa'q chik



Tab'ana' utzil



Tachajij awi' k'a



Yatinto' jub'a

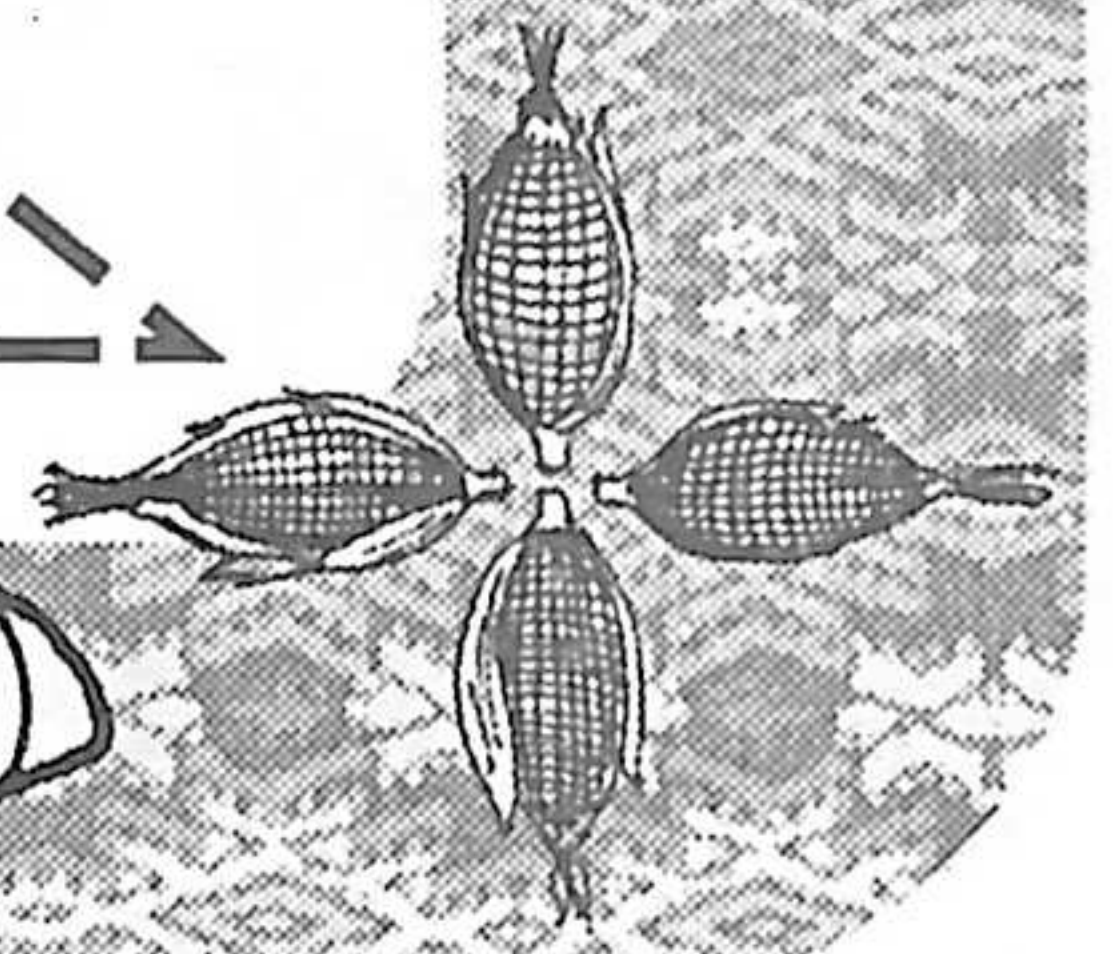
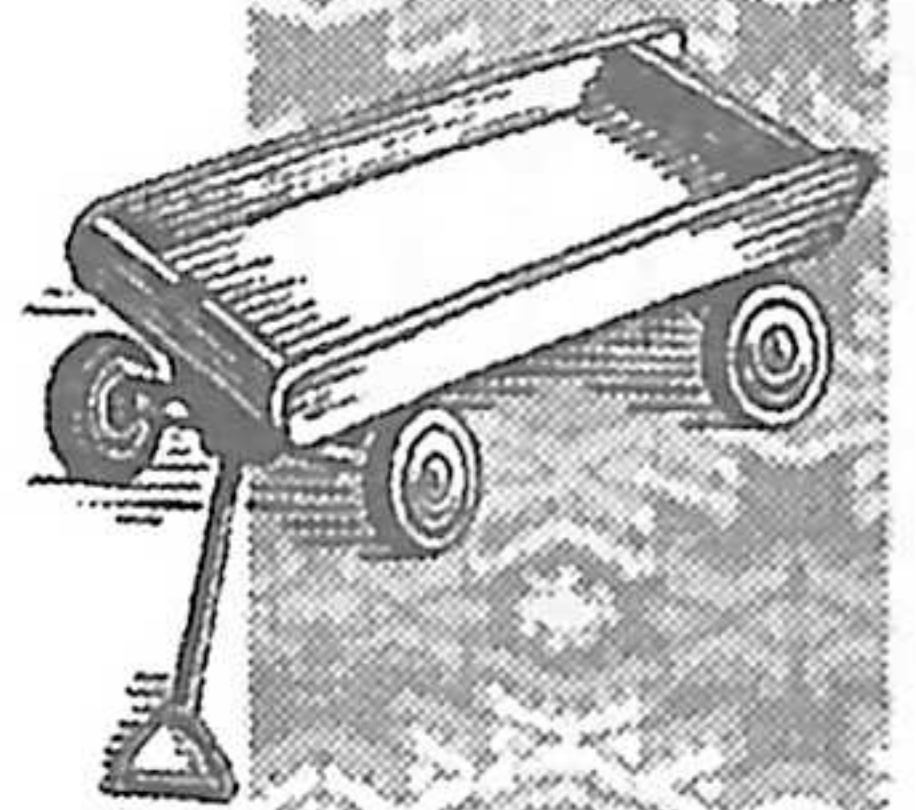
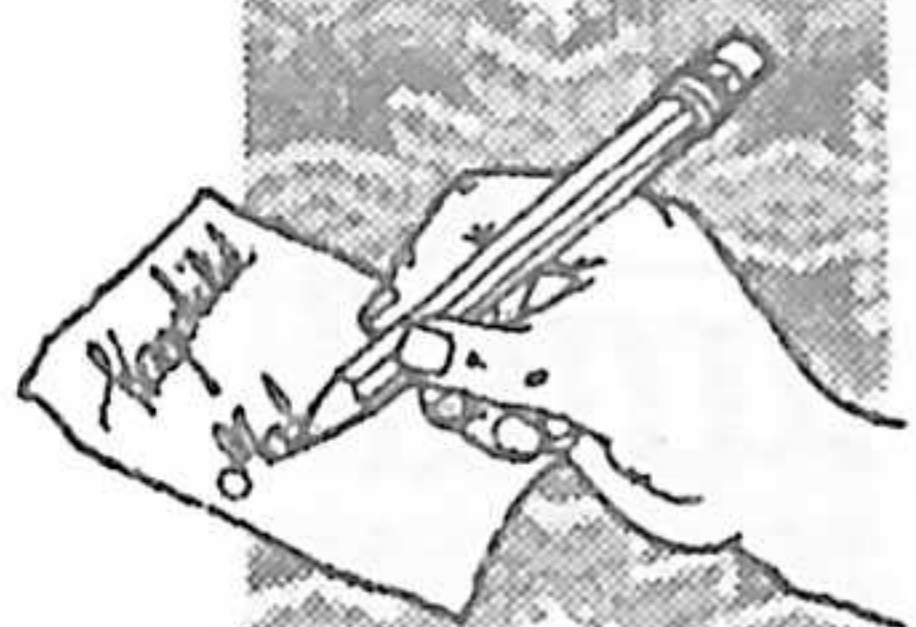

Ri tijonel k'atzinel yeruto' ri tijoxela' richin nkib'an re jun samaj re', akuchi ri tijoxela' k'o chi yetzjon chi kiwäch.

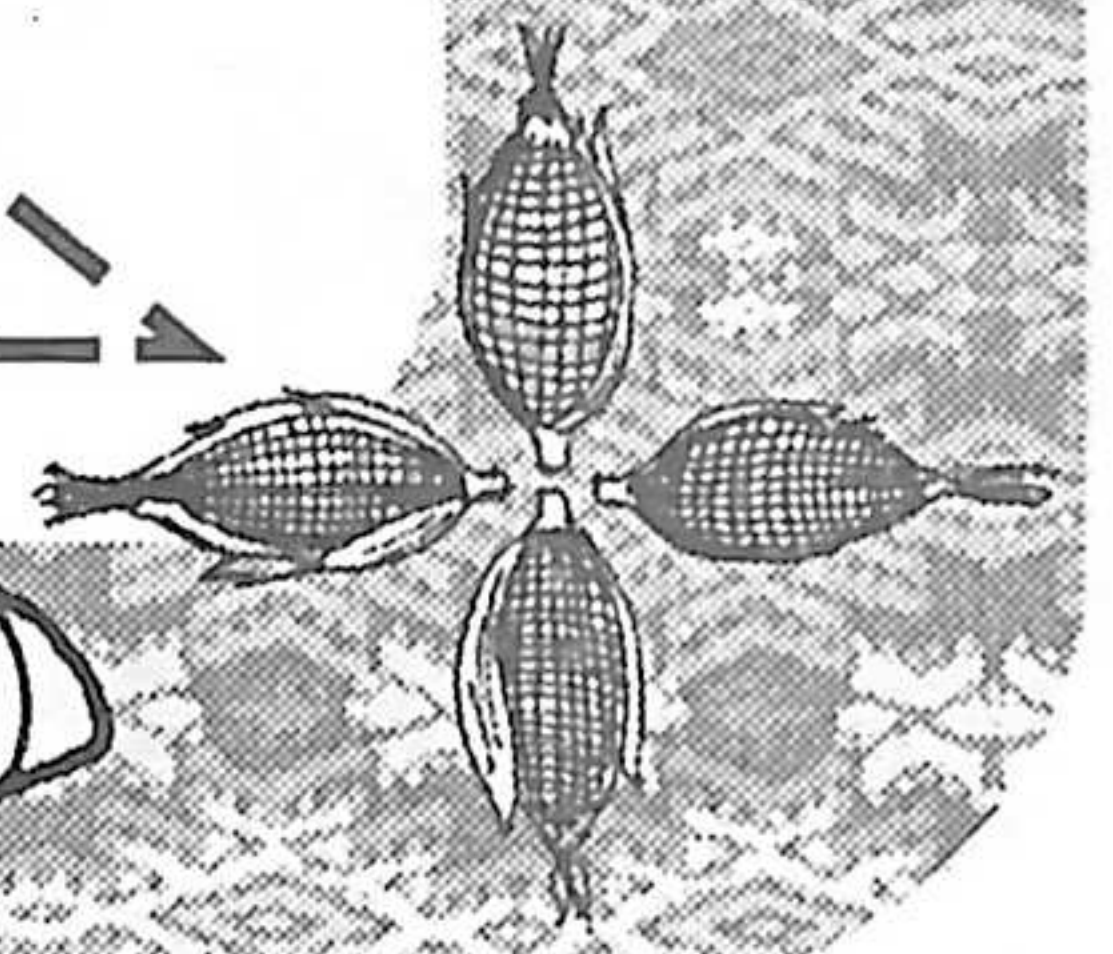
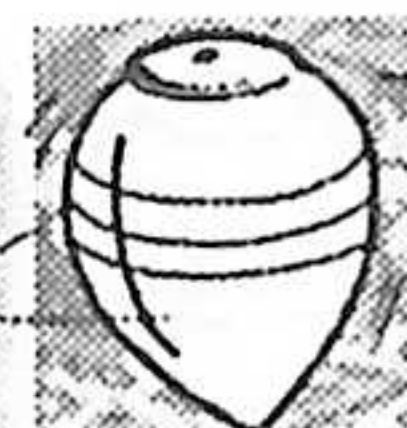
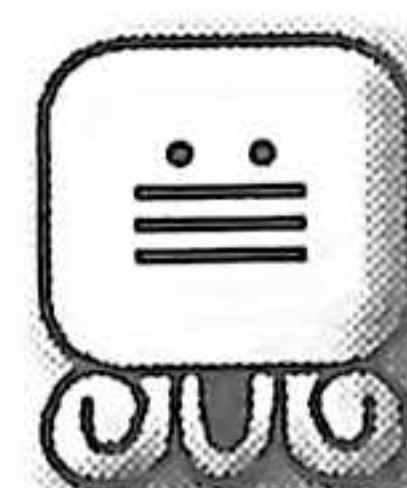

# Tojtob'enik



Ri Xinwetamaj

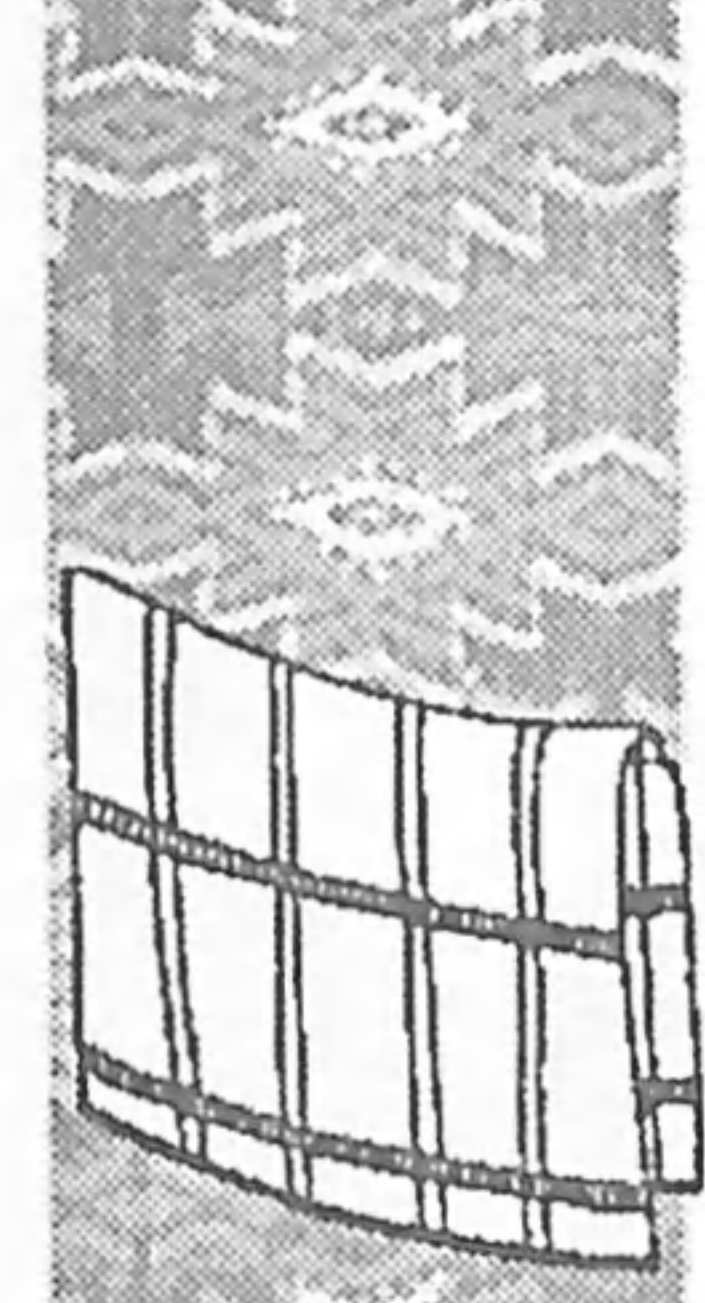
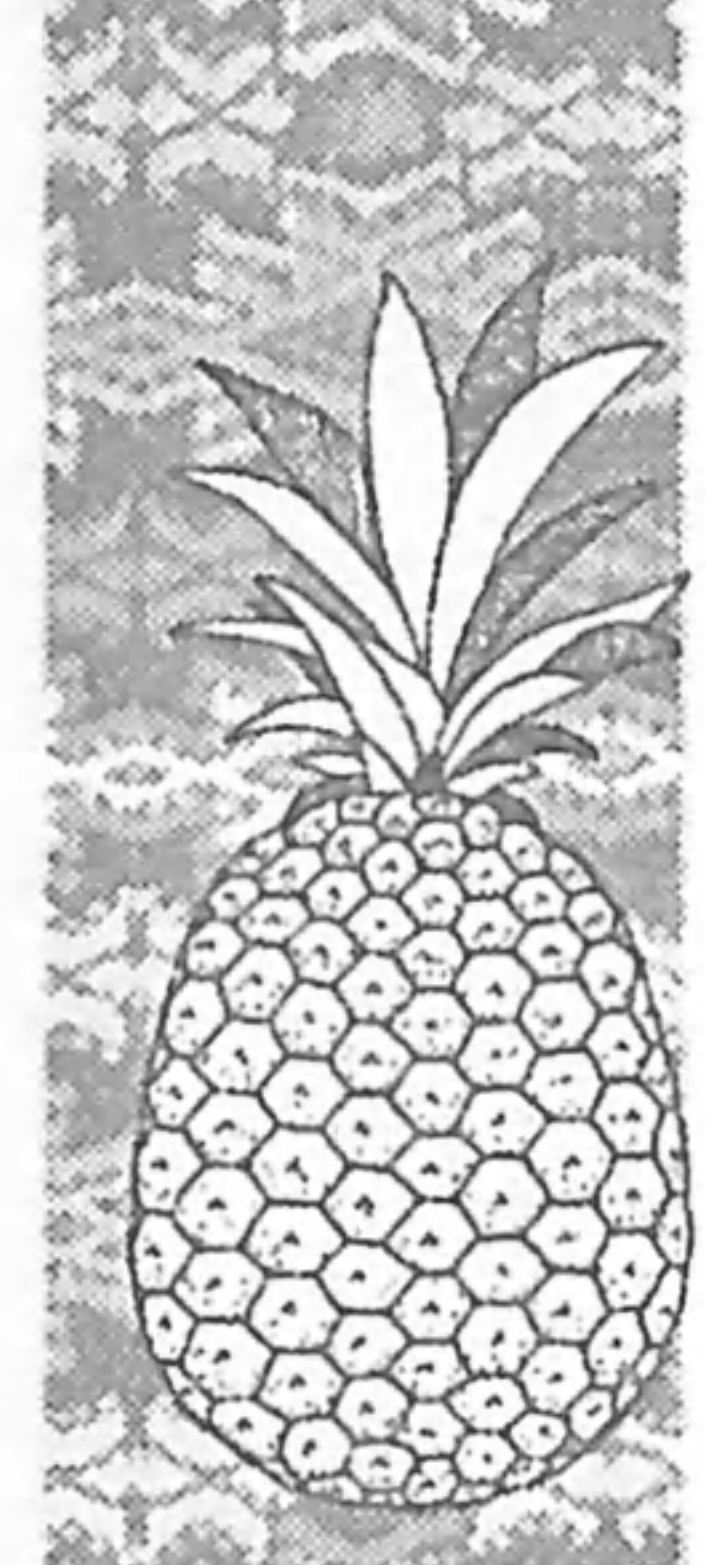

1. Ri tijonel k'atzinel yeruto' ri tijoxela' richin nkitz'ib'aj kib'i' ri jalajöj taq achib'äl.



# RUKA'N TANAJ

## Ri Qochoch

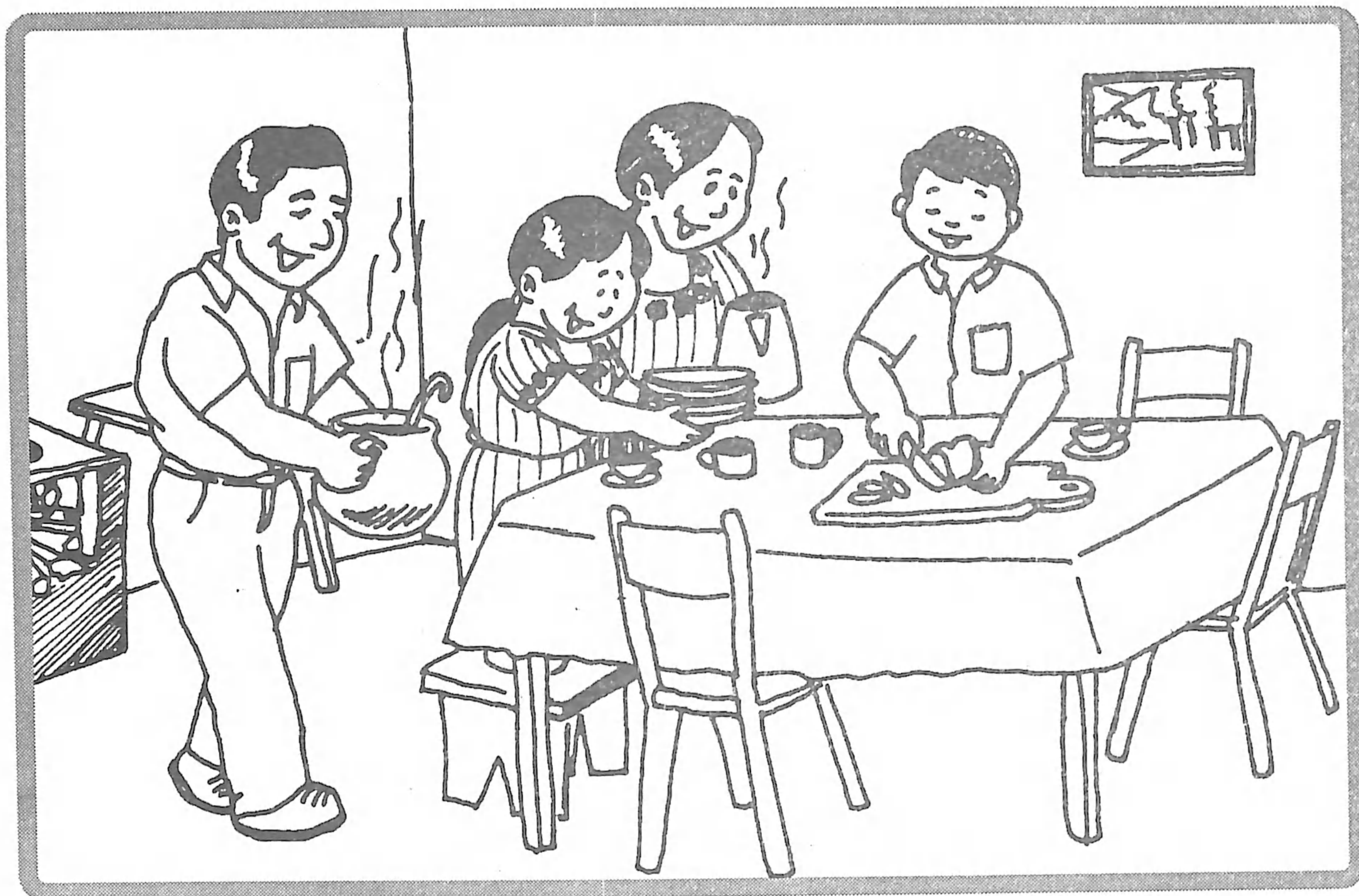

Ri etamanik nuq'i' ri tijoxel:

Nuch'ob' rejqalem ri rochoch.  
Nuch'ob' janipe' jay e k'o pa rochoch.  
Nuch'ob' ri rik'a'tz jun jay.

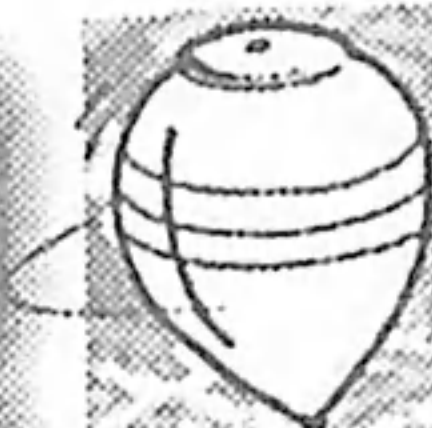
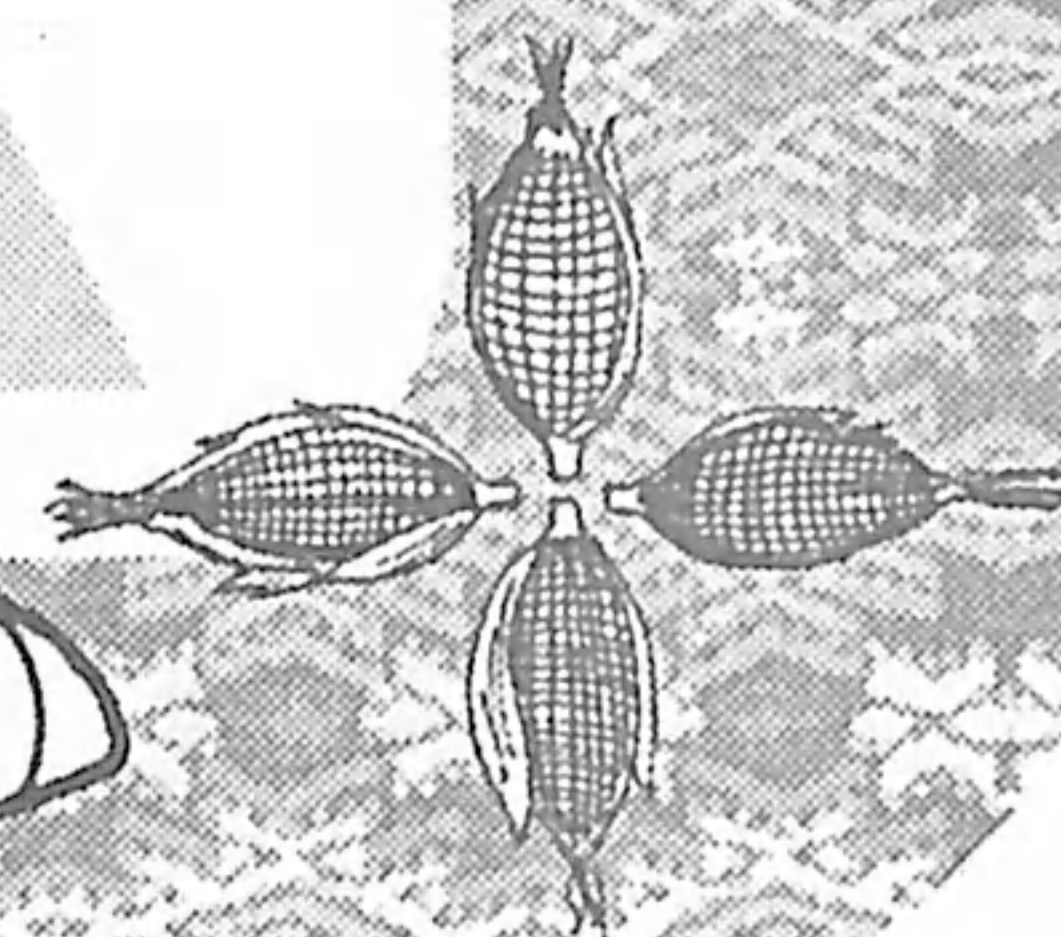
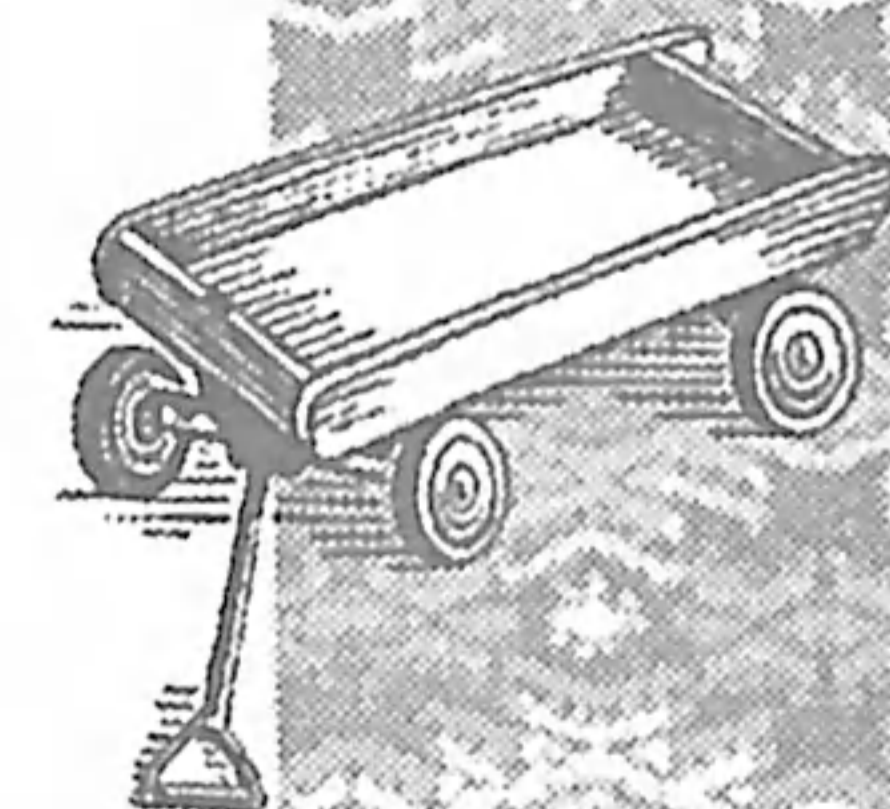
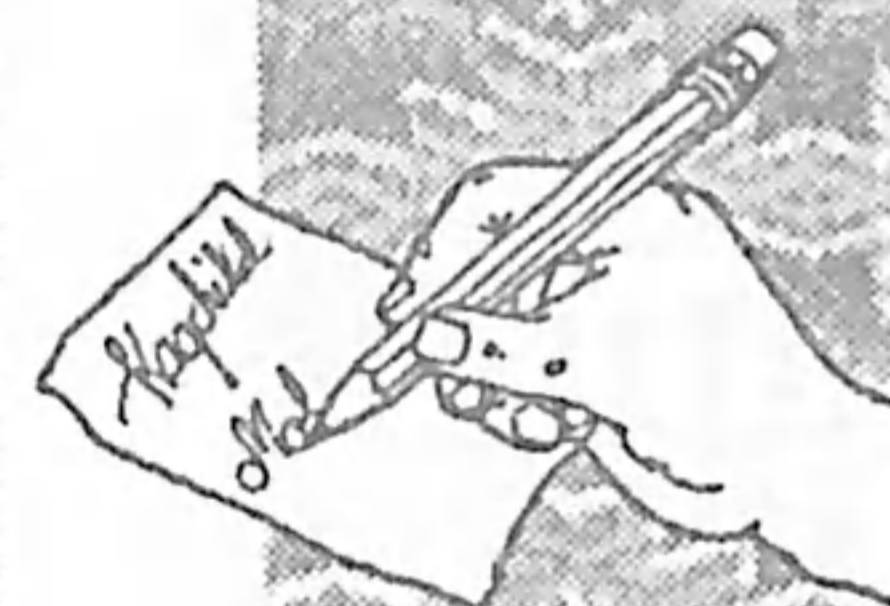



Chupam re jun ruxaq wuj re' nqab'än rachib'äl ri qochoch, k'a ri' nqatz'ib'aj ri ruch'arik rub'anon.

Ri Wetaman

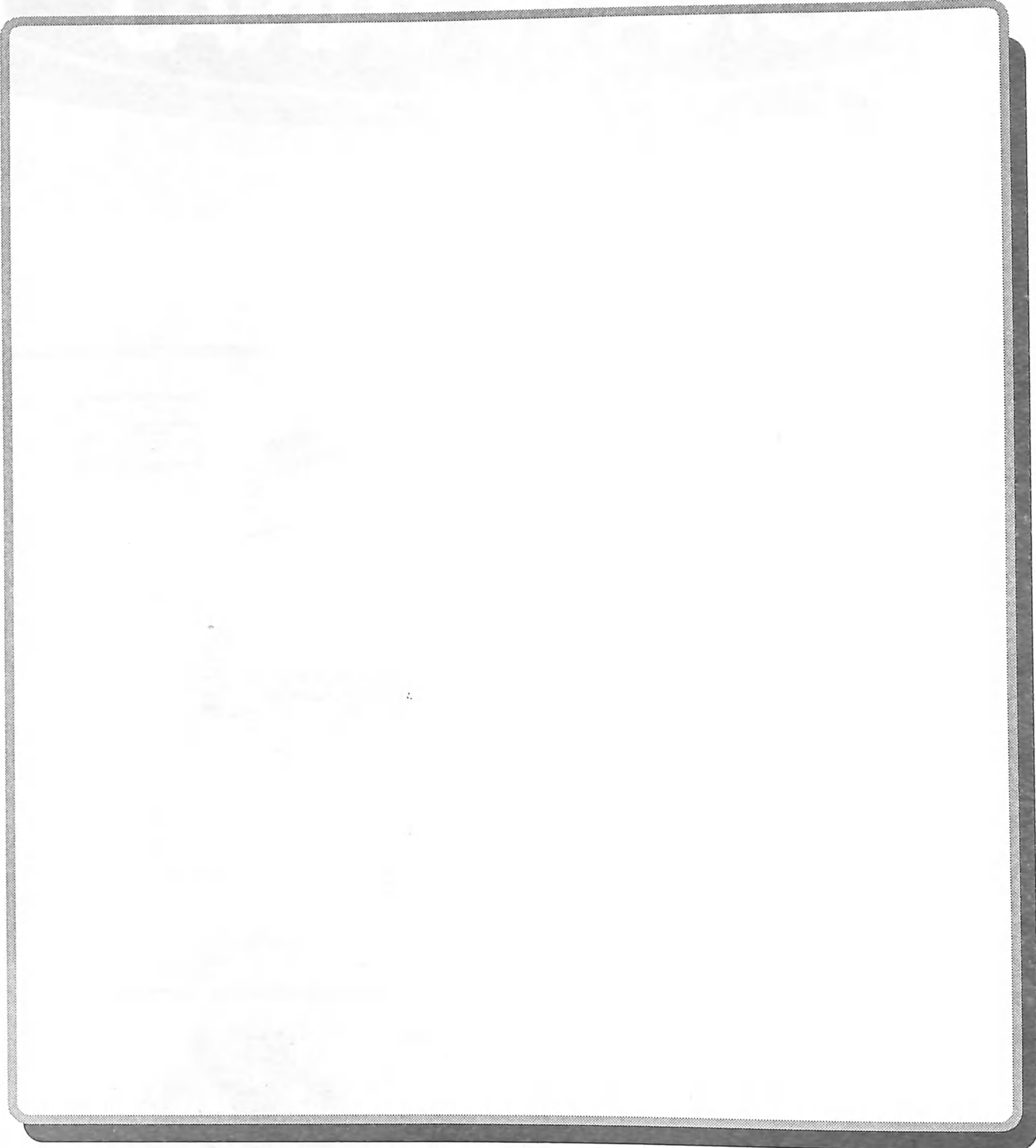
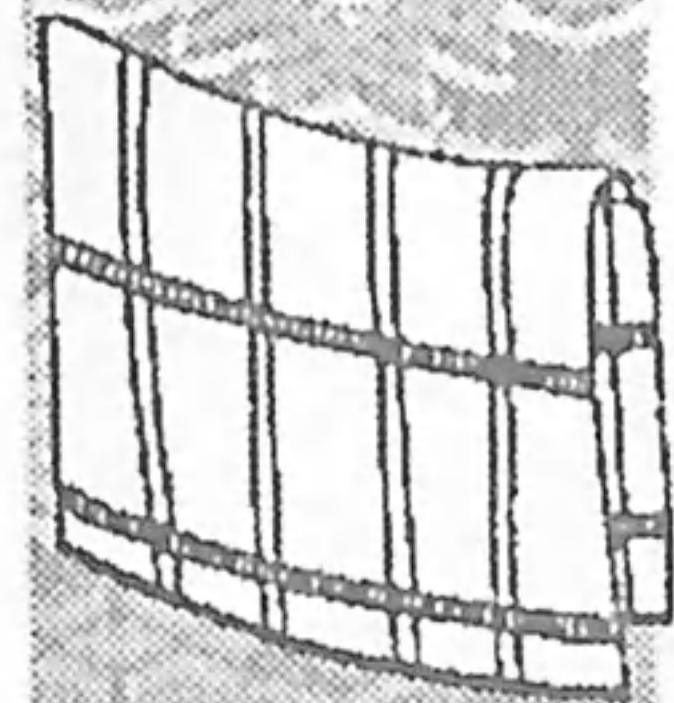
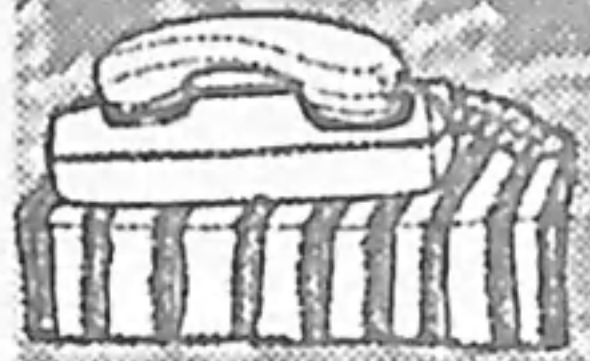

Ri tijonel keruto' ri tijoxela' richin nkib'än rachib'äl ri kochoch , töq yek'achoj keruto' richin nuya' kib'i'. Re samaj re' tikirel nkib'än pa taq molaj.

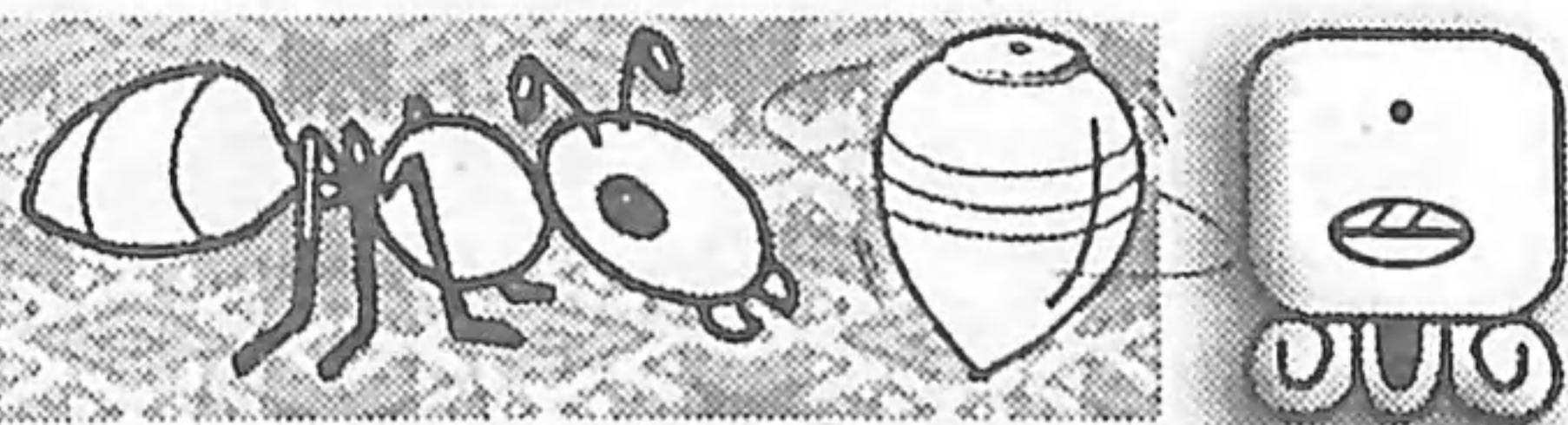

Rejqalem ri qochoch pa qak'aslem  
 Ri qochoch nk'atzin richin.

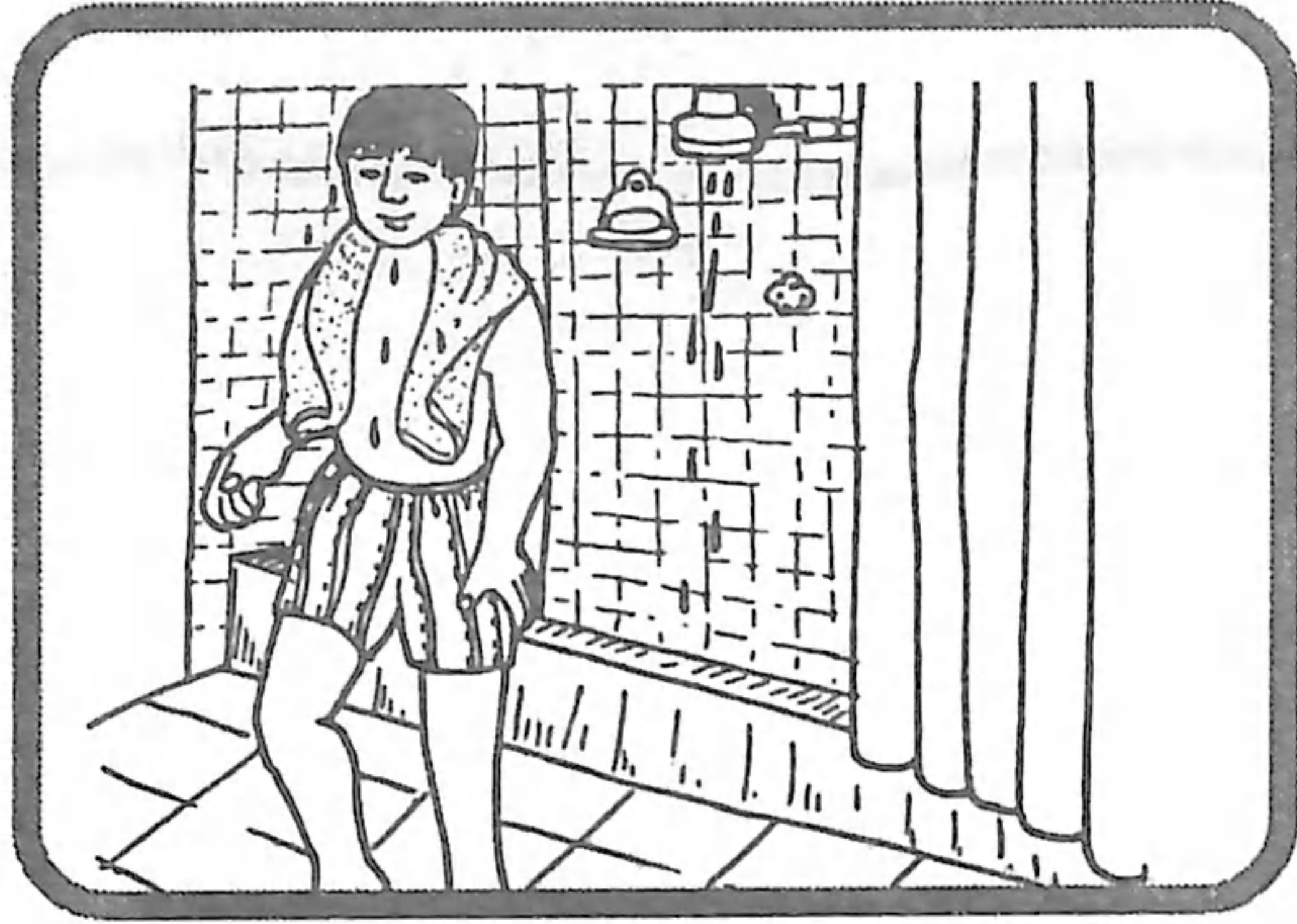

yojatin

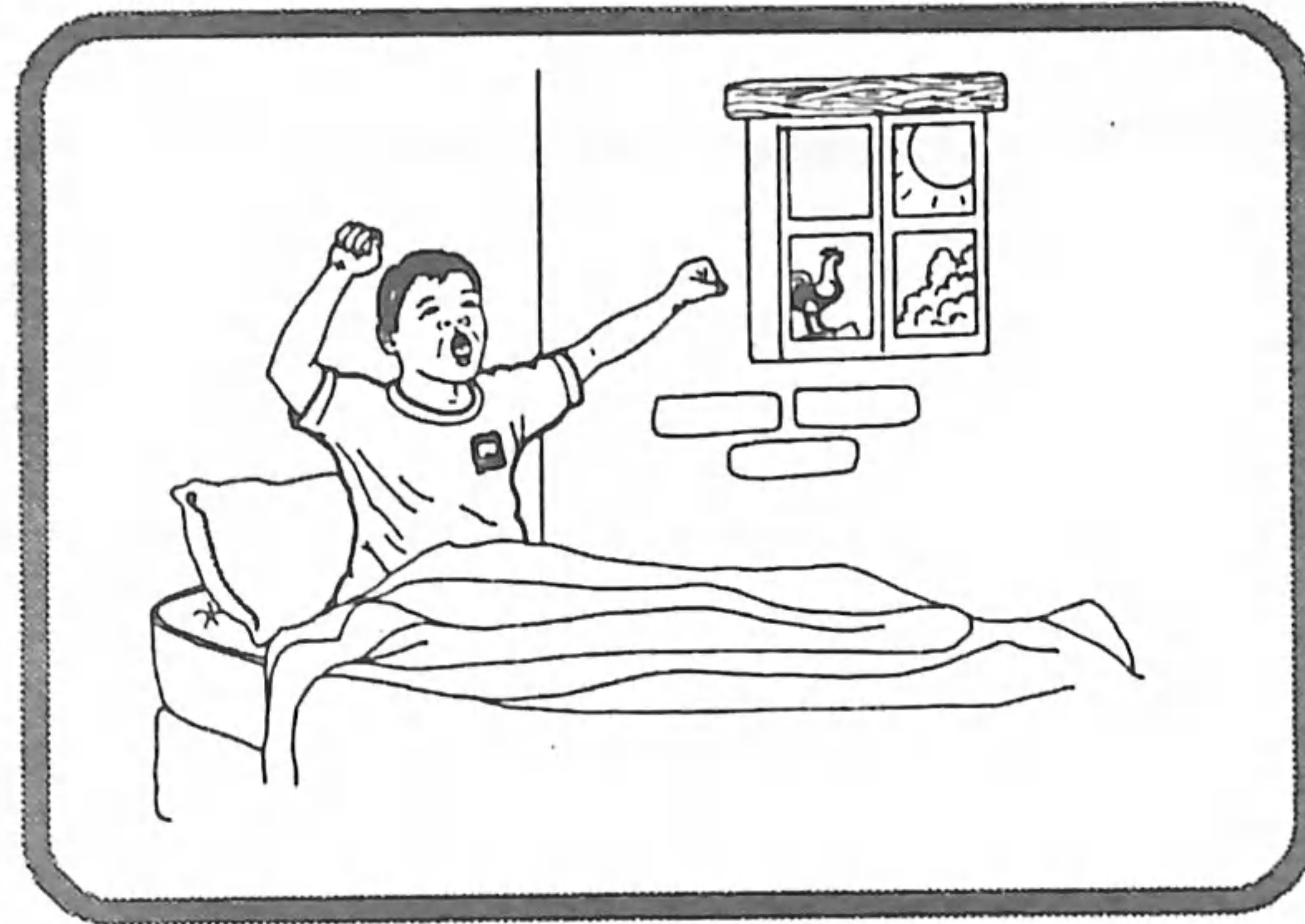

yojwär



Yojuxlan

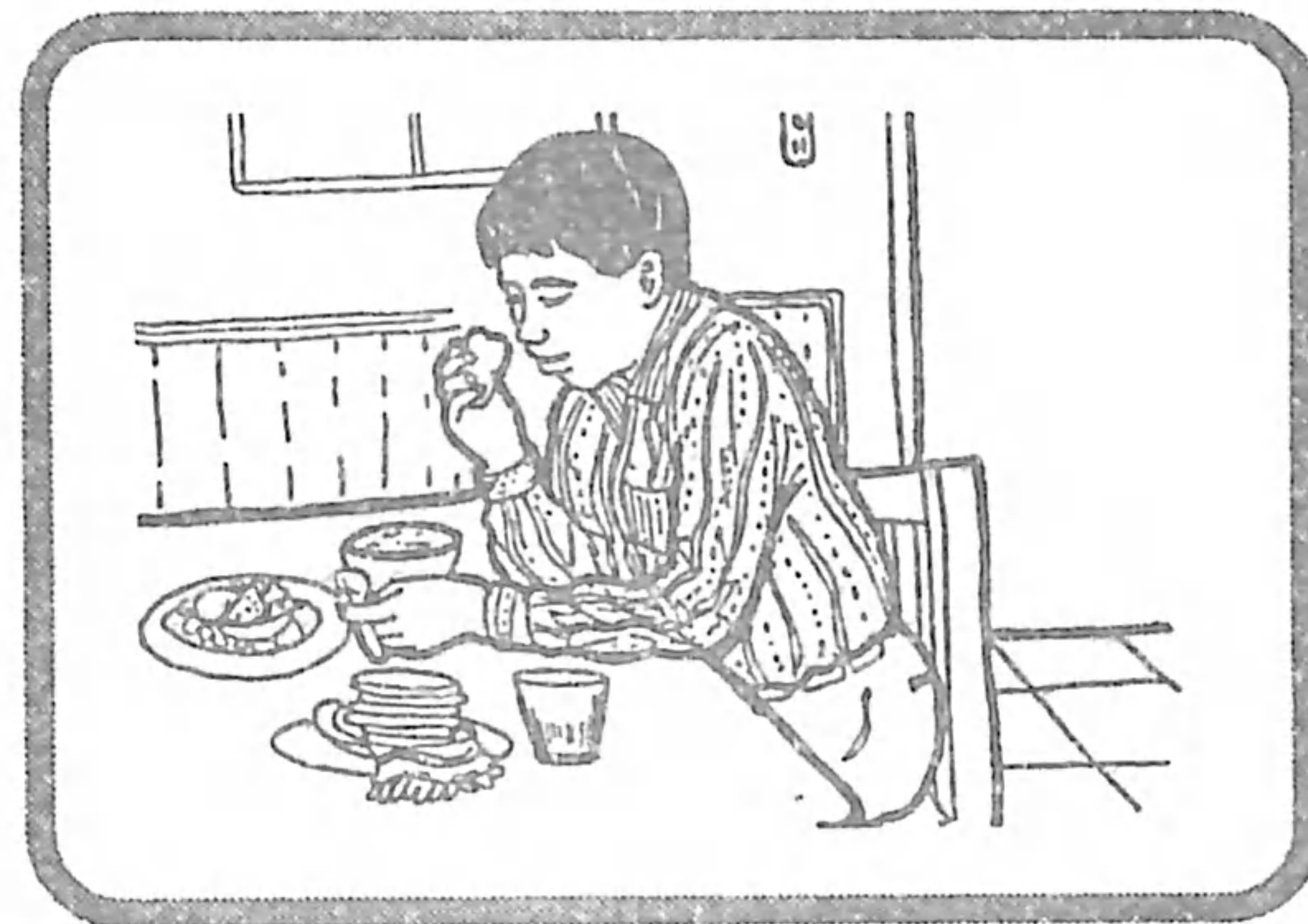

Yojwa'

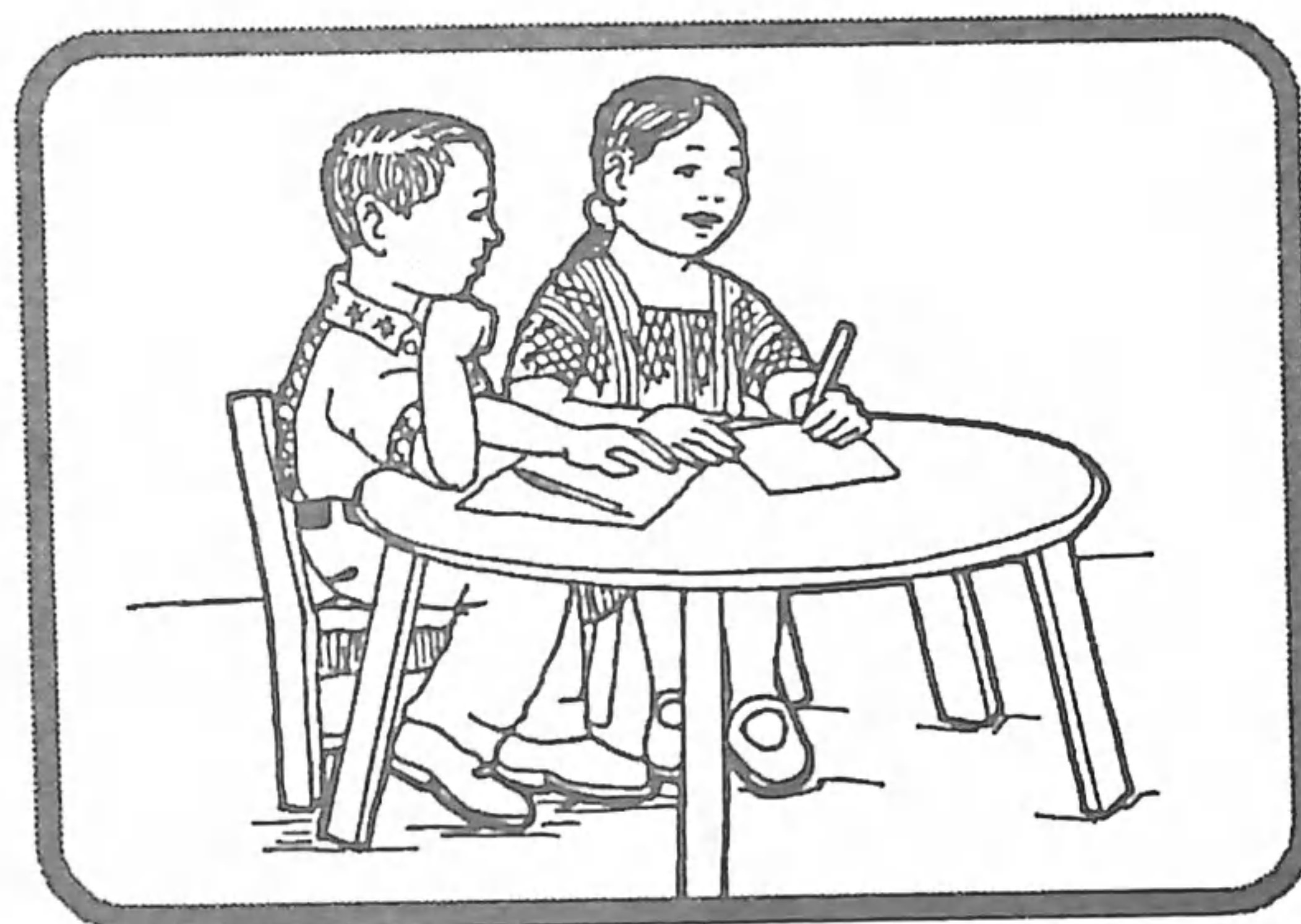

Nqasik'ij wuj

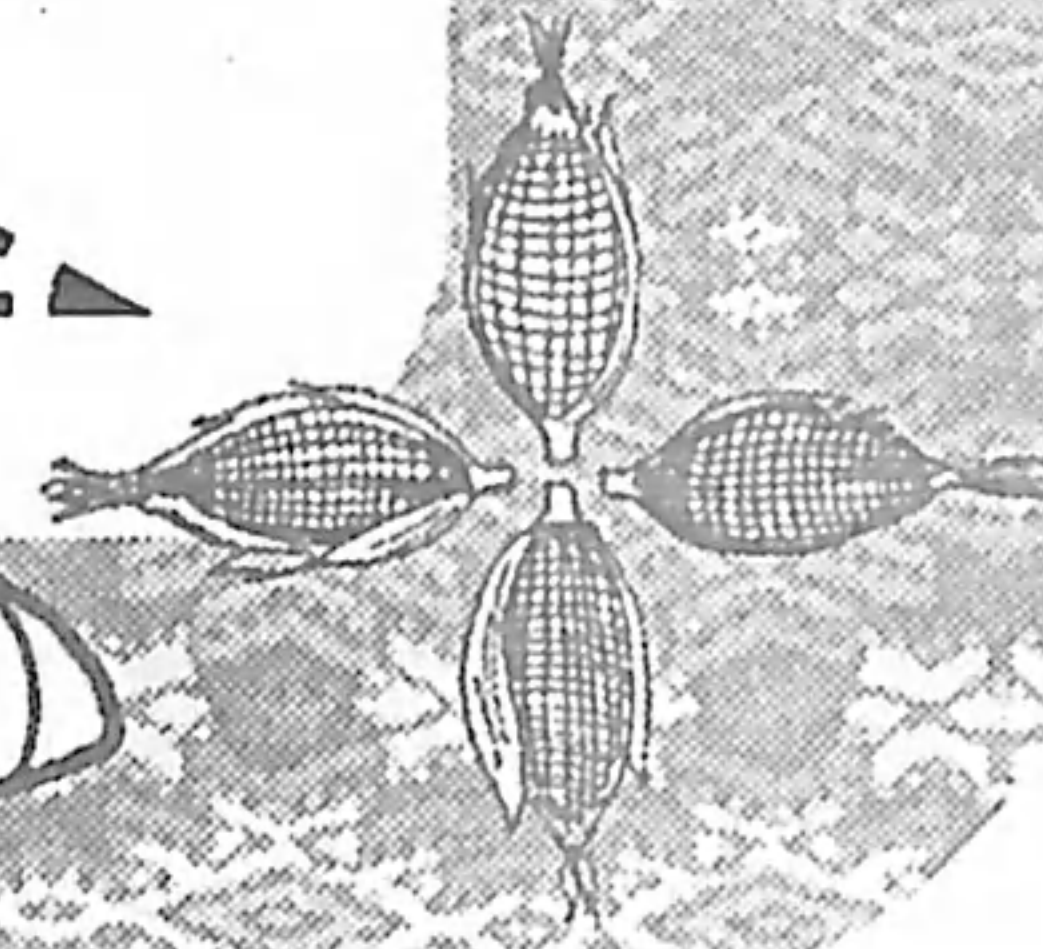
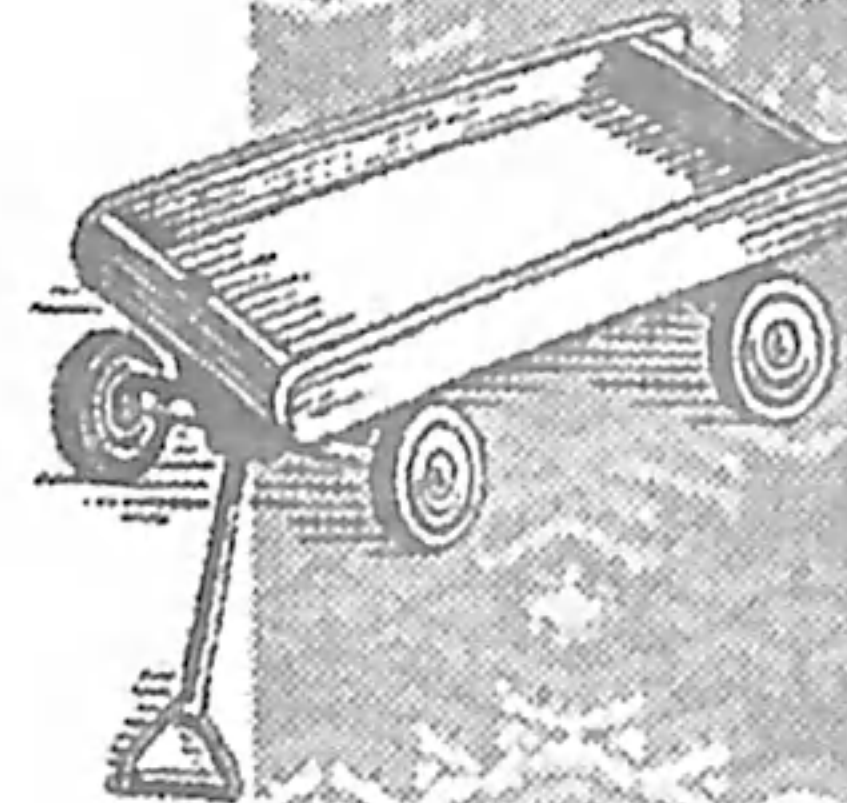

Ri tijoxela' yetzijen pa kaka' pa ruwi' rejqalem ri qochoch.





# Ruch'arik jun jay

Nqab'an rachib'al rupam jun jay .

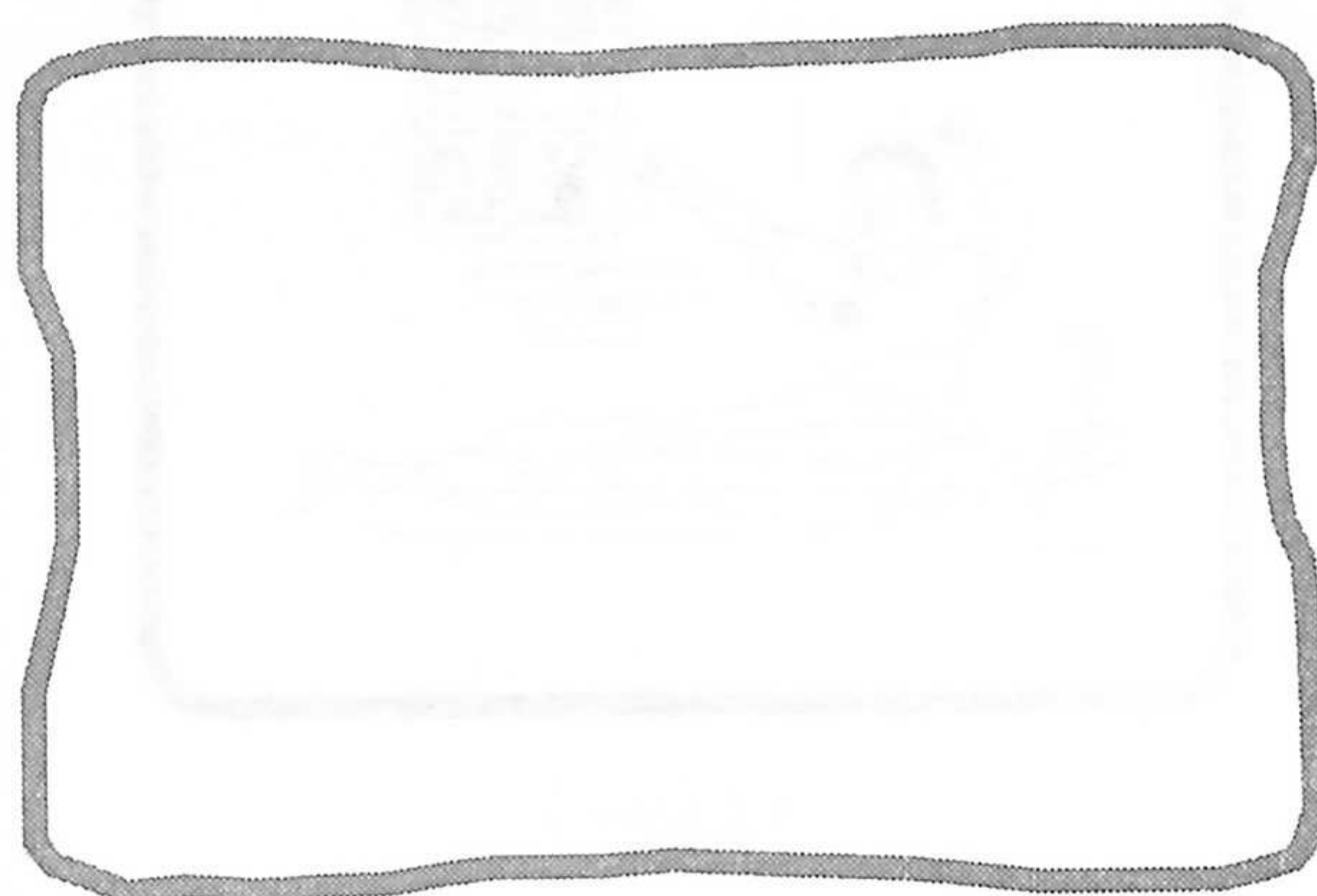

Nimajay

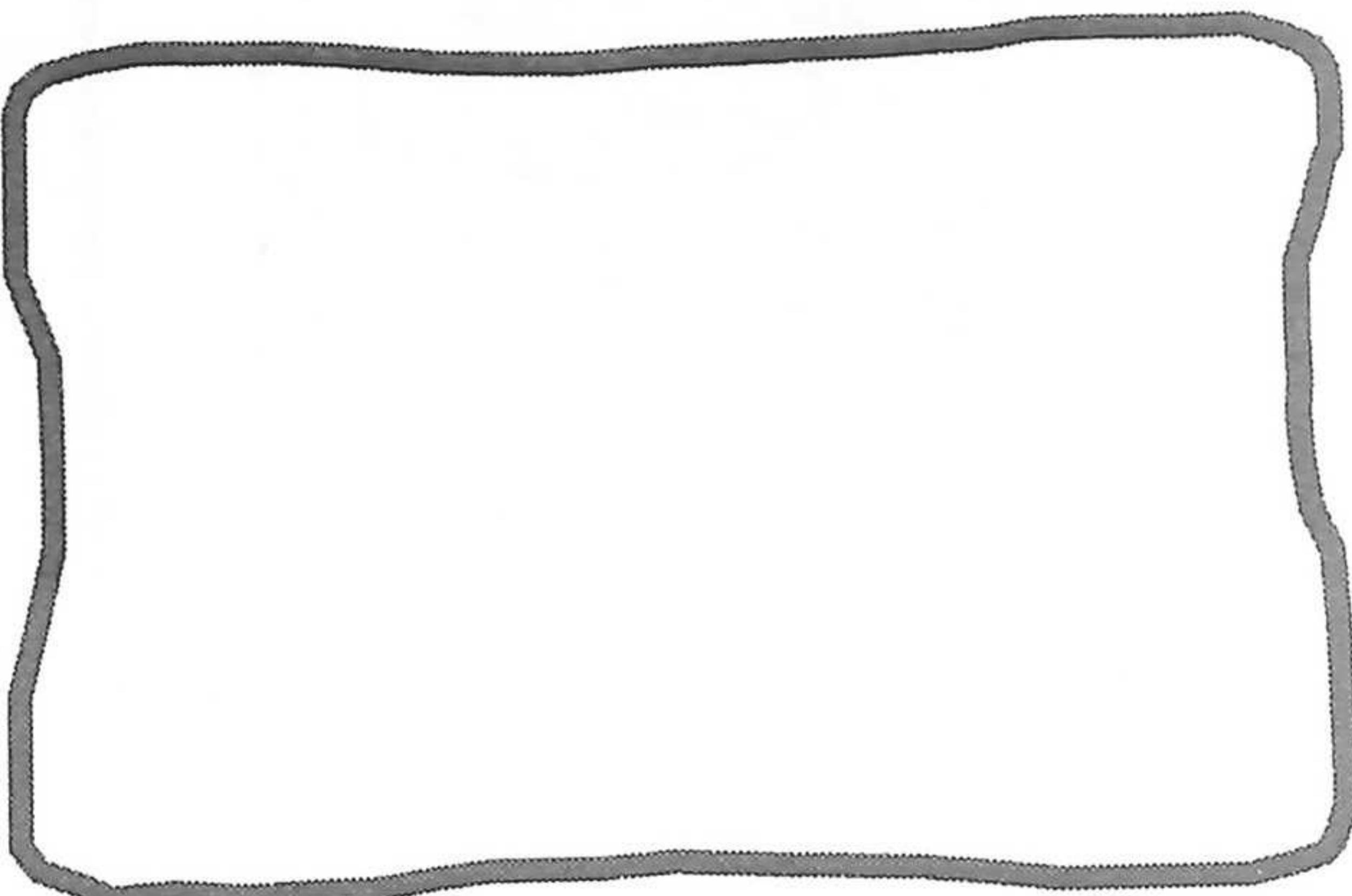

Warab'al

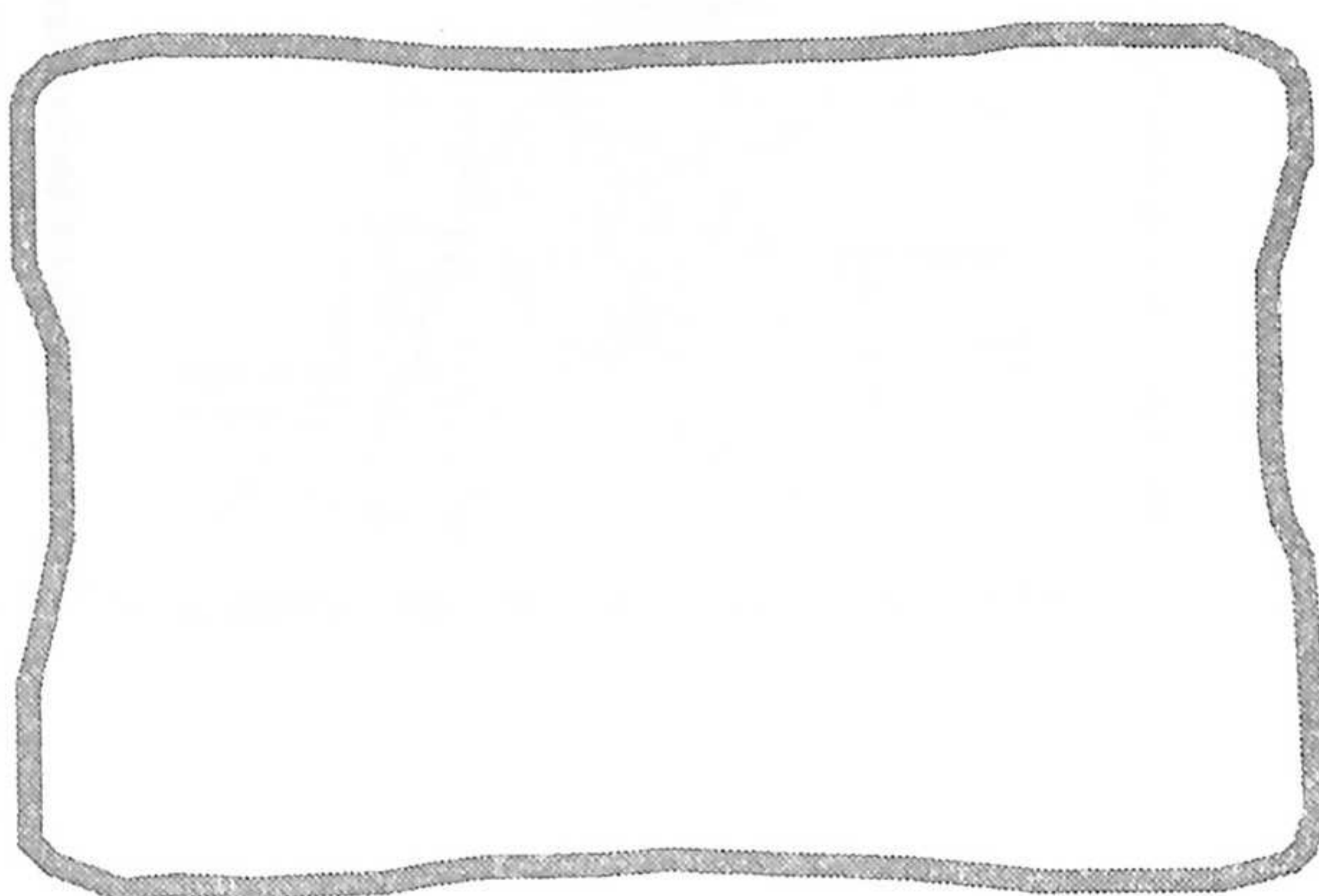

Rute' q'aaq'

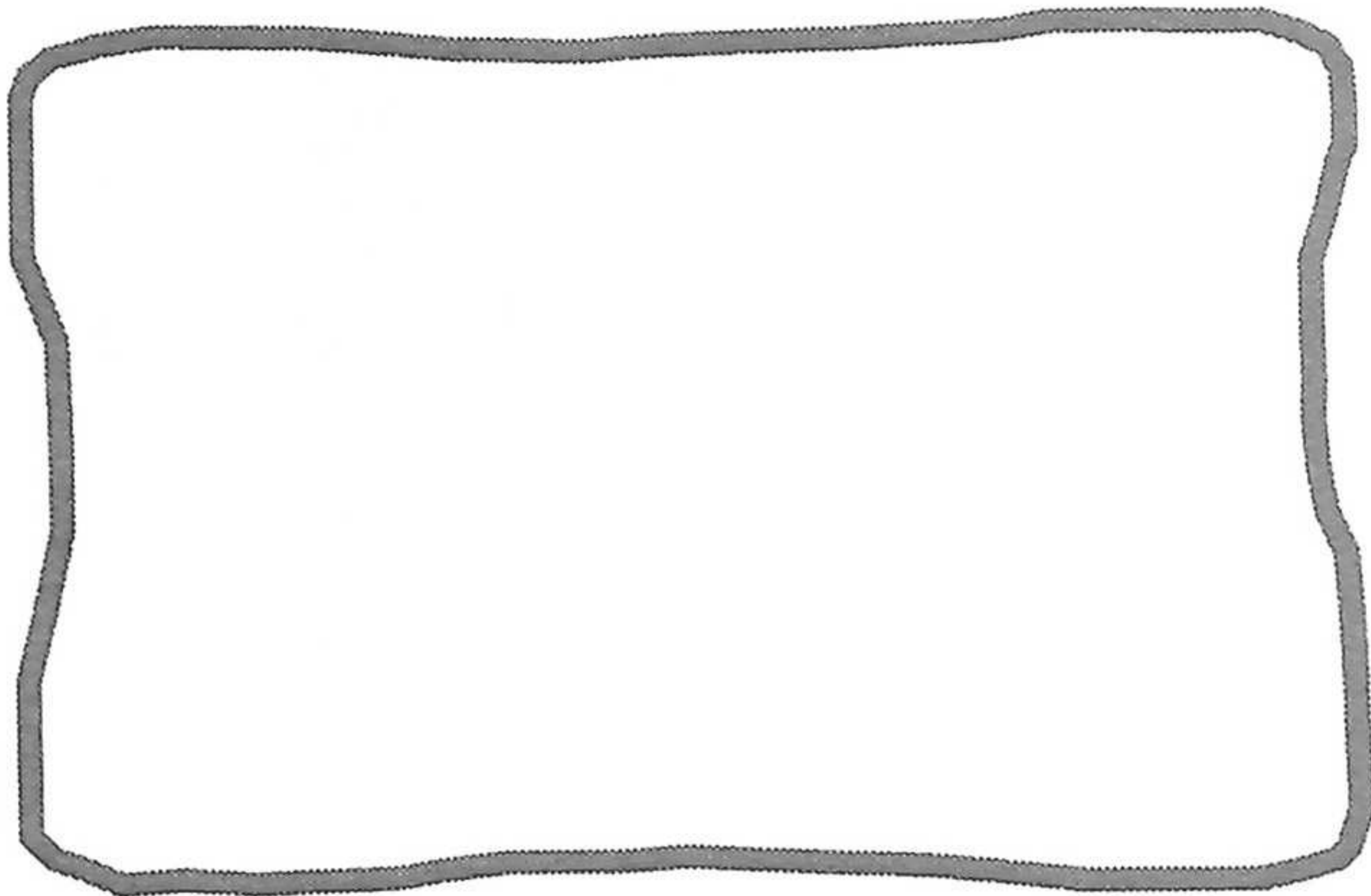

Wayb'al

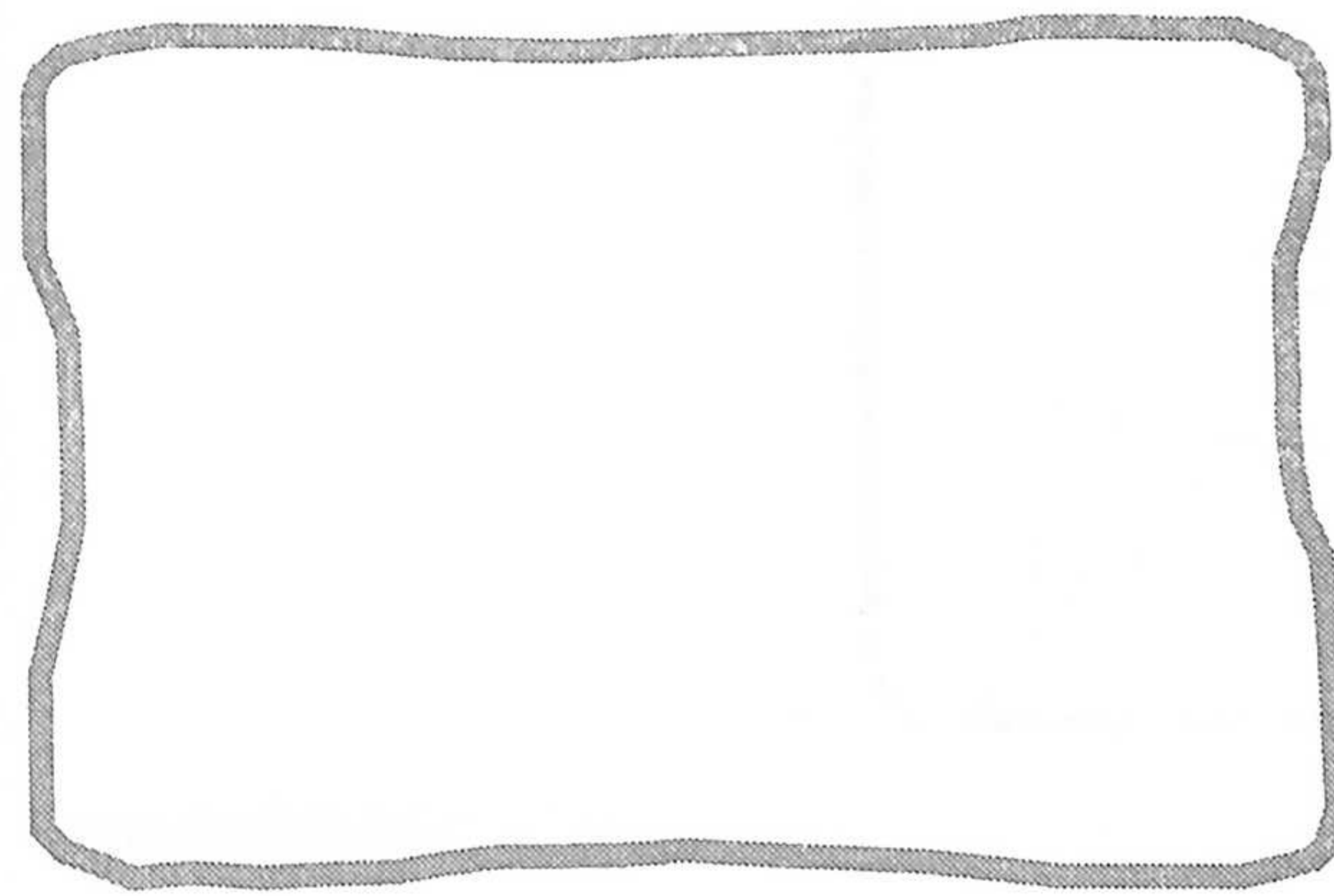

Ruwajay chuqa' kotz'ib'al

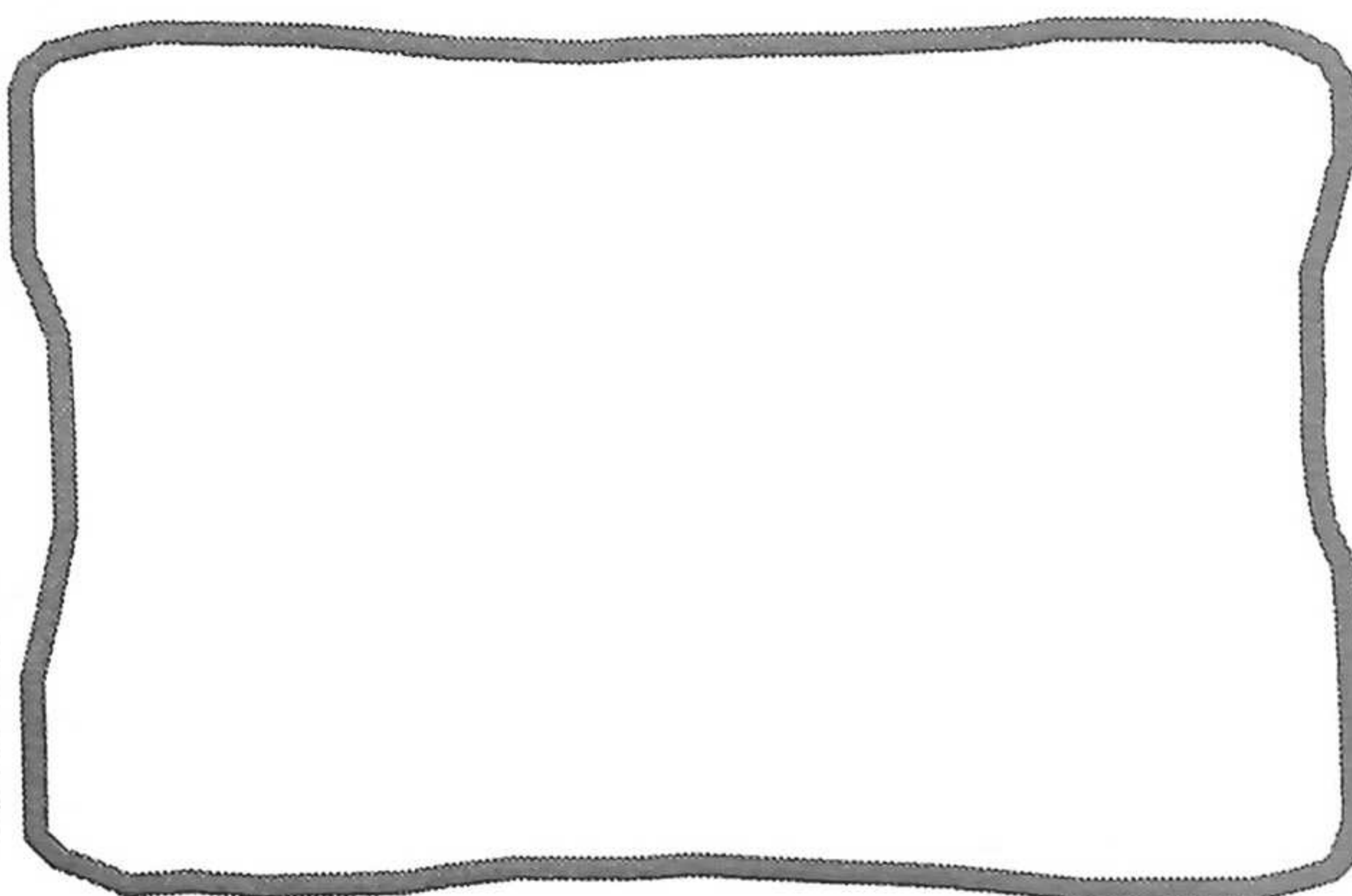

Ruxikin jay

Ri tijoxela' yesamaj pa kaka' richin nkib'an rachib'al ruch'arik jun jay.



Project: ...

# Kojtzijon pa ruwi' ri qochoch



Re' wochoch rin

La la' awochoch rat

Re re' rochoch rija'

Re re' qochoch röj

La la' iwochoch rix

La la' kochoch rije'

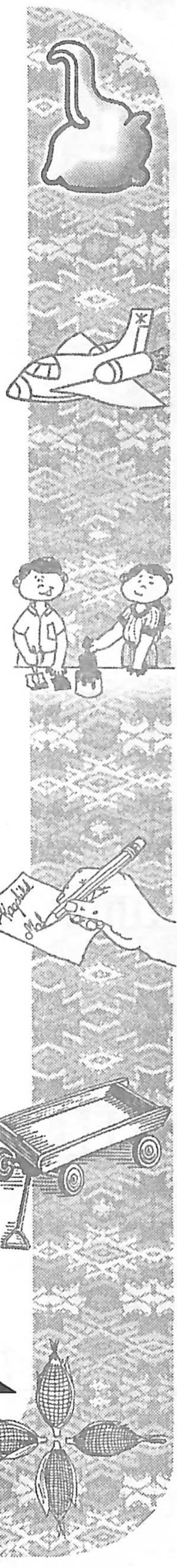
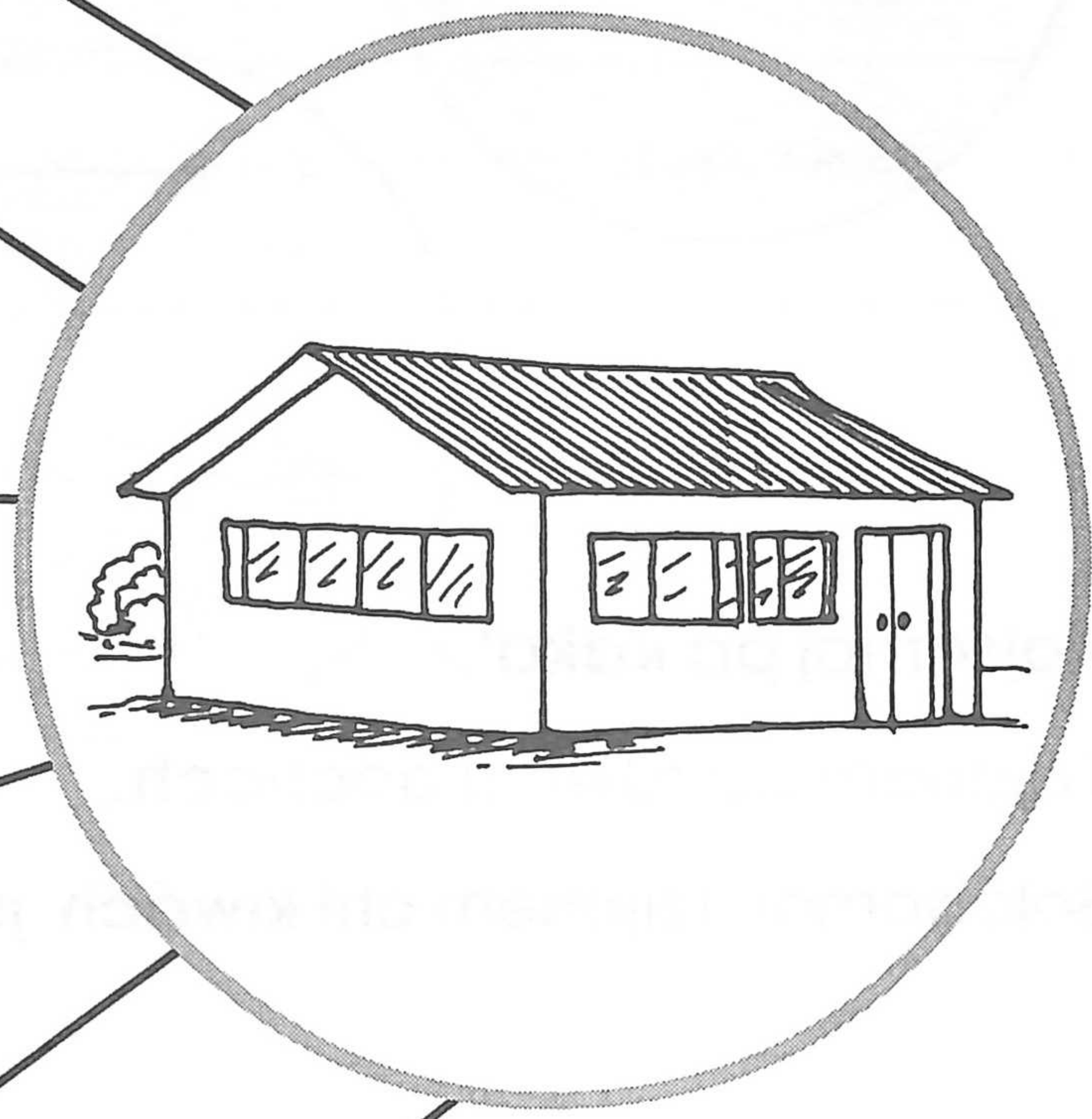

Ri tijonel, chuqa' ri tijoxela' yetzijon pa ruwi' ri ichinanel t'as, chuqa' tikirel nkib'än jun jay richin yetzijon pa ruwi'.





# Ri nqab'än röj pa qochoch



**Kojsamäj pa kaka'.**

**Tzjonem pa ruwi' ri qochoch.**

**Solojsamaj: Tzjonem chi kiwäch jun ixtän rik'in jun ala'.**

- Ixtz'ulu': -Achike nab'än pa awochoch ronojel q'ij Saqb'alam?
- Saqb'alam: -Rin ninb'än jalajöj nusamaj.
- Ixtz'ulu': -Rin ninb'än kan nusamaj nimaq'a'.
- Saqb'alam: -Rin ninxo'z'o'.
- Ixtz'ulu': -Rin ninto' ri nutata' pa juyu'.
- Saqb'alam: -Rin yinetz'an chuqa'.
- Ixtz'ulu': -Töq yakolaj nach'äj avey?
- Saqb'alam: -Ja'. Rat chuqa'?
- Ixtz'ulu': -Ja', chuqa' töq yinwär qa.
- Saqb'alam: -Chuwa'q chik k'a.

Ri tijoxela' yetzjon chi kiwäch.

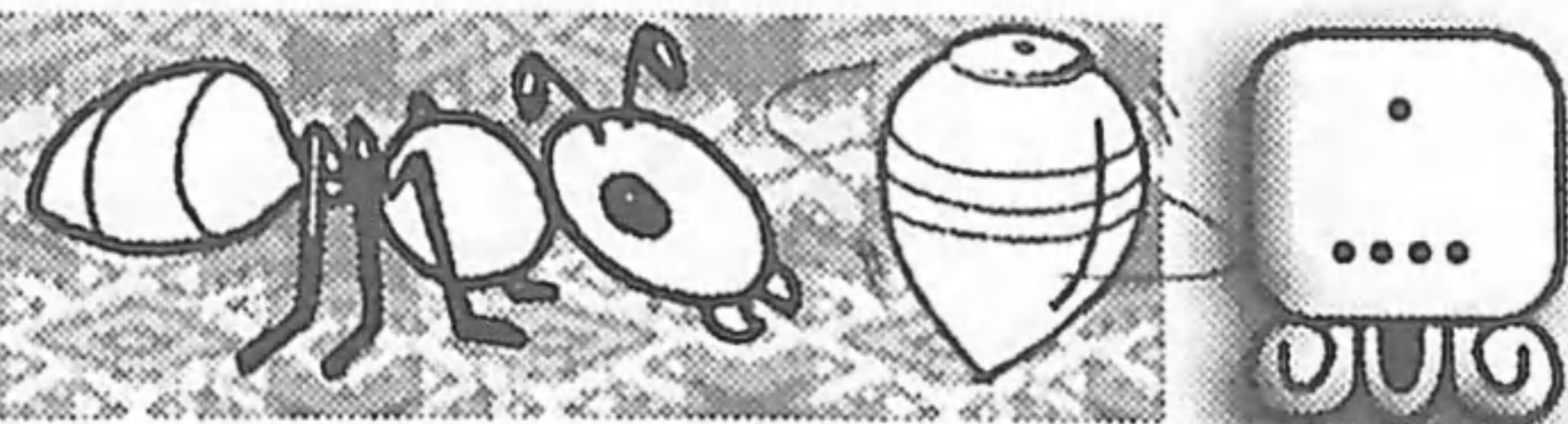

Ja re' ri jujun wachinäq ri e okisan richin kib'anon jun jay.

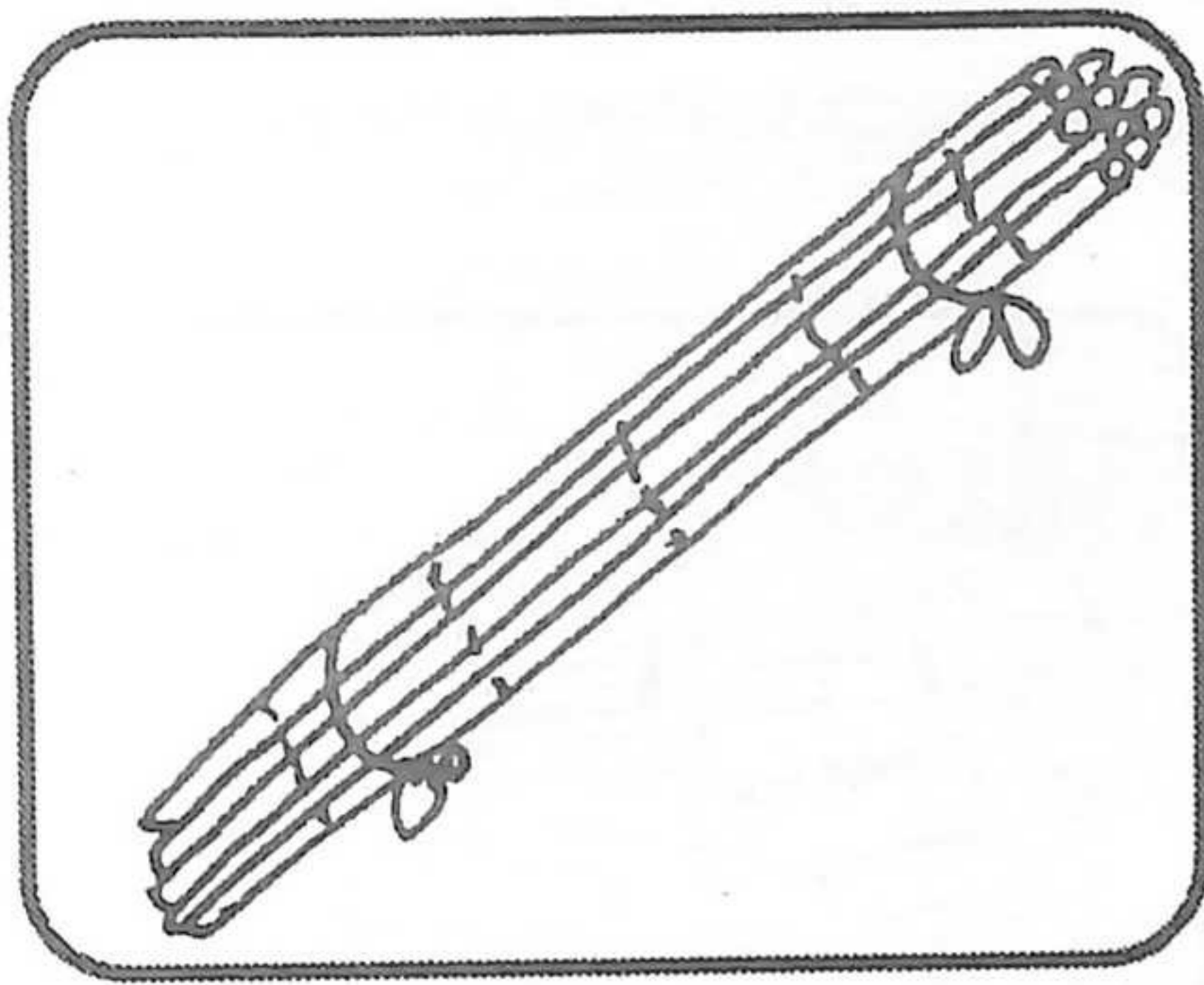

patz'än

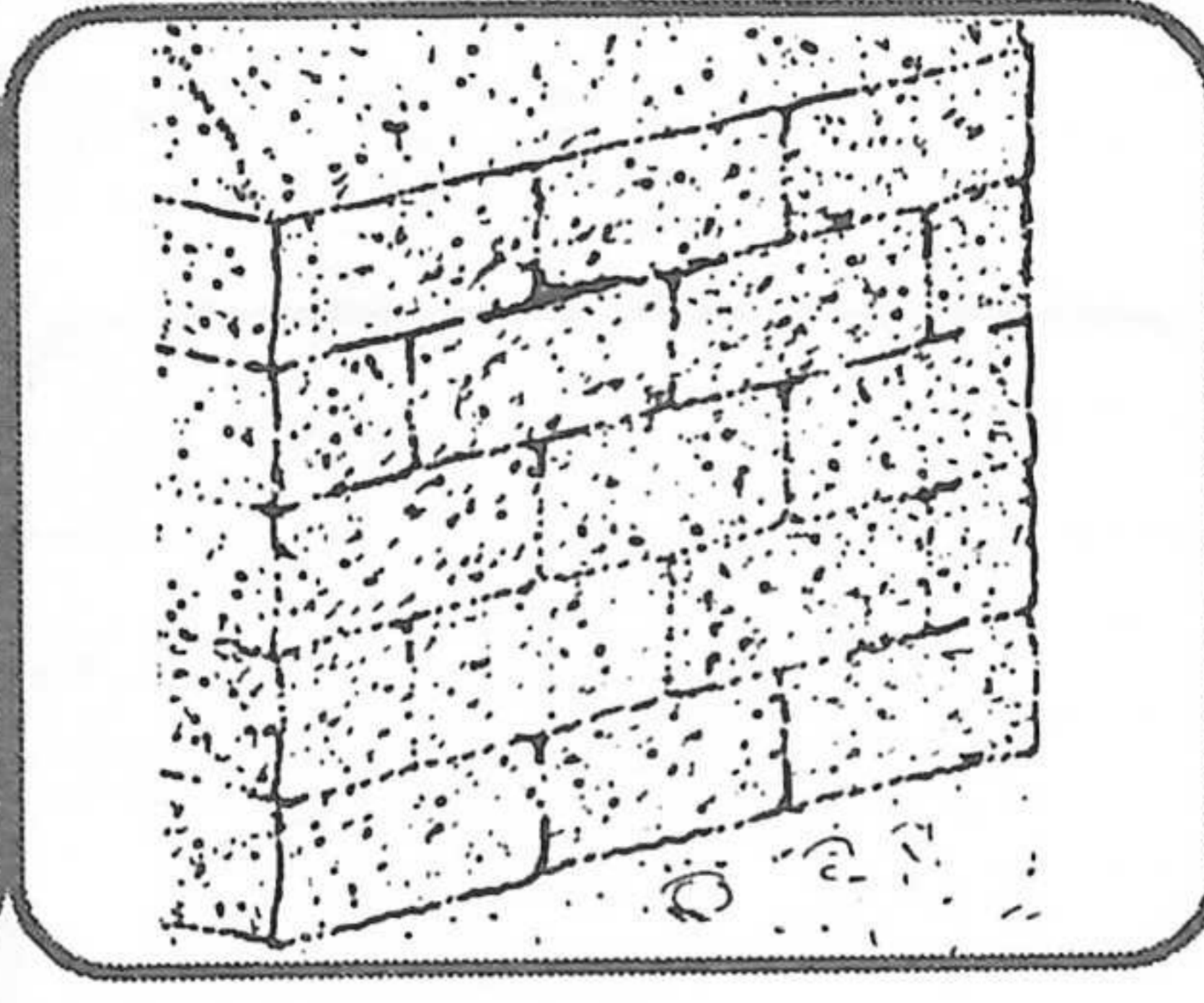

xan

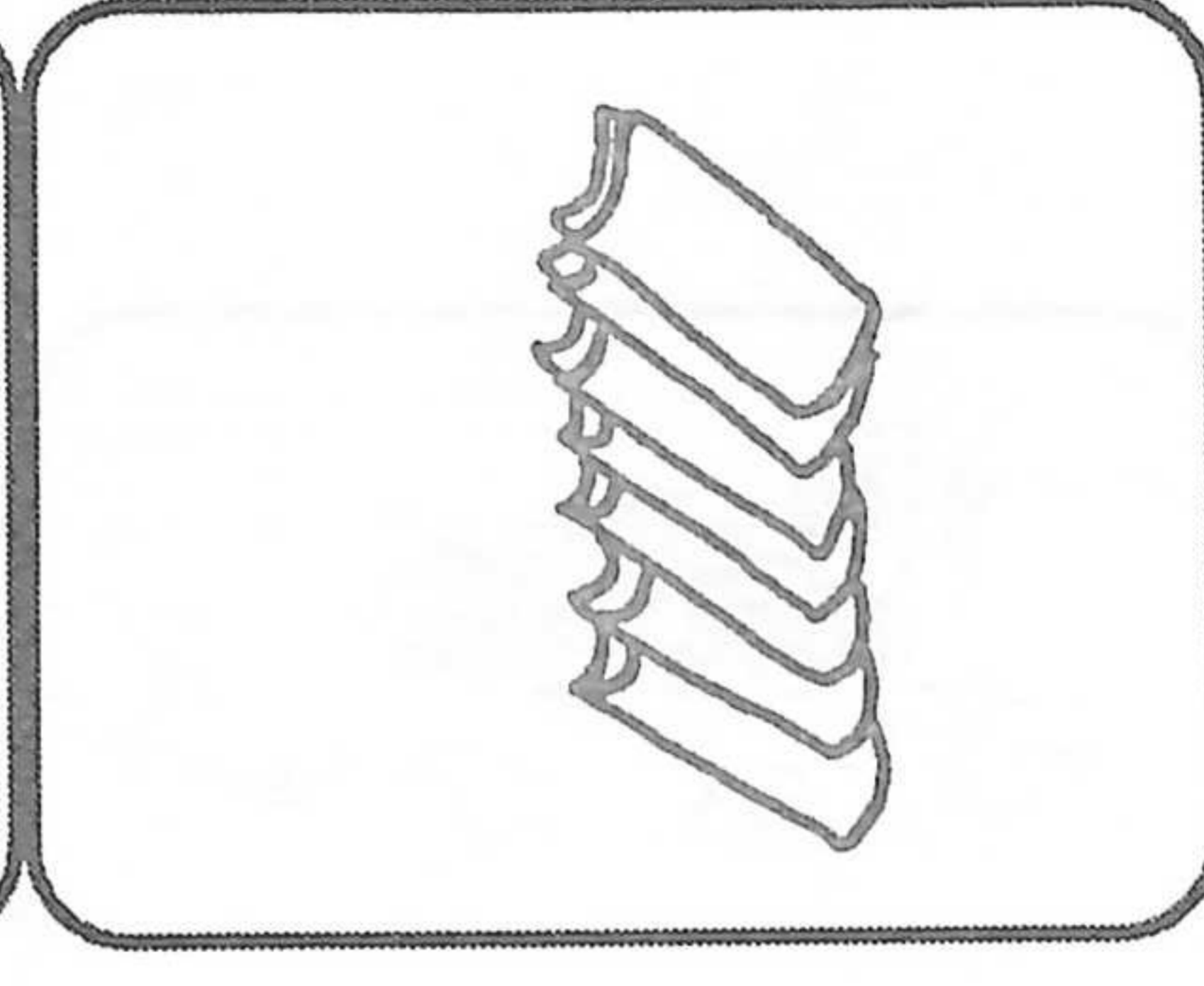

ruxotal jay

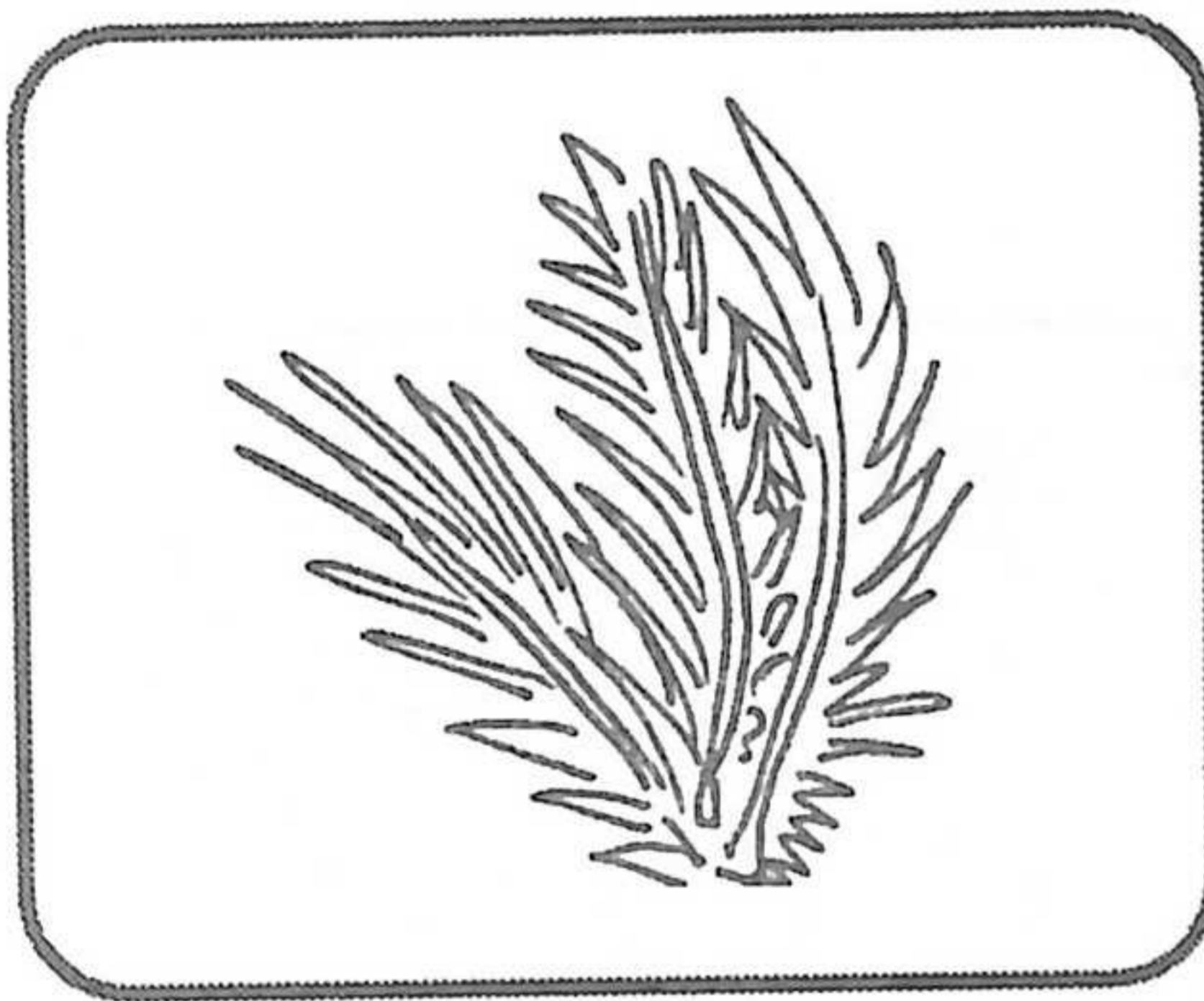

ruxaq k'ib'

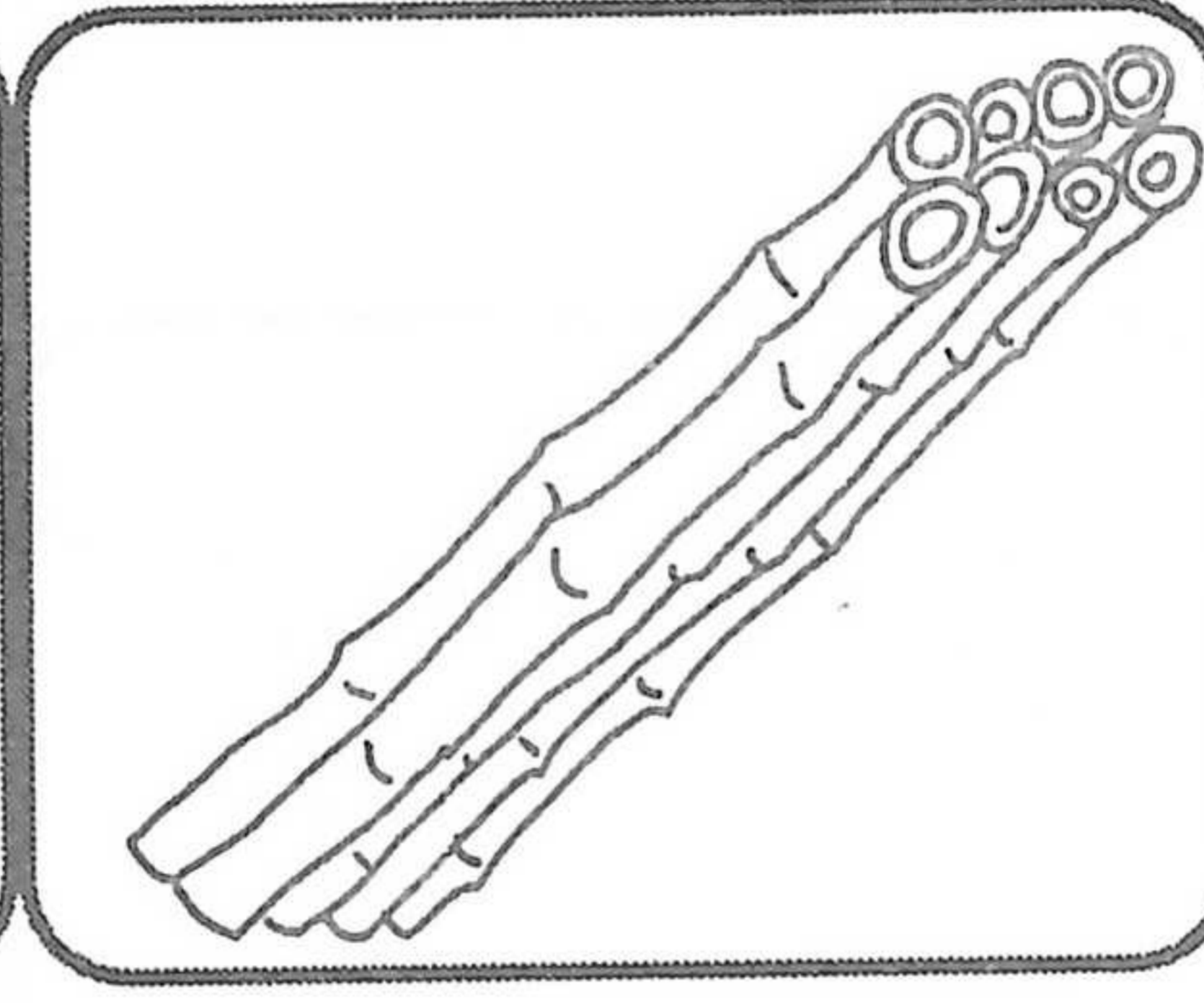

tara'

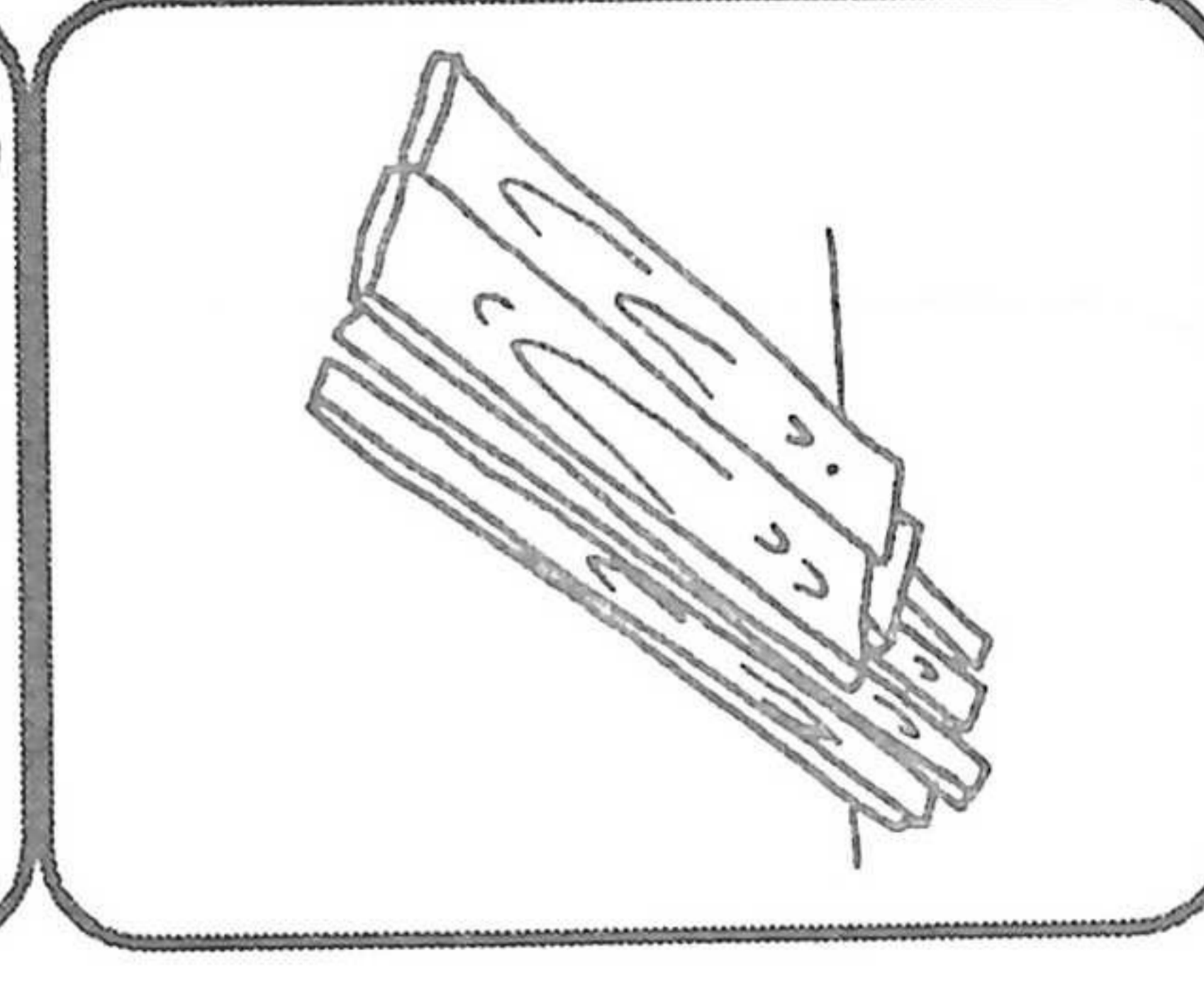

che'

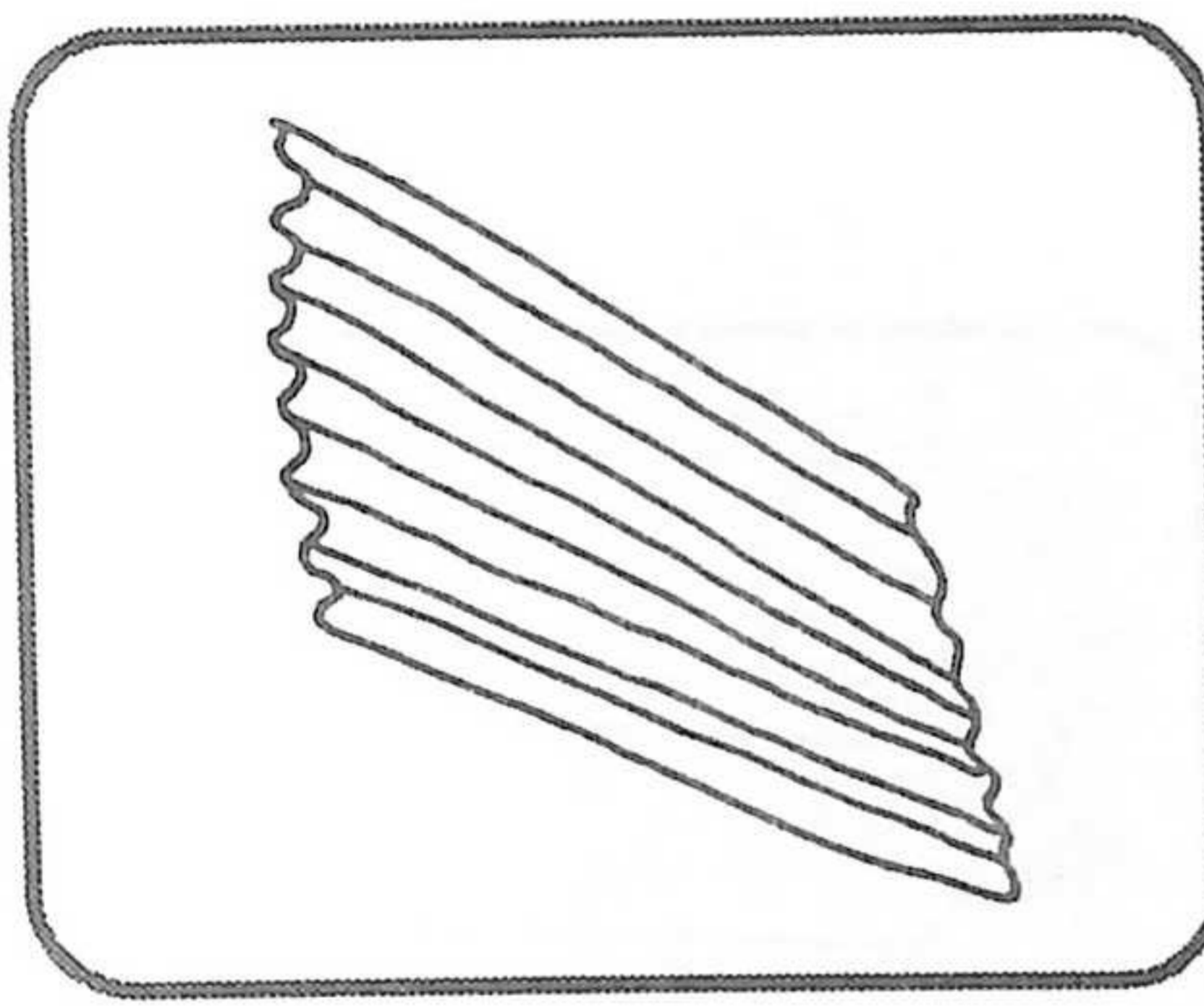

b'ot

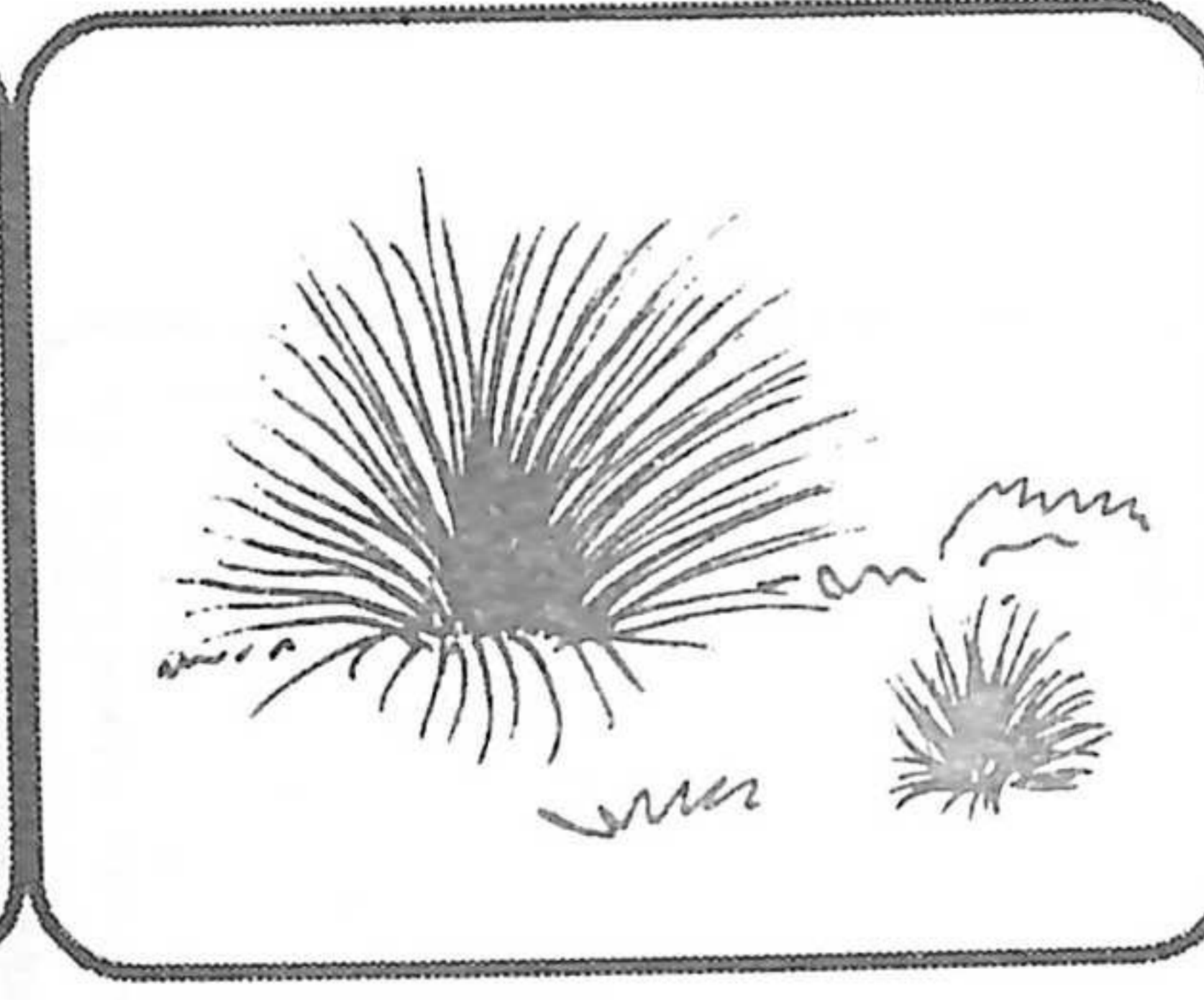

k'im

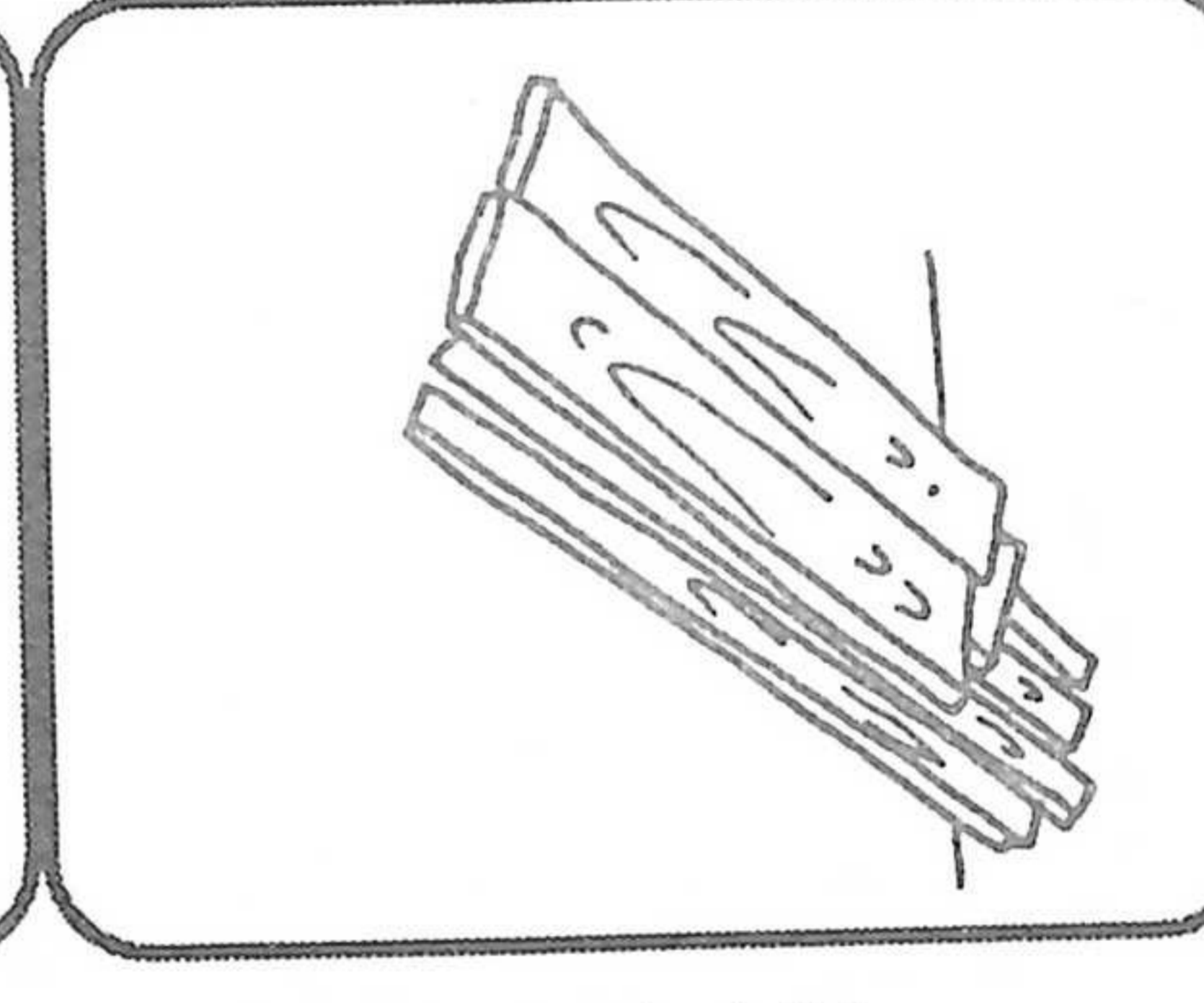

ab'äj

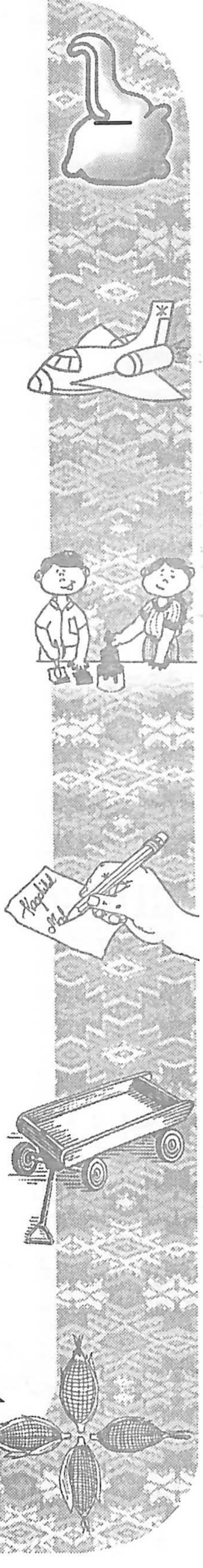

¿Achike wachinäq okisan richin kib'anon ri awochoch rat?

Ri tijoxela' nkikanoj kachib'äl ri wachinäq k'o kib'i' chupam re jun ruxaq wuj re' richin nketamaj ruwäch.





# Wachinäq ri e okisan richin kib'anon jun jay:

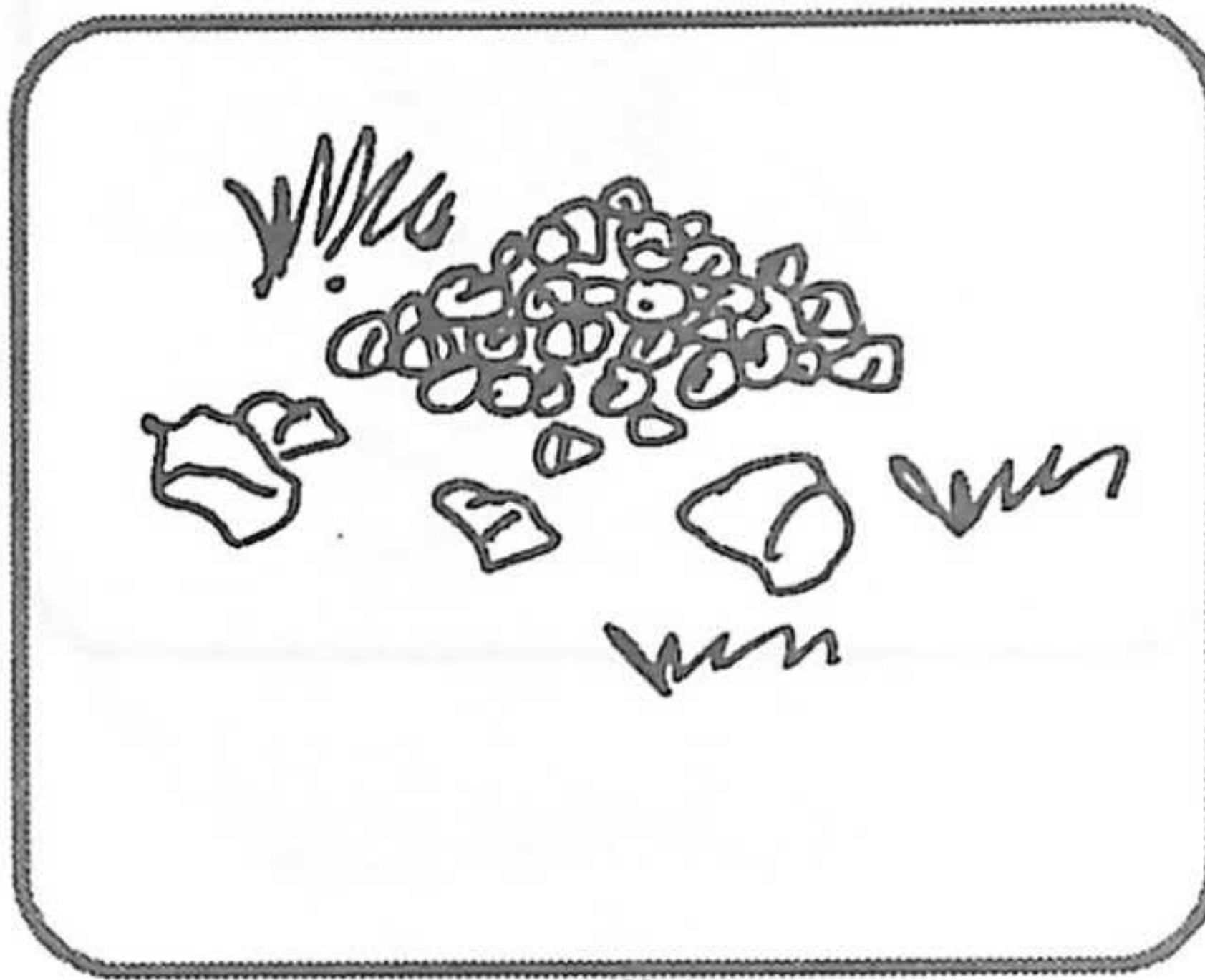

ab'äj

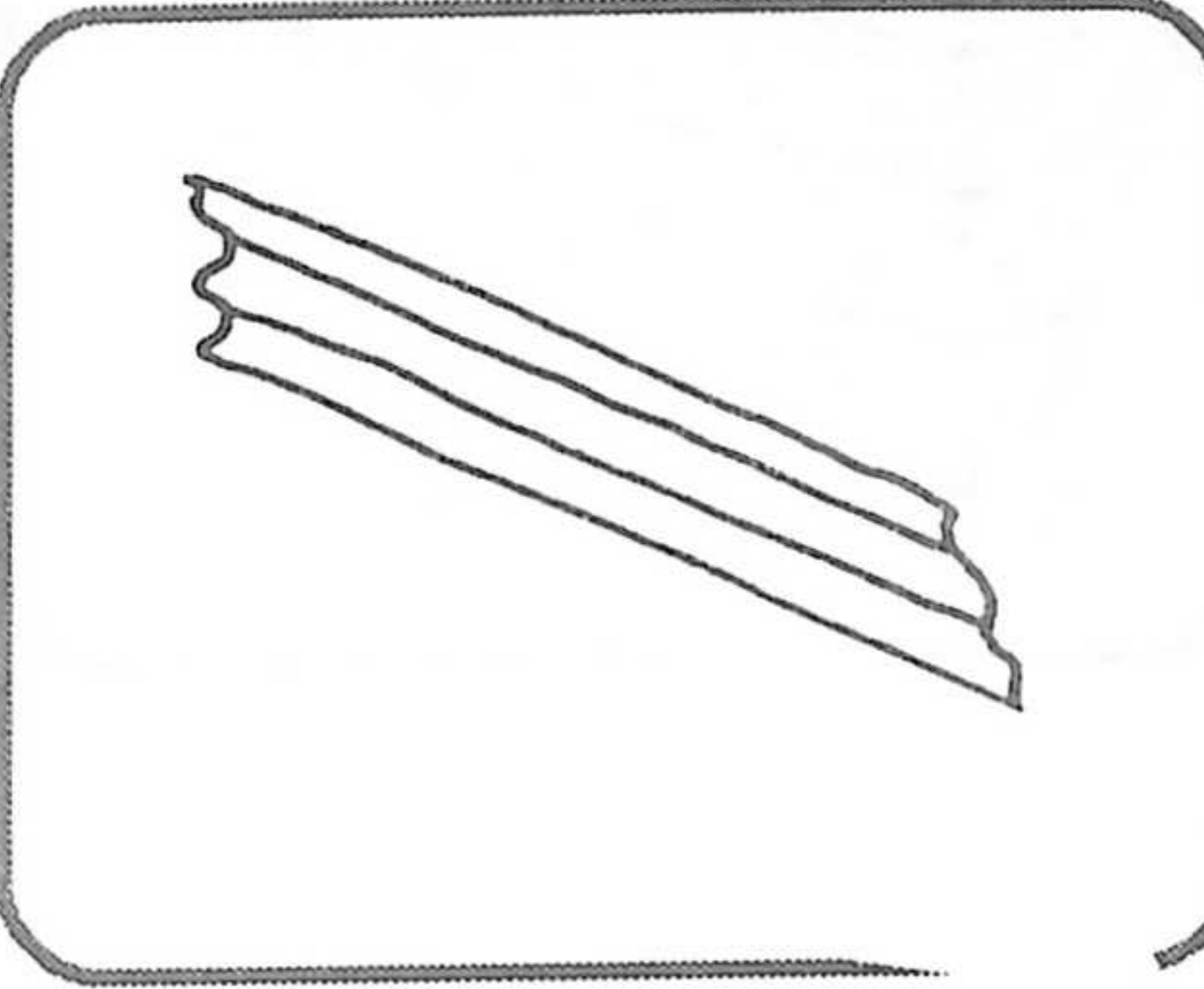

ch'ich'

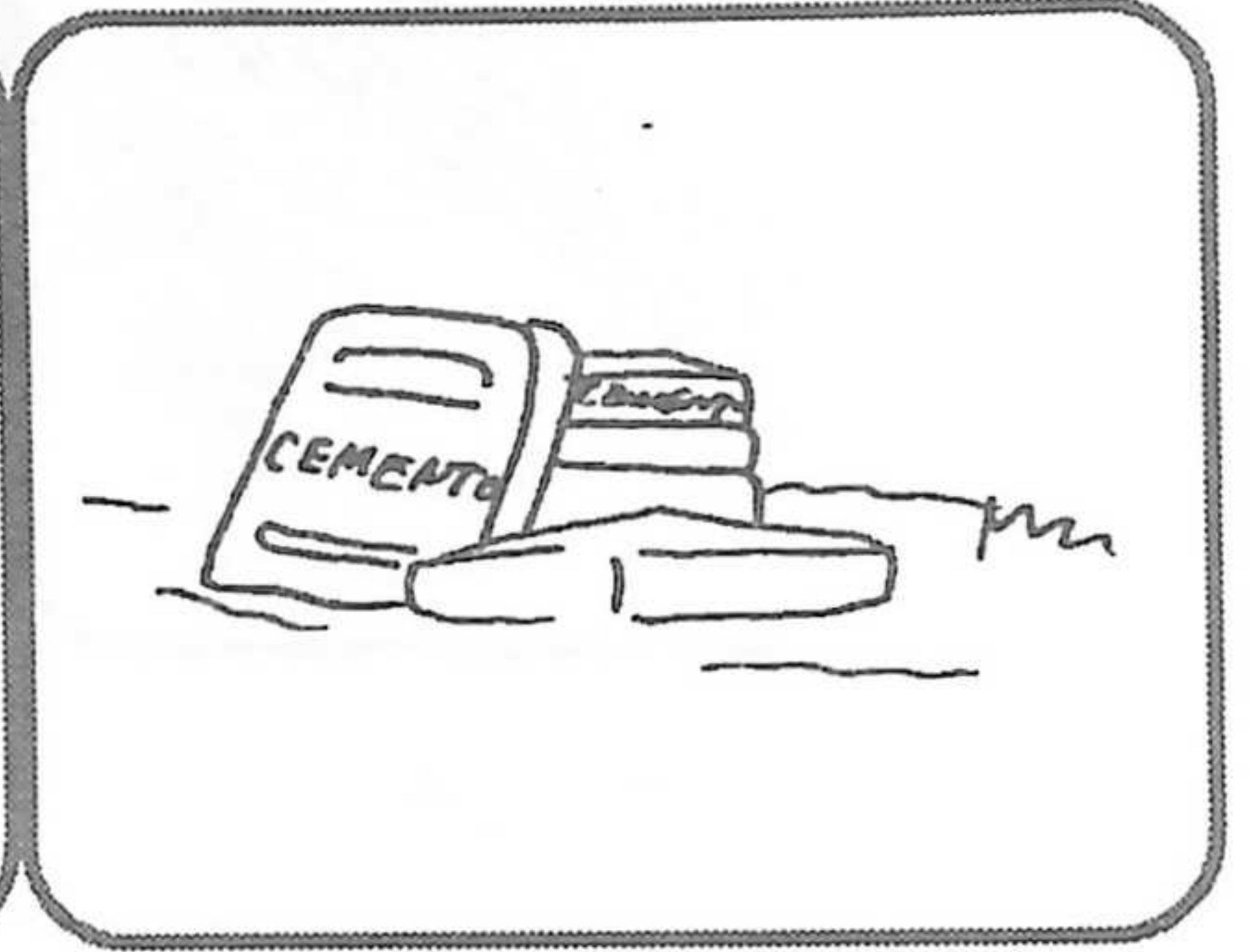

k'ajab'äj

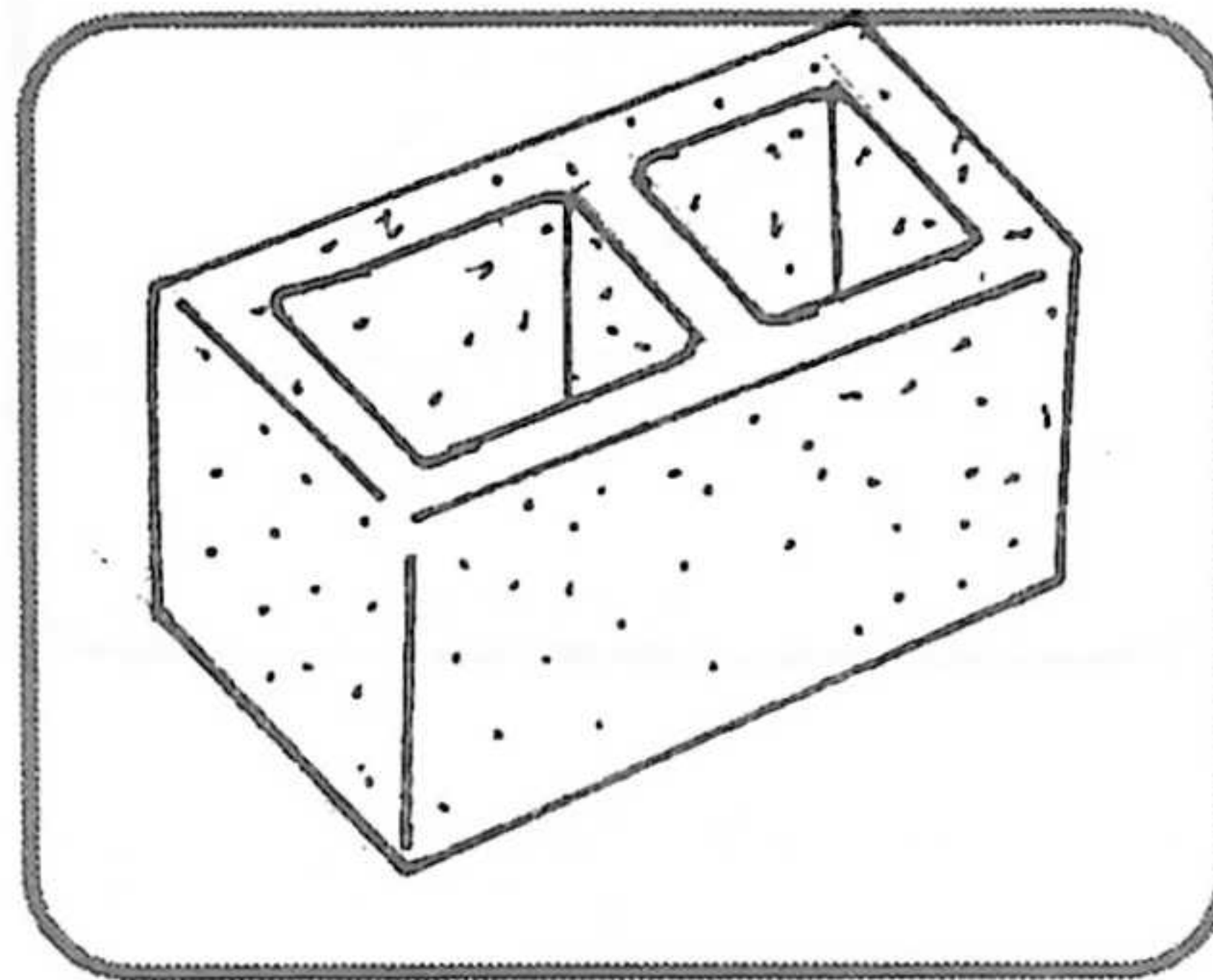

tz'aqon xan

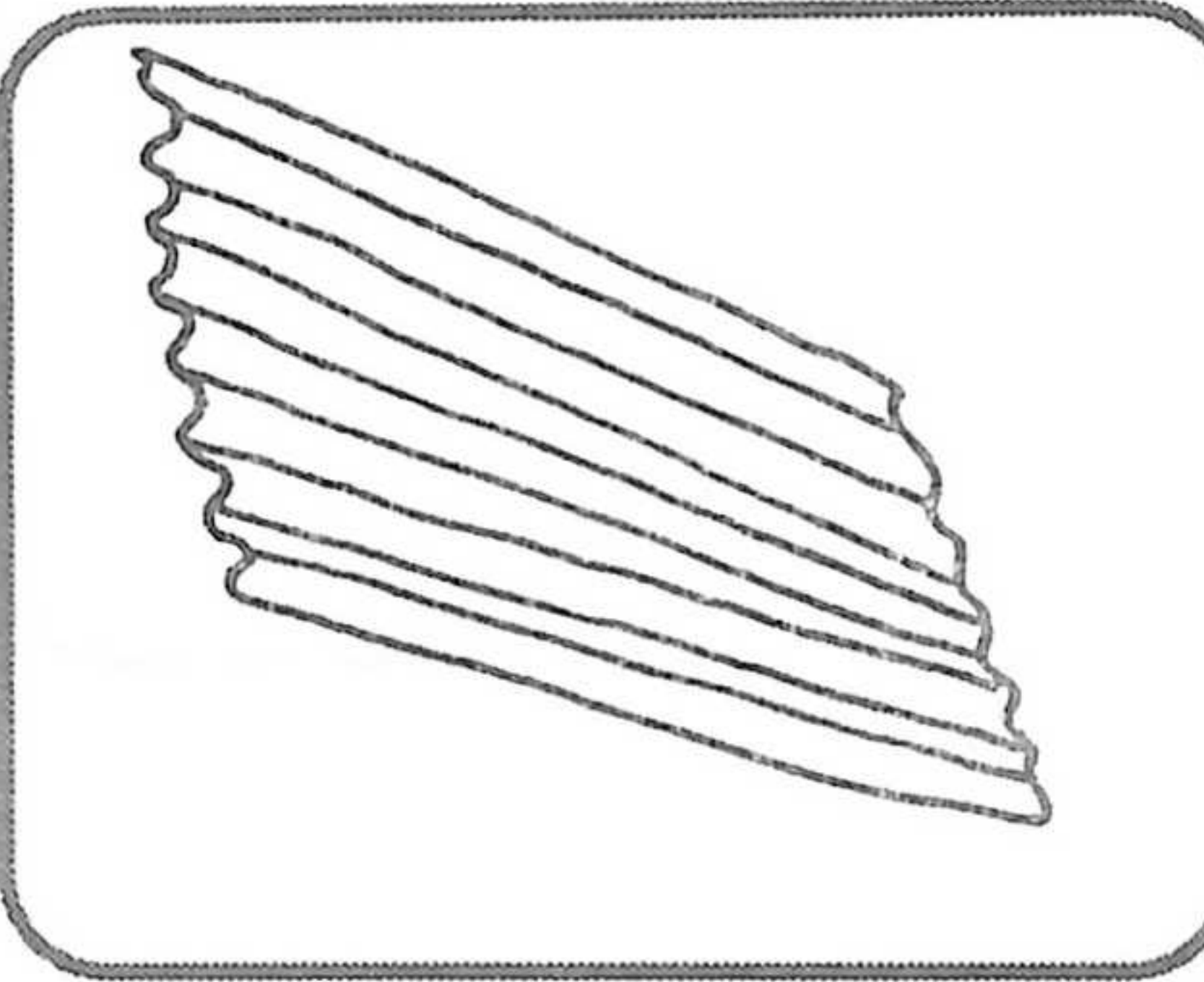

b'ot

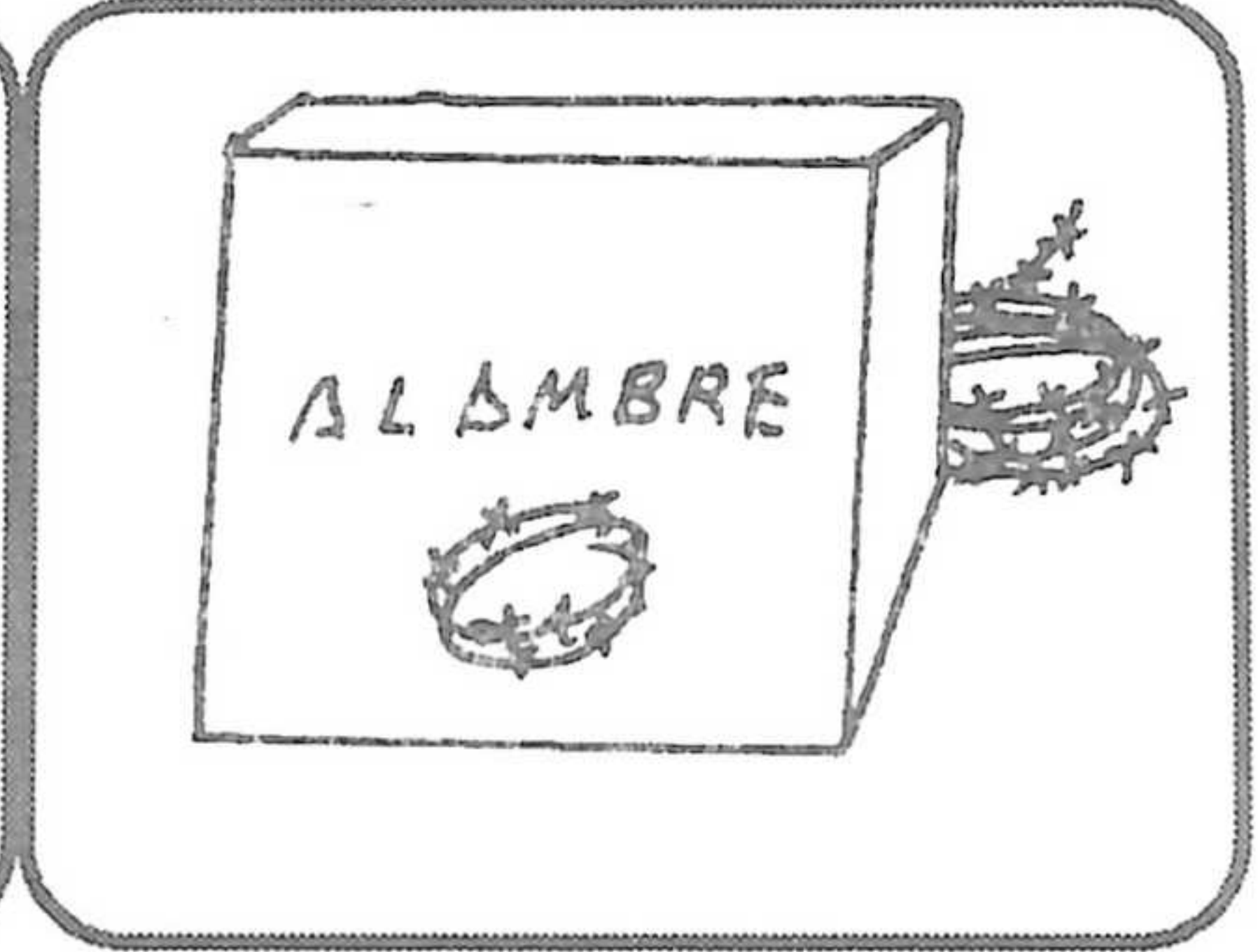

k'amach'ich

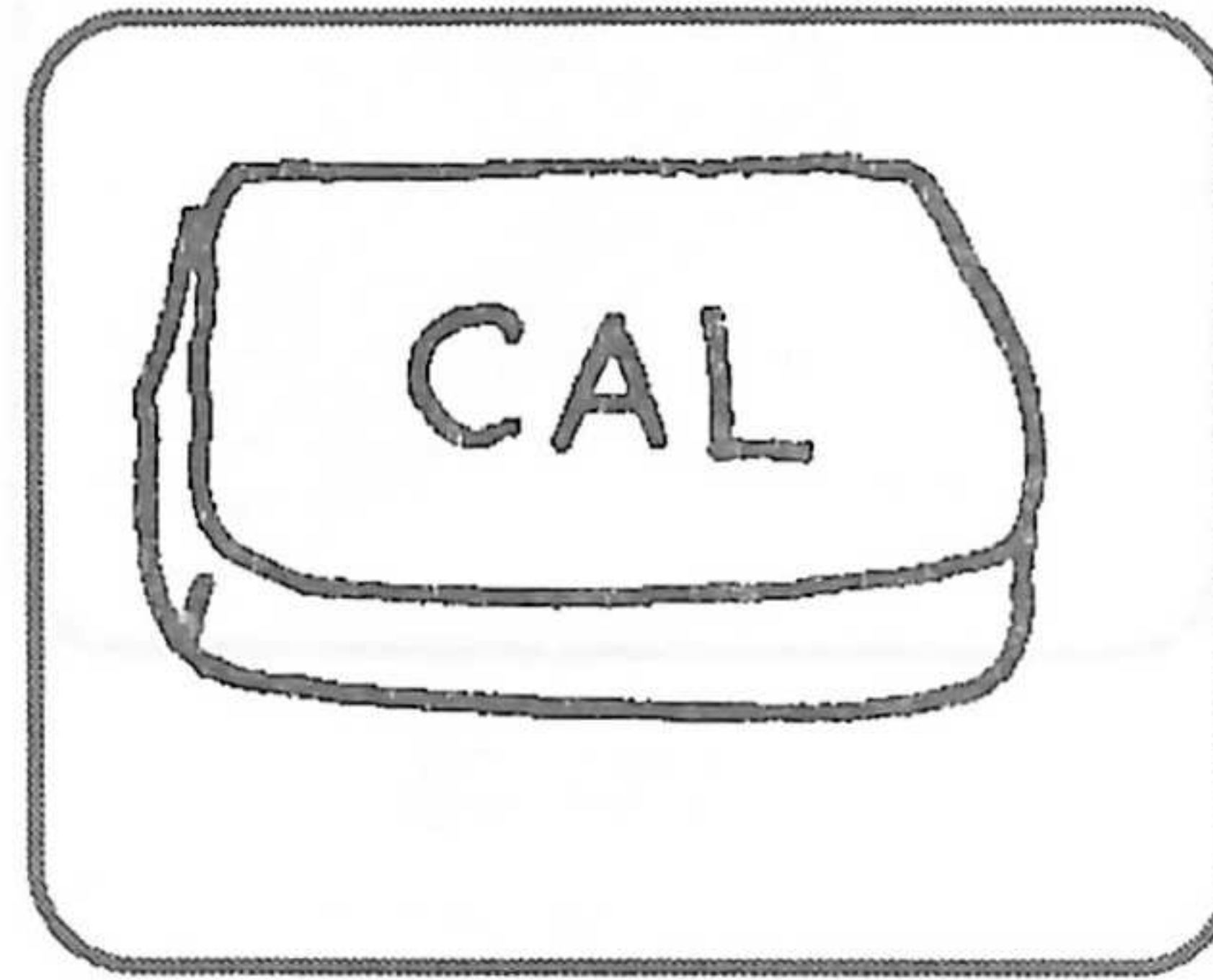

chum

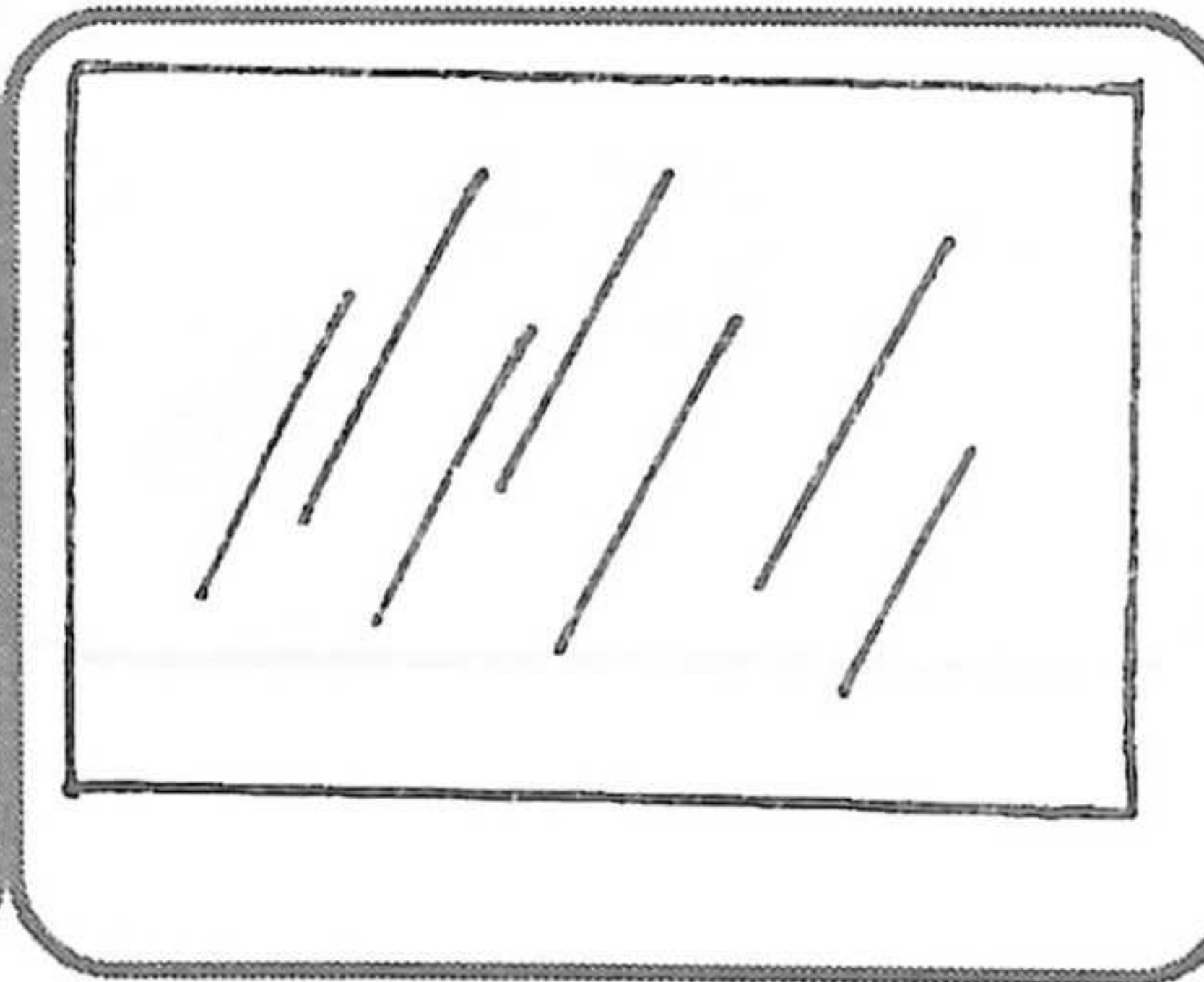

lemow

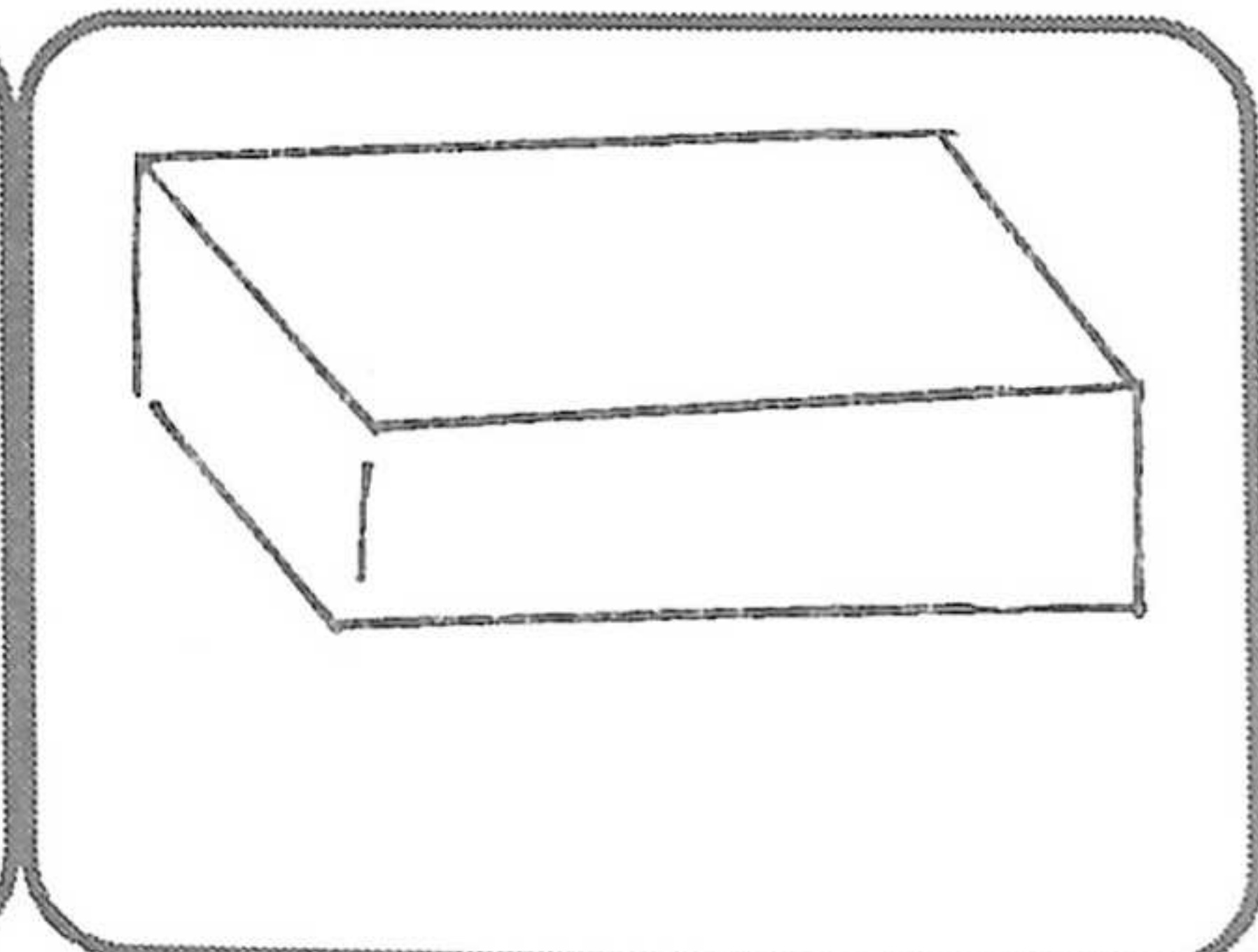

tzakon xan

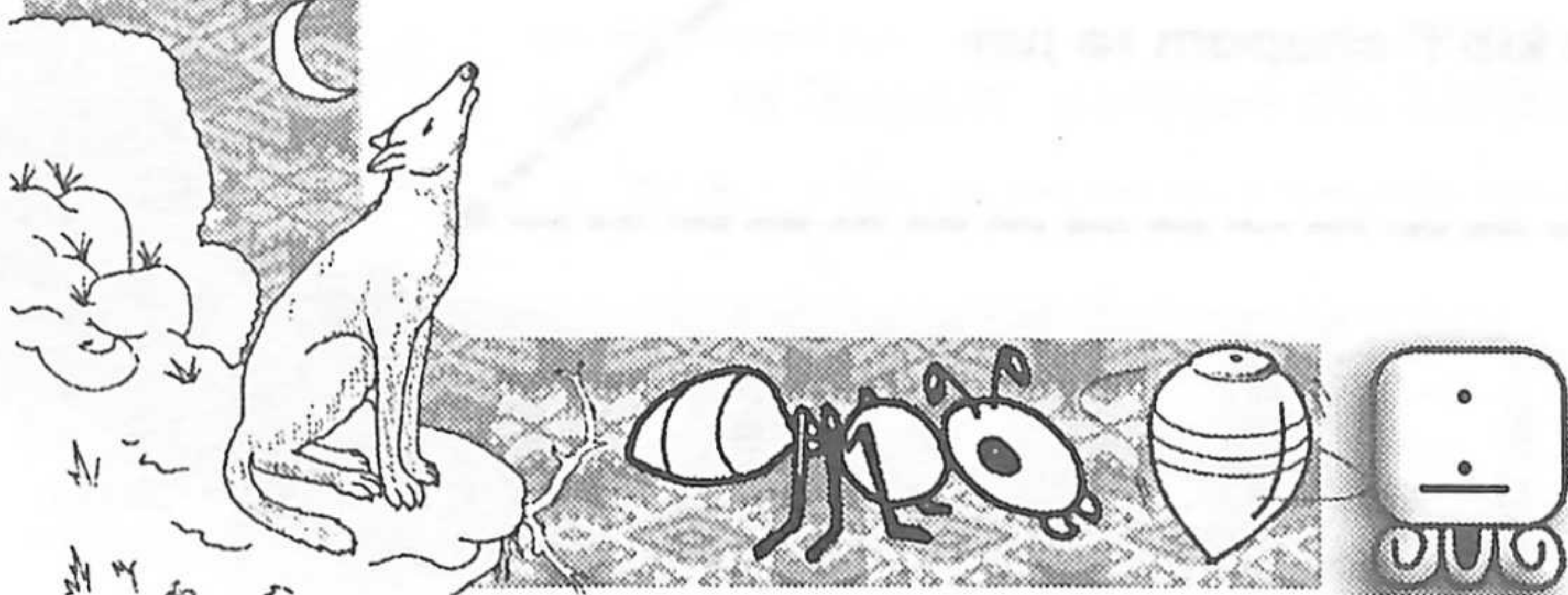

# Kochoch ri winaqi', chuqa' kochoch ri chikopi':

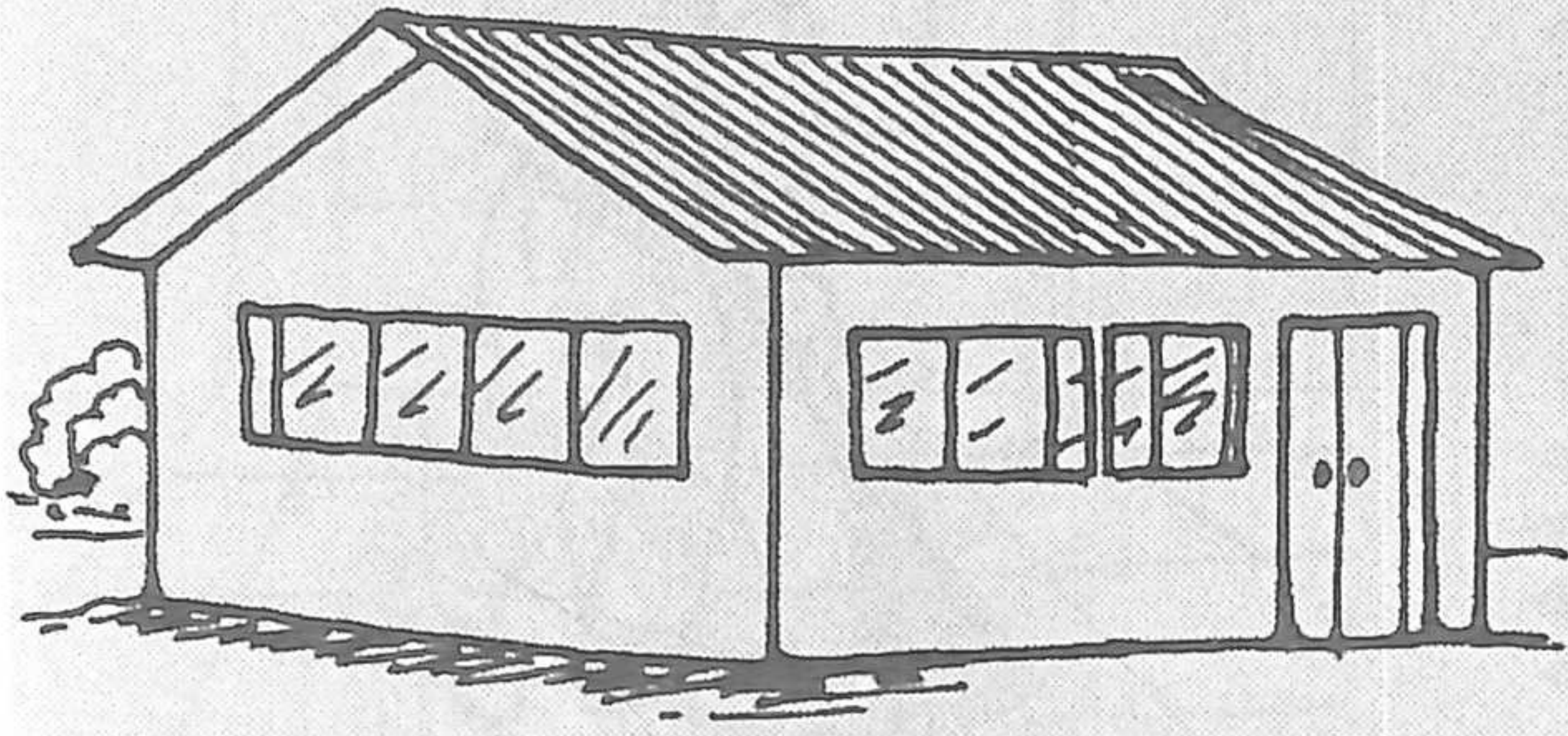

Rochoch jun winäq

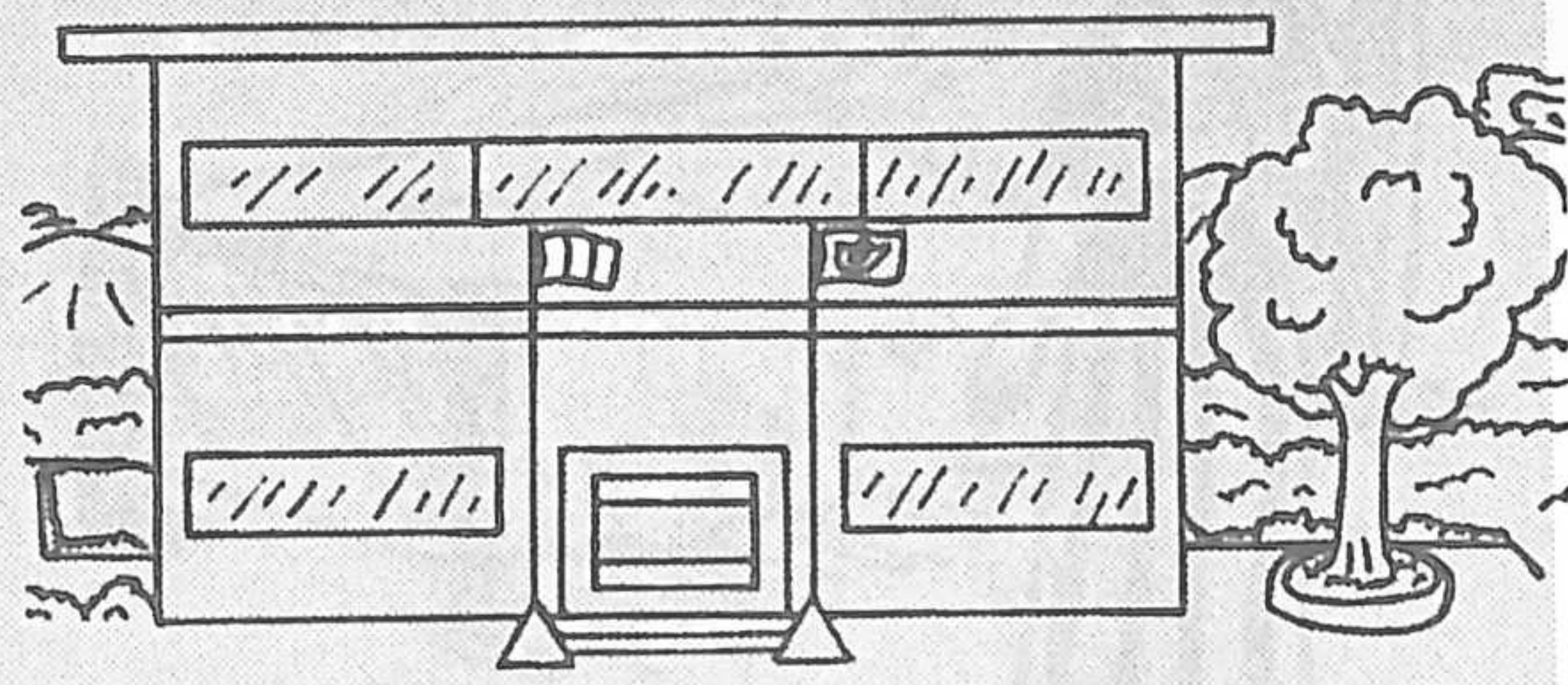

Kochoch ri tijoxela'

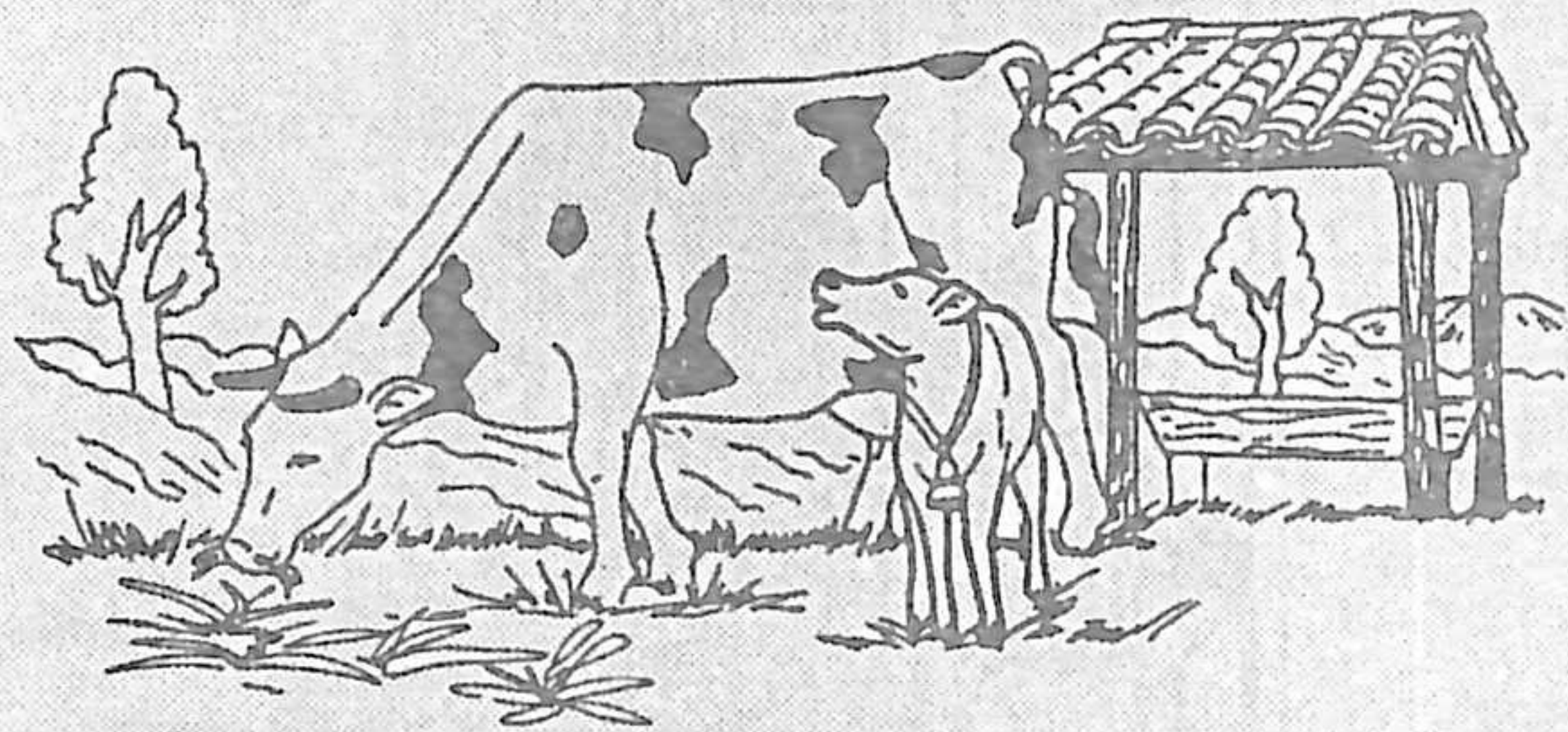

Kochoch jun wakx

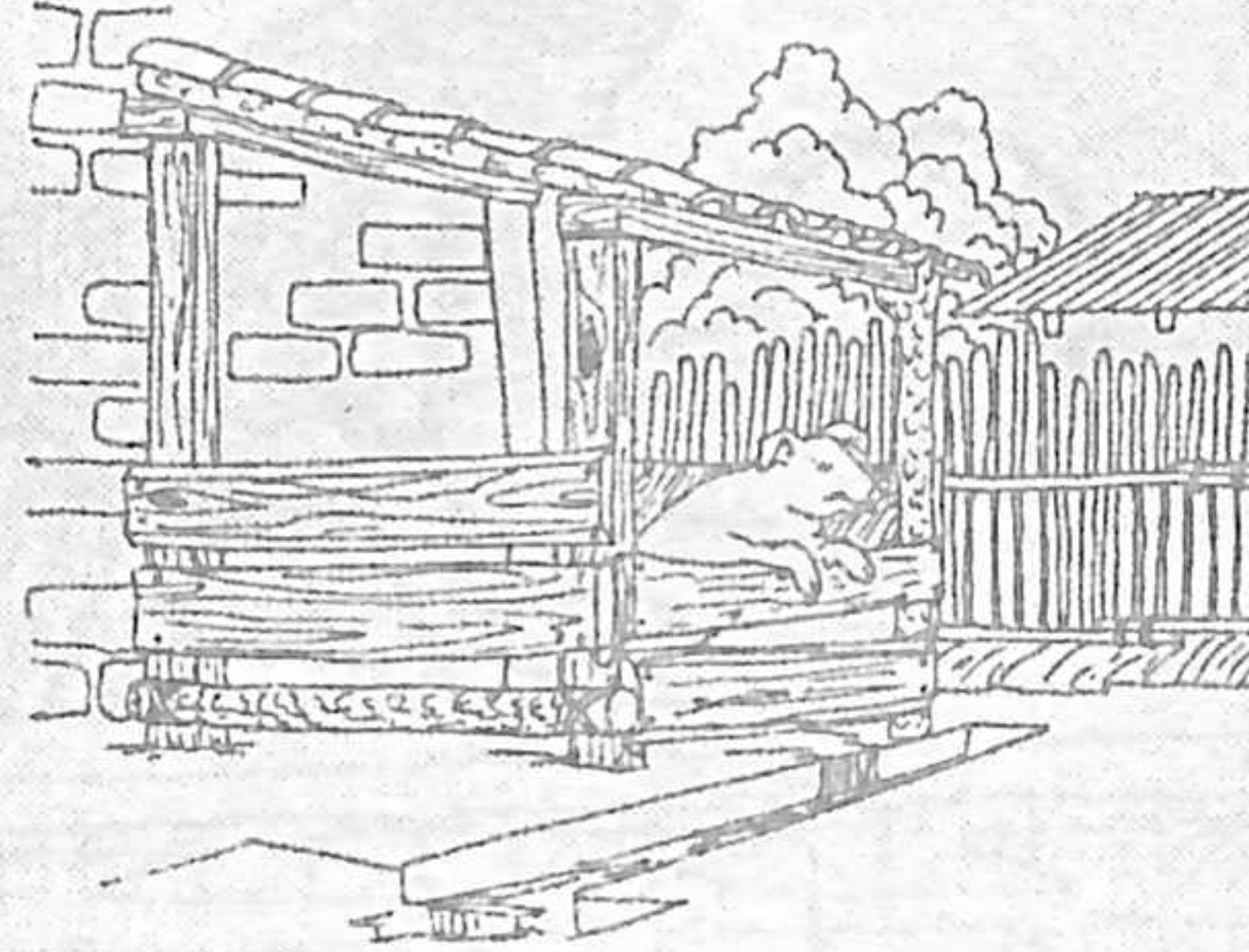

Rochoch jun aq

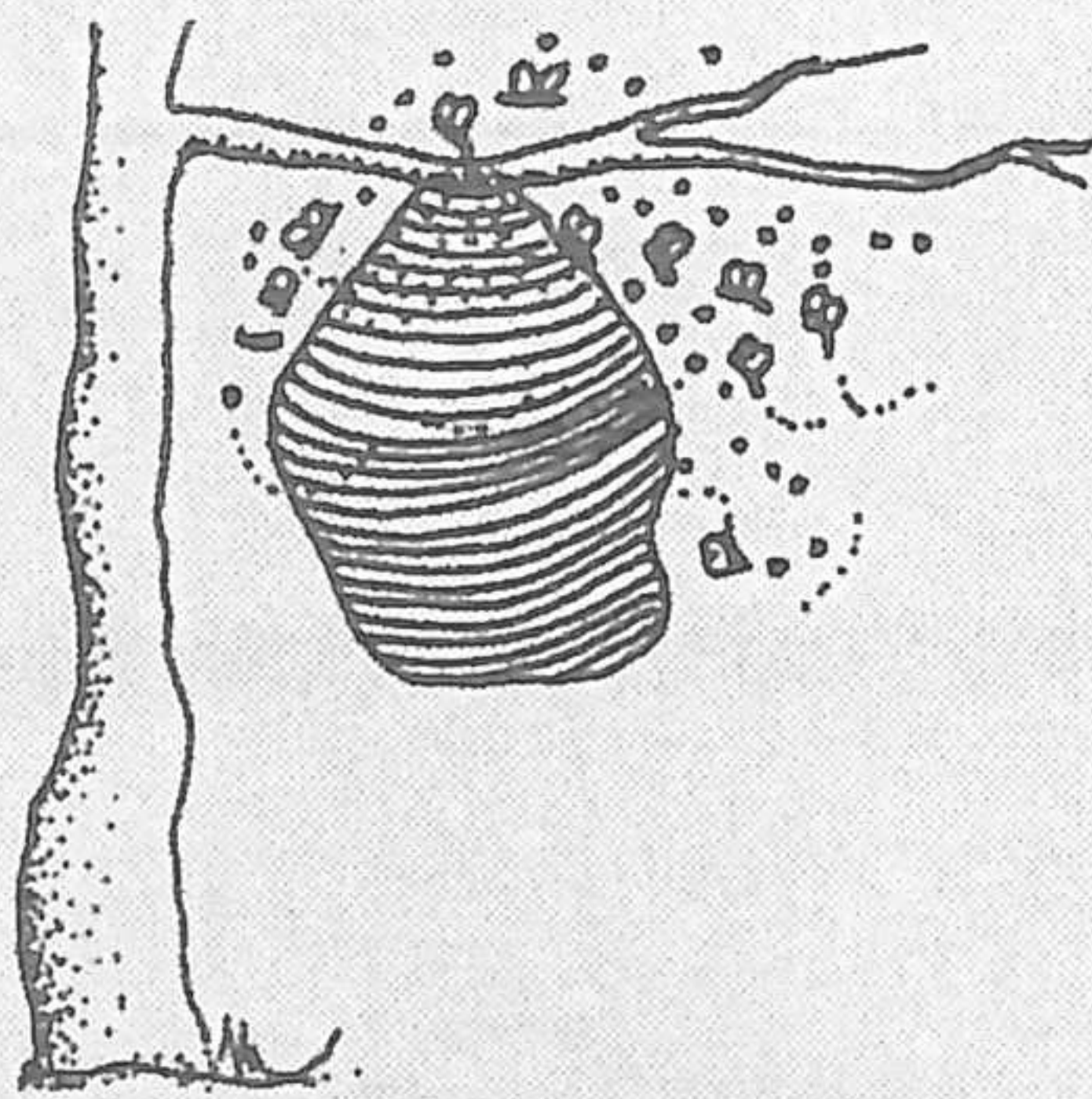

Kochoch aqaj

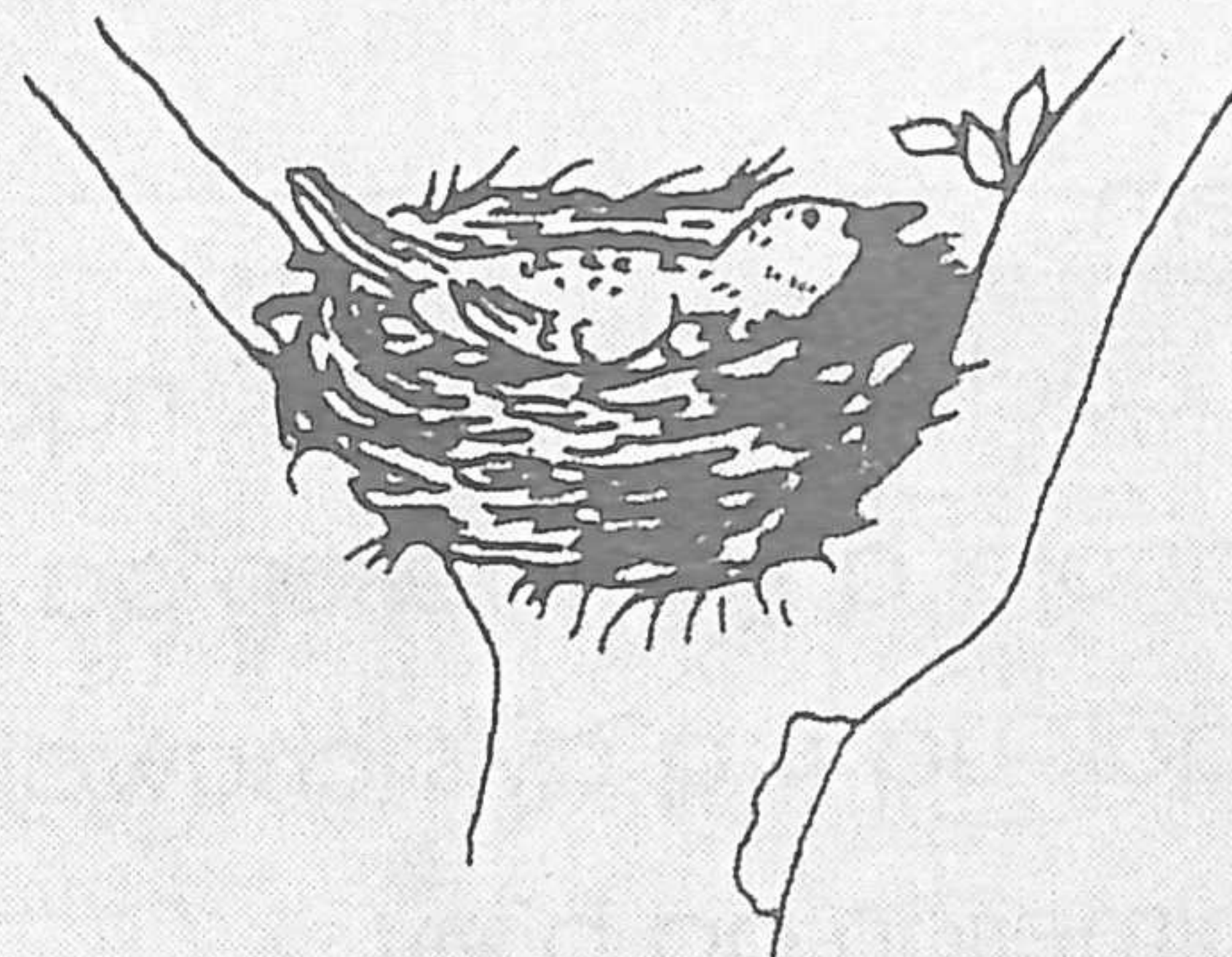

Rusok jun ti tz'ikin'

Ri tijonel nuk'ut chi kiwäch ri ak'wala' ri jalajöj taq kochoch ri winaqi', chuqa' kochoch ri chikopi'.  
Soloj samaj: Ri tijonel nub'ij chi ke ri tijoxela' chi nkib'onij, ri jalajöj taq achib'al.

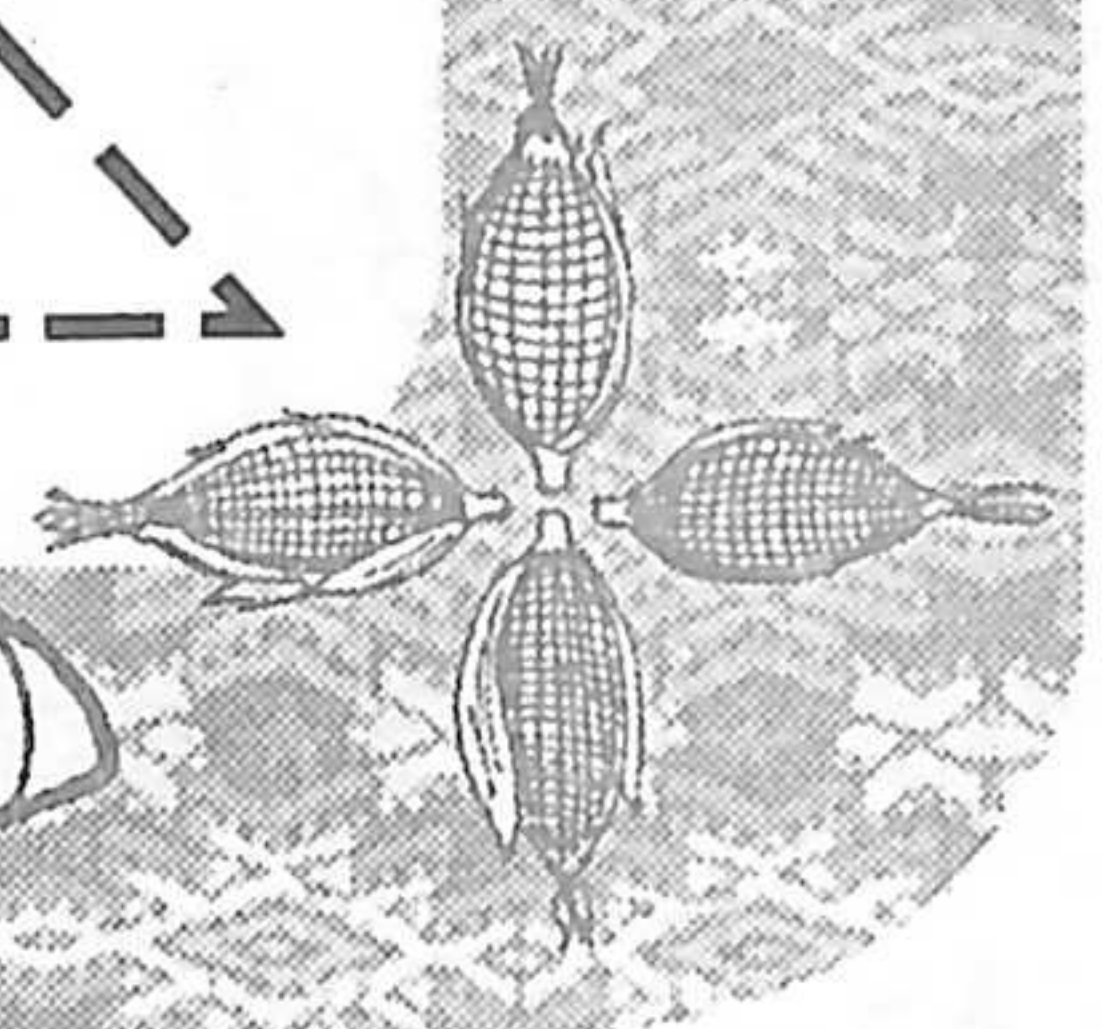
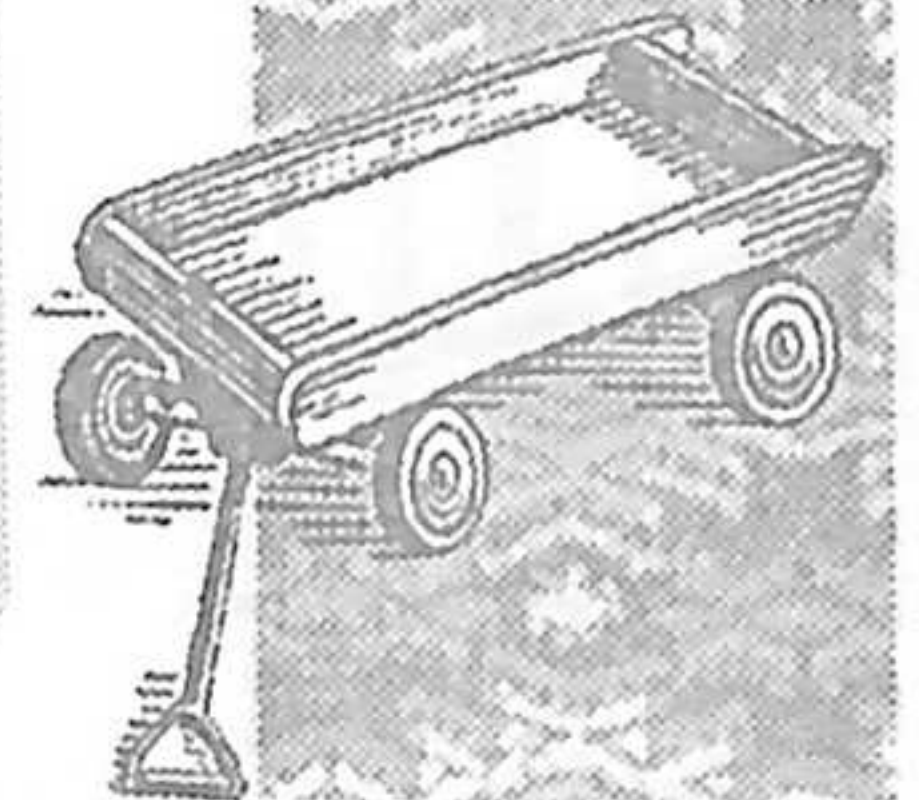
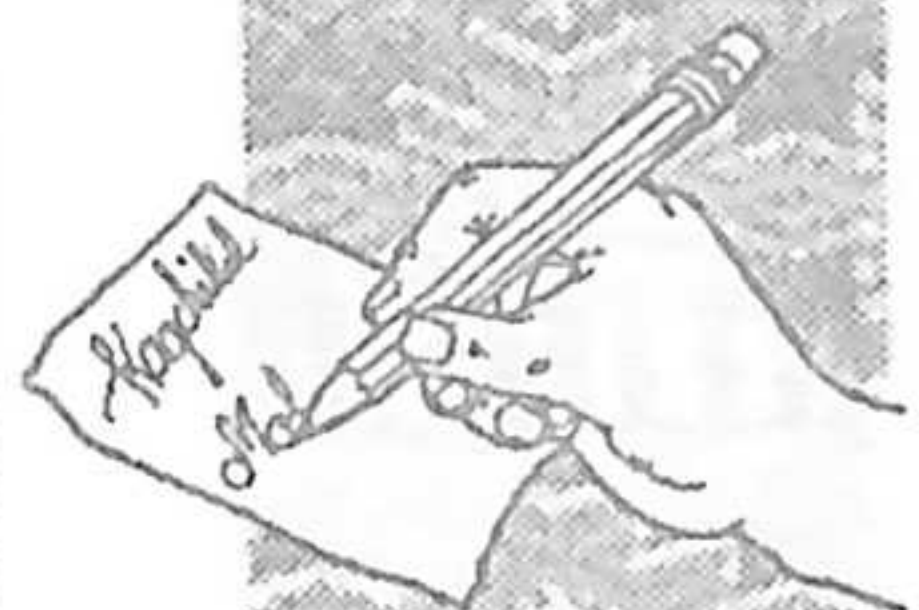

# RUJOSQ'IXIK RI QOCHOCH

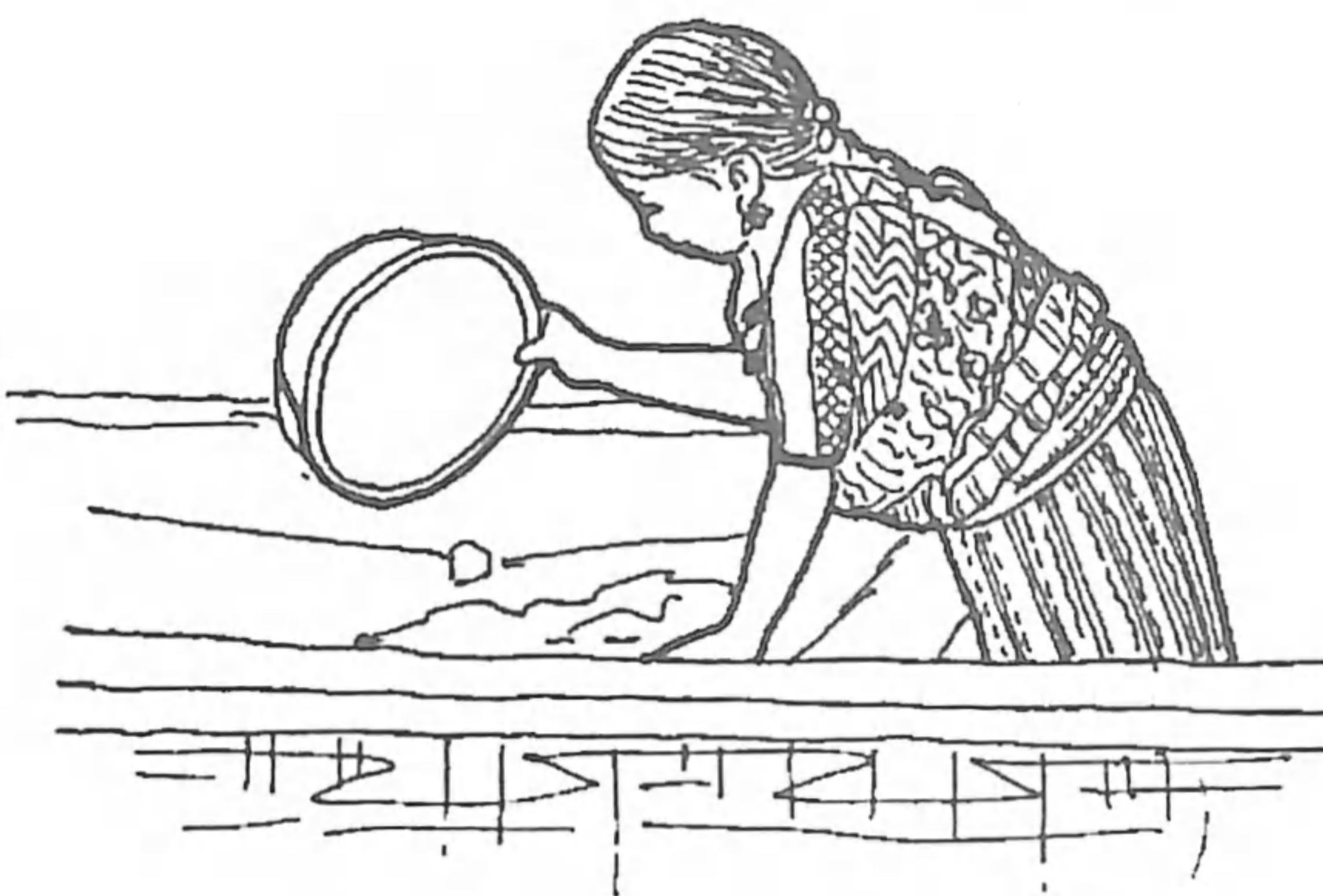
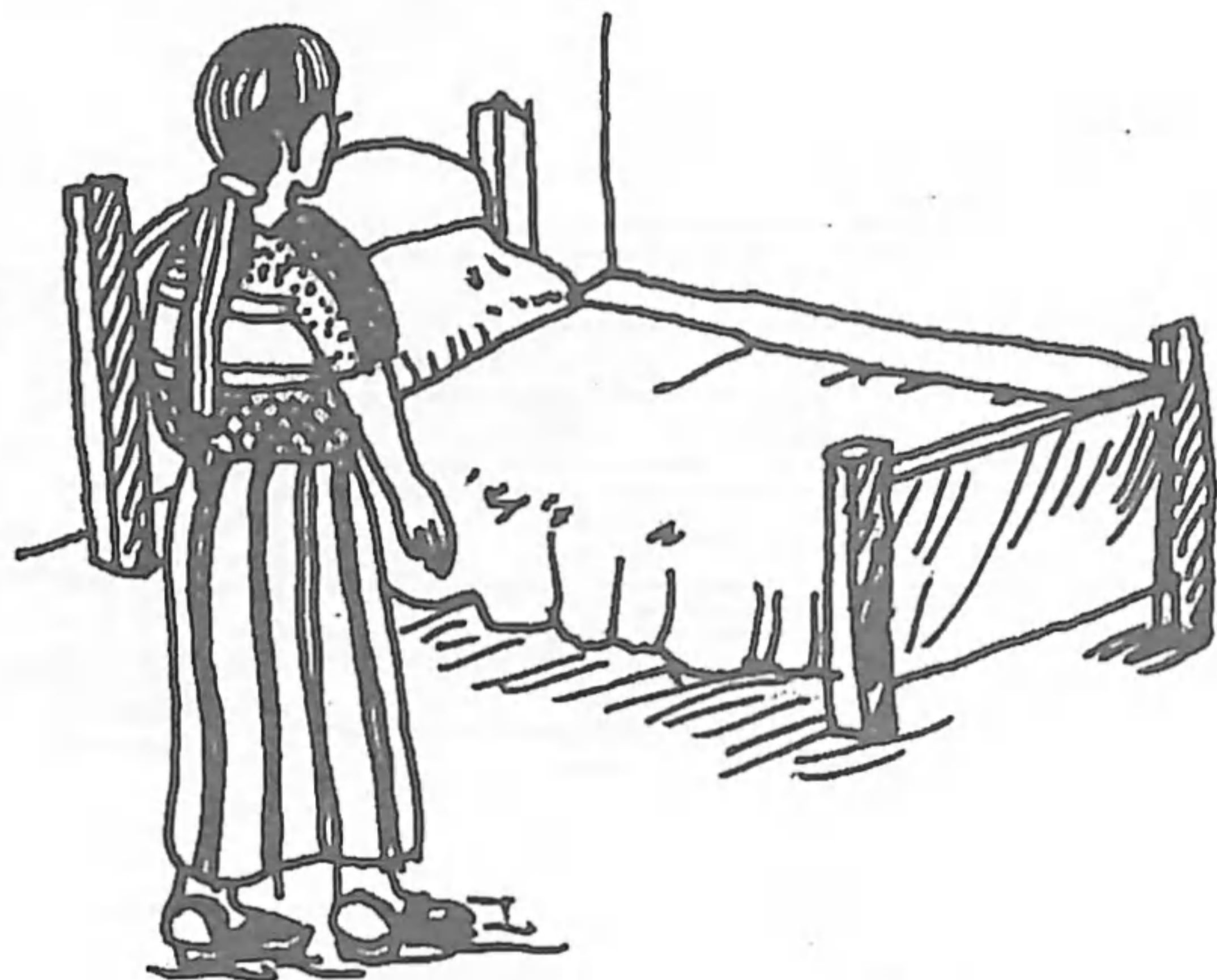

Tzijonem:

Ri qochoch jantape' nqajosaq'ij.  
 Ronojel q'ij yojmeson pa jay.  
 Nqak' uq ri q' ayis chuwajay.  
 Yojmeson pa b'ey.  
 Yojmeson chuwajay.  
 Ch'ajch'öj ri qochoch.

Tqach'ob'o' ri jujun achib'äl, k'a ri tqab'ij ri samaj nkib'än.  
 Solojsamaj: Ri tijoxela' nkib'ij achike samaj nkib'än ri winaqi' e k'o pa taq achib'äl.

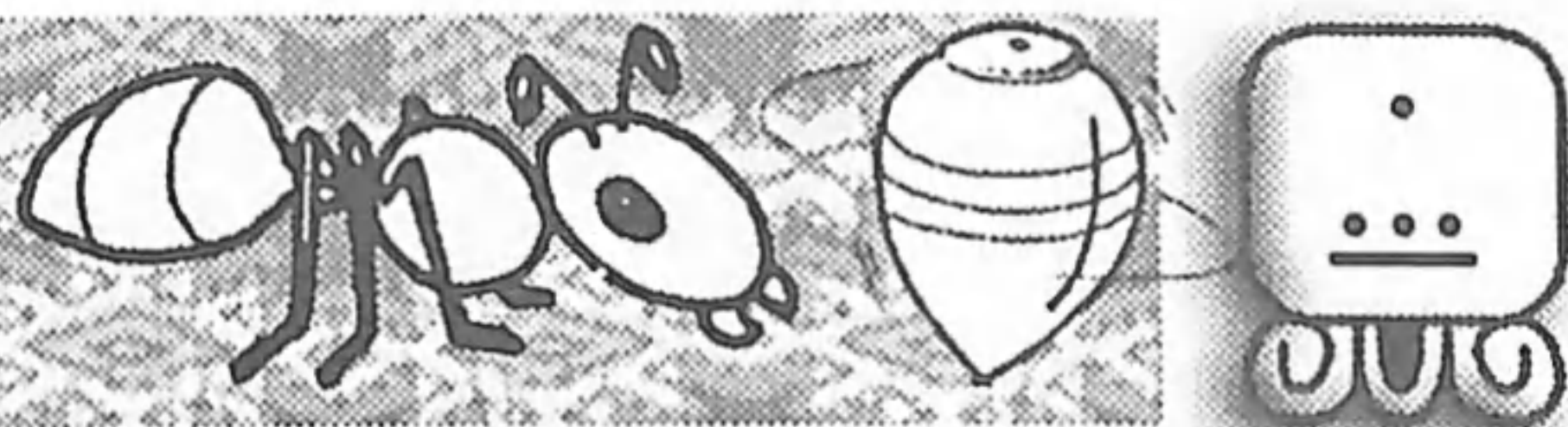

# Solojsamaj

Keqatz'eta' akuchi e k'o wi re winaqi' chuqa' ri chiköp.



¿Akuchi k'o wi re jun achin re'?

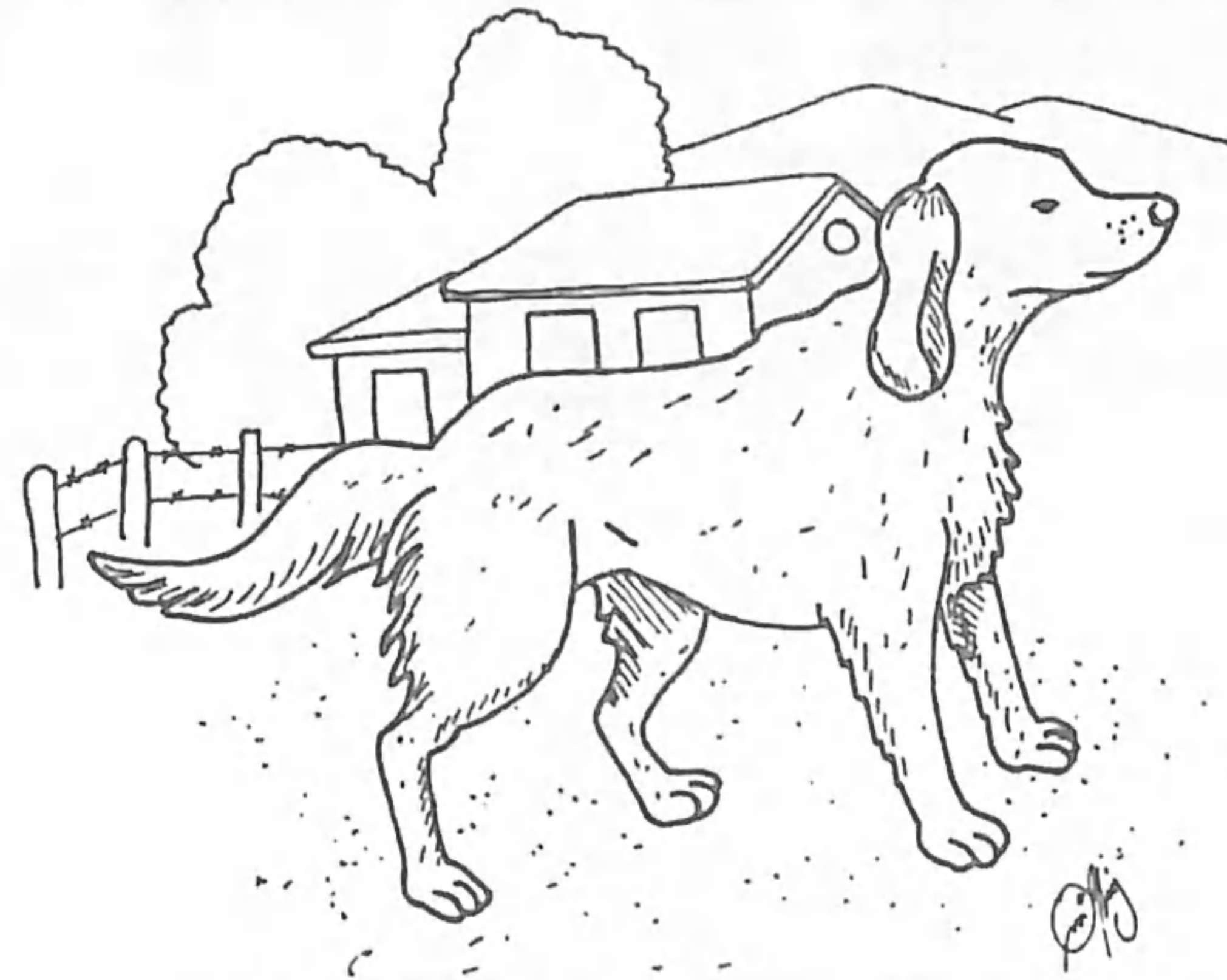

¿Akuchi k'o wi re tz'i' re'?

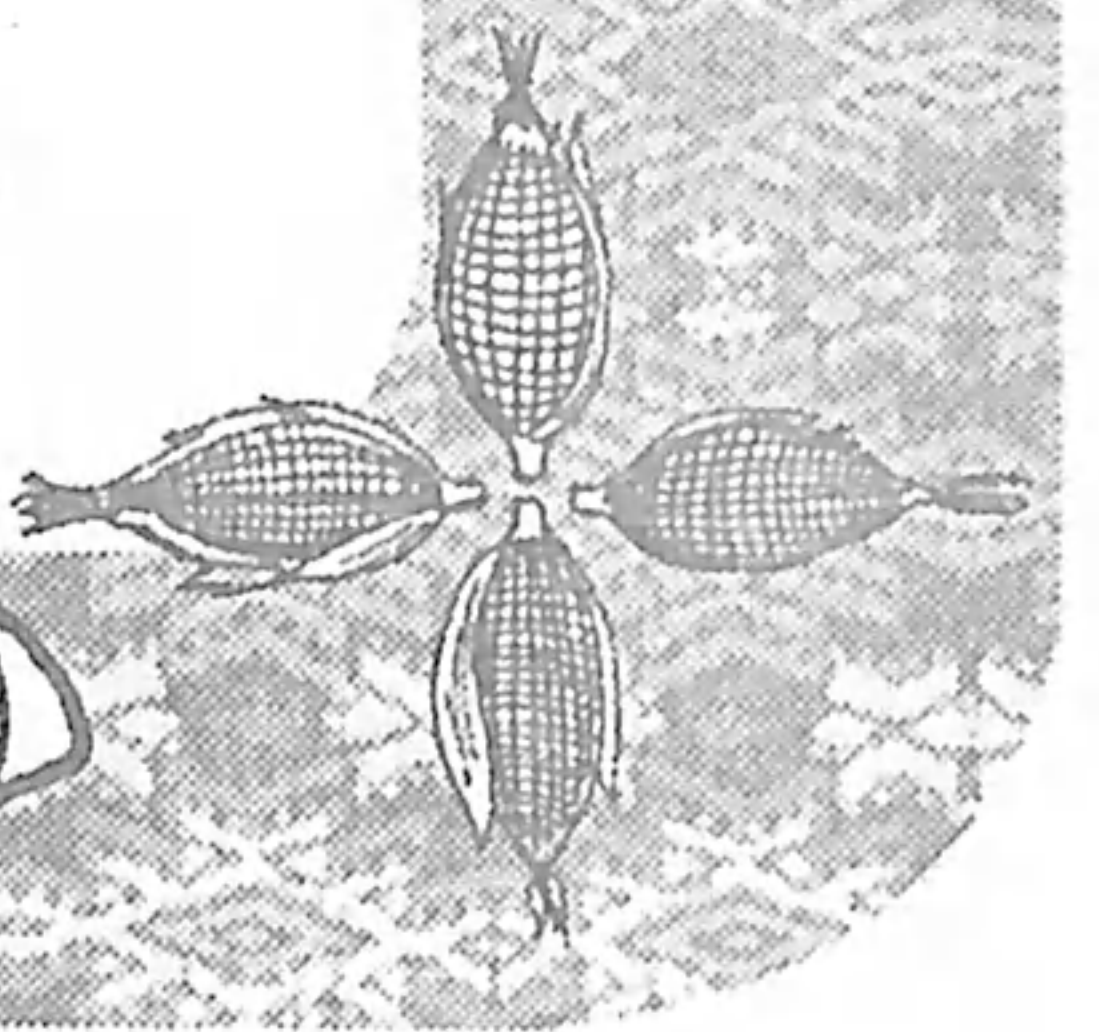
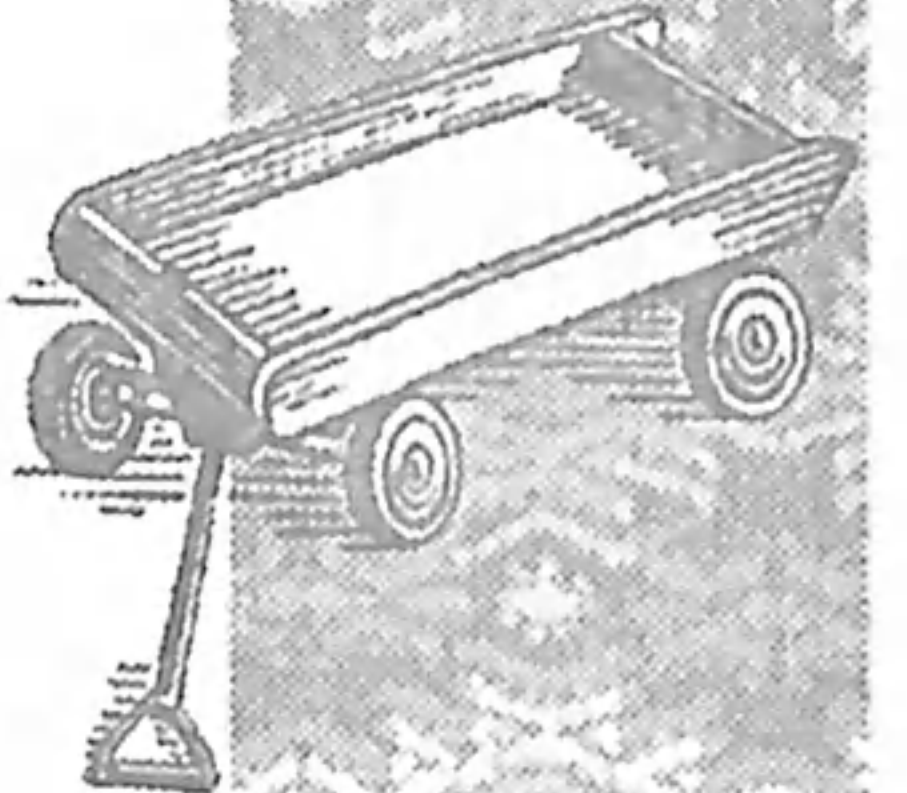
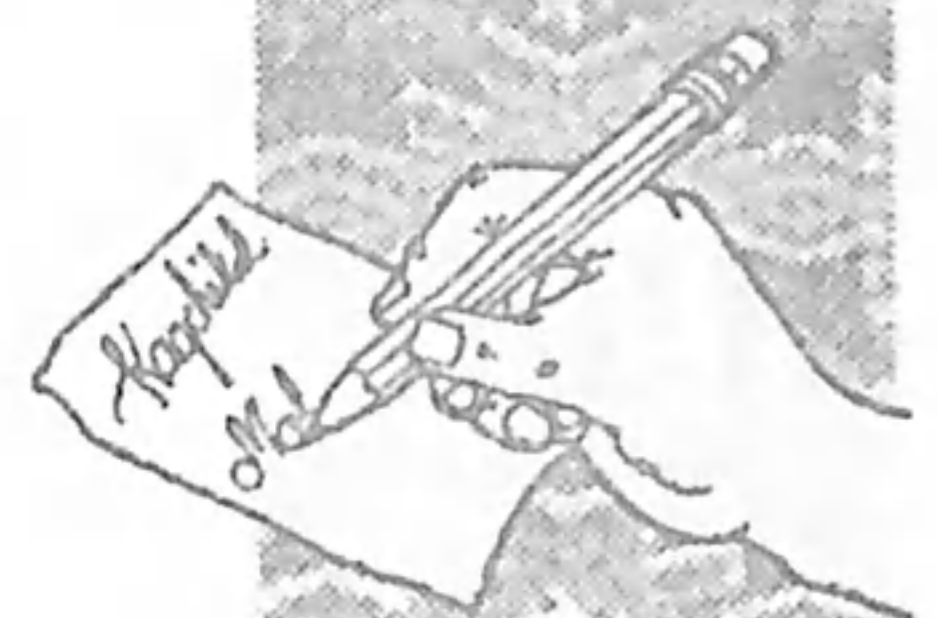

¿Akuchi nwa' re jun k'ajol re'?

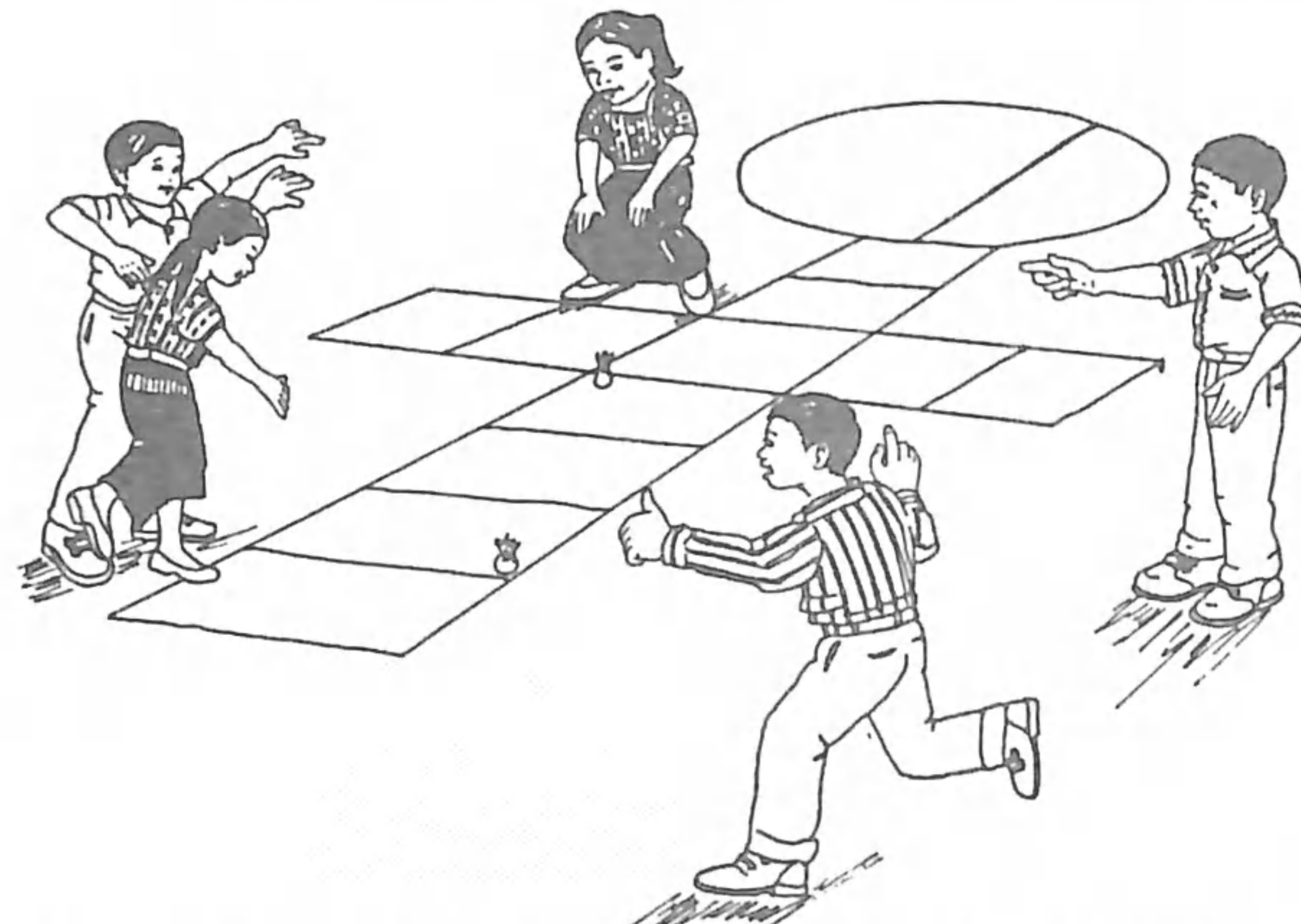

¿Akuchi ye'etz'an wi re jujun ak'wala'?



¿Akuchi natin wi ri ak'wal?



¿Akuchi nwär wi ri ala'?



Nqatz'ib'aj kib'i' re achib'äl re'.

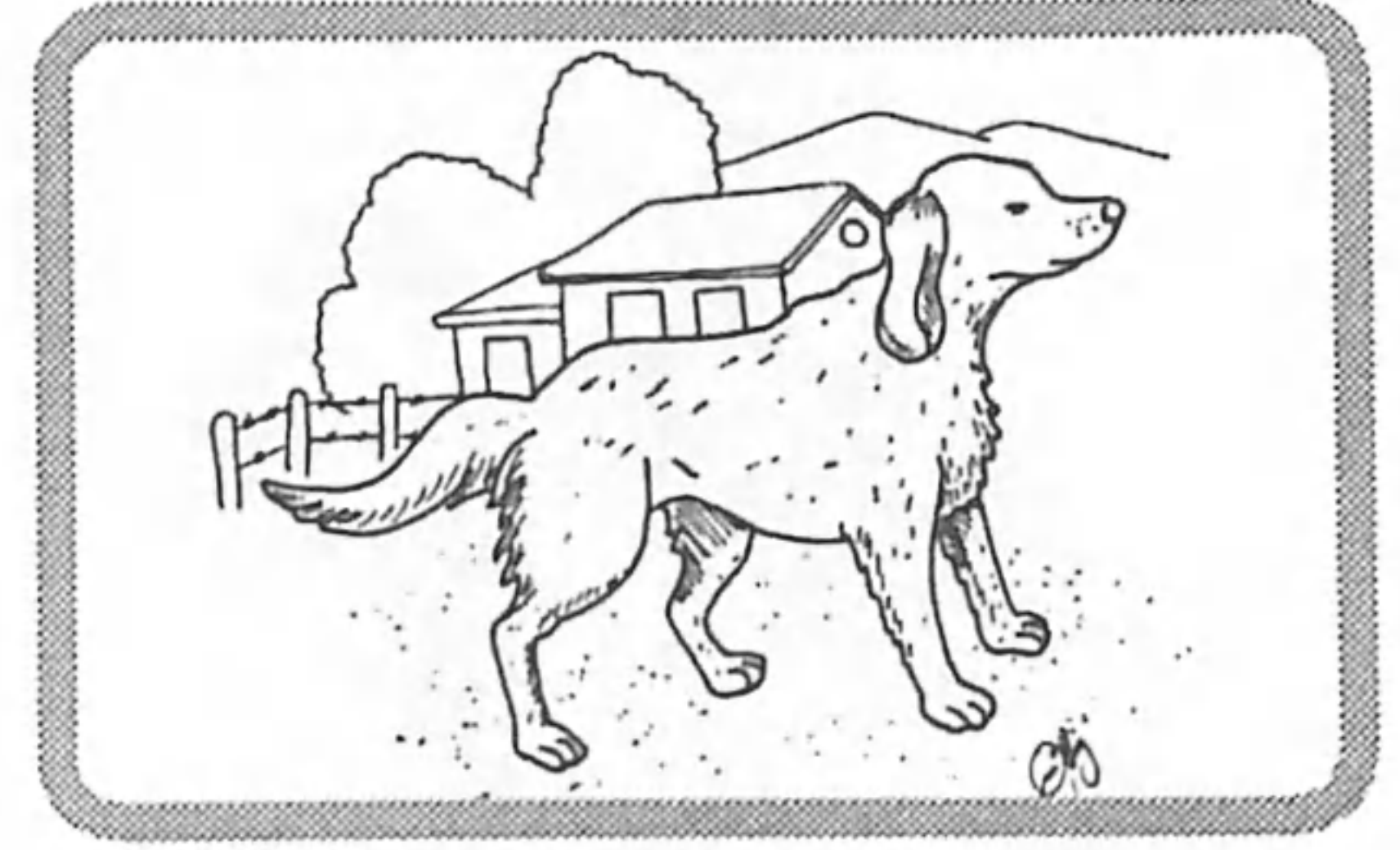
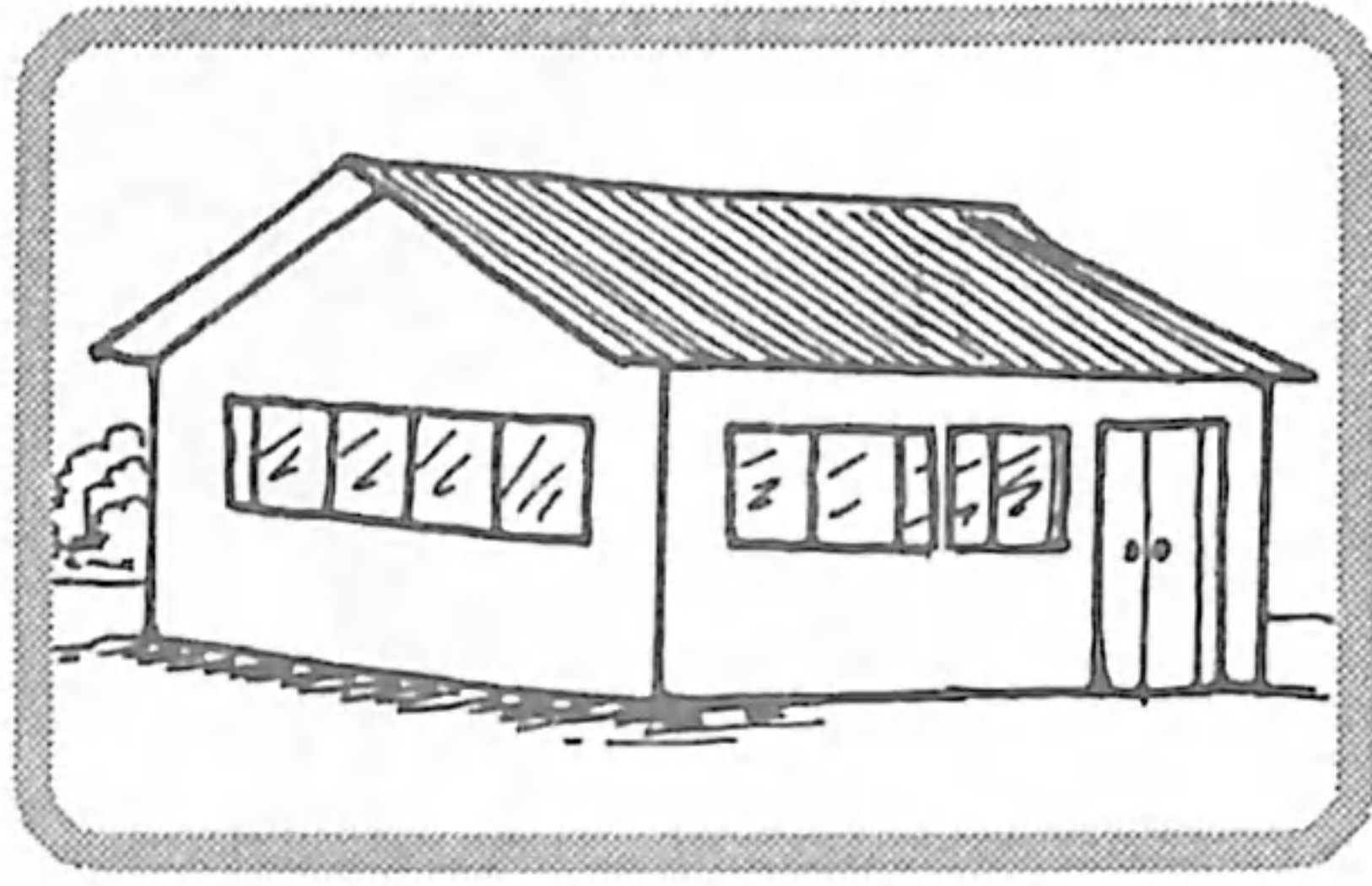

\_\_\_\_\_

\_\_\_\_\_

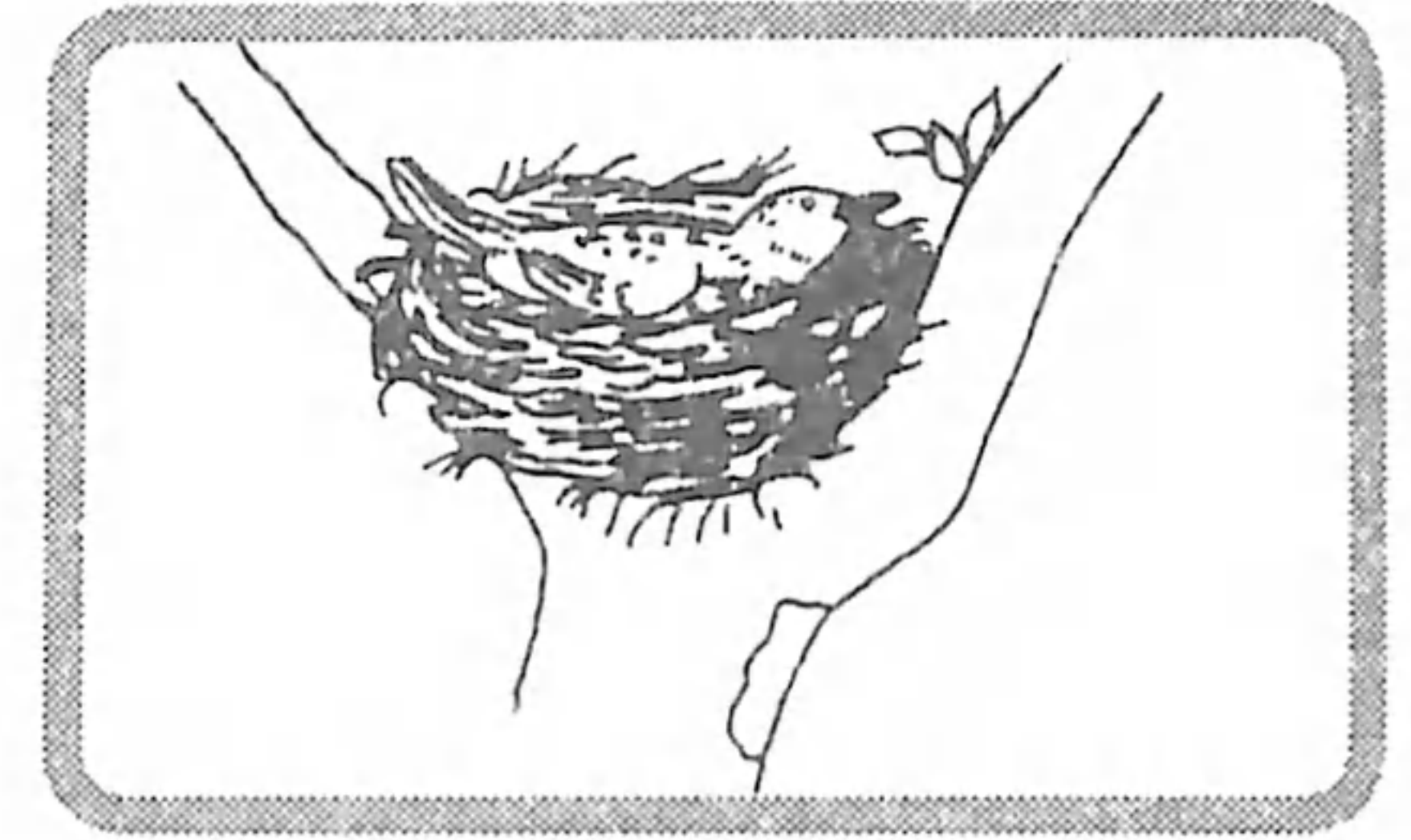

\_\_\_\_\_

\_\_\_\_\_

Nqatz'ib'aj akuchi e k'o wi re winaqi' re':

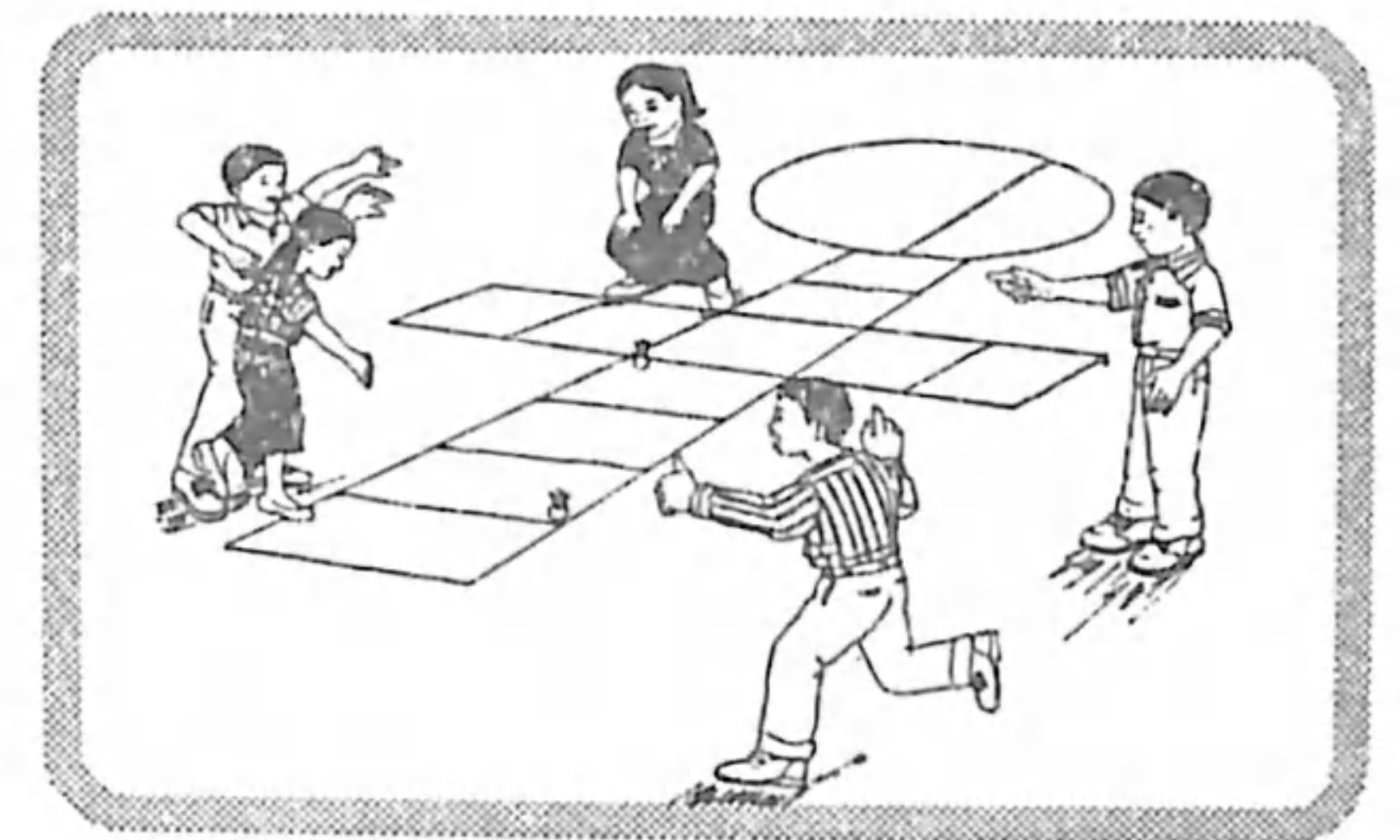

Akuchi nwa' re jun ak'wal re'.

Akuchi ye'etz'an wi re ak'wala'

\_\_\_\_\_

\_\_\_\_\_

Ri tijoxela' yetz'ib'an pa ruwi' ri faq juch'.

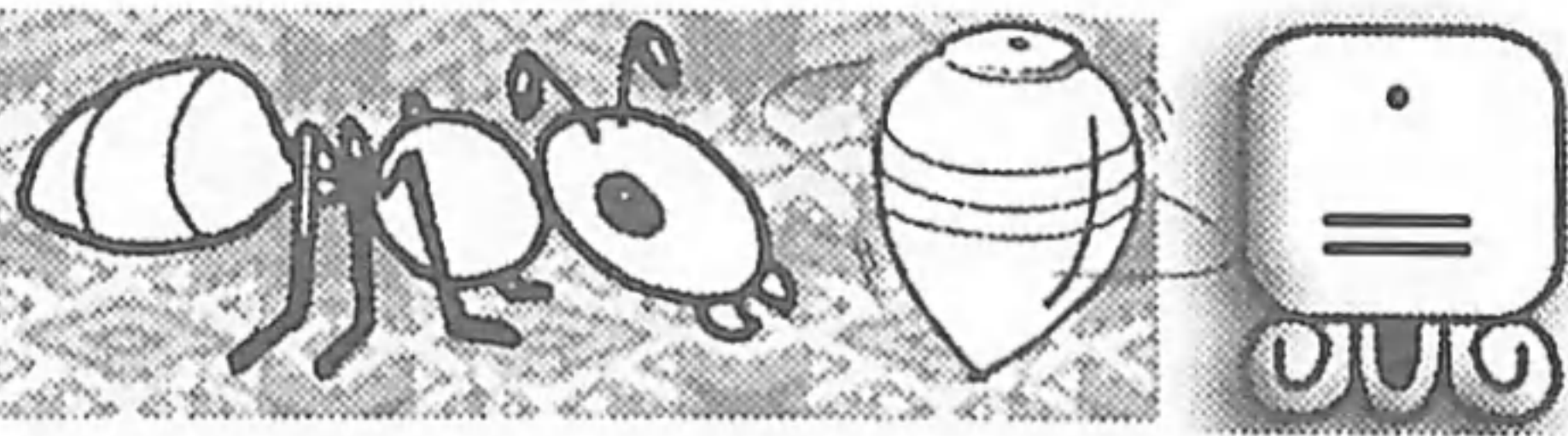
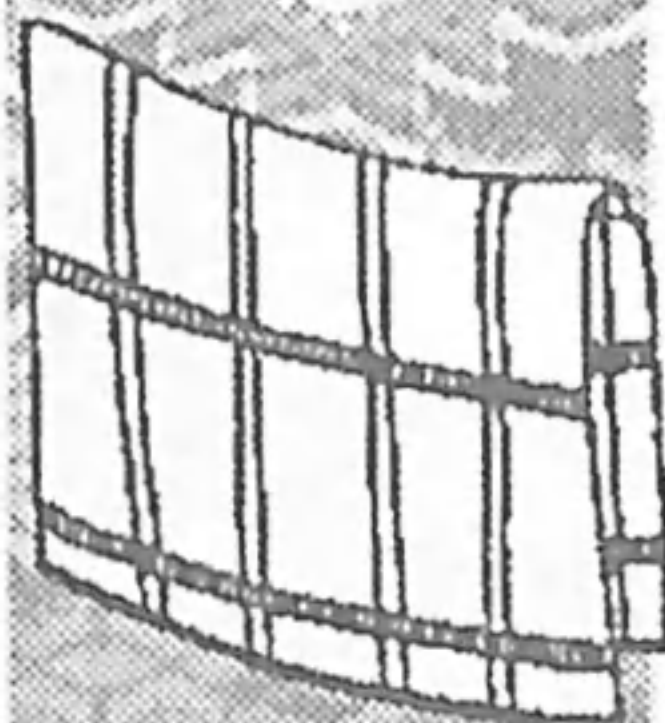

# ROX TANAJ

Qatinamit.



Ri etamanik nuq'i' ri tijoxel:

Nuch'ob' ri rejqalem rutinamit.  
Nuch'ob' ri samaj nkib'an ri winaqi'.  
Retaman achike runuk'ik rub'anon.

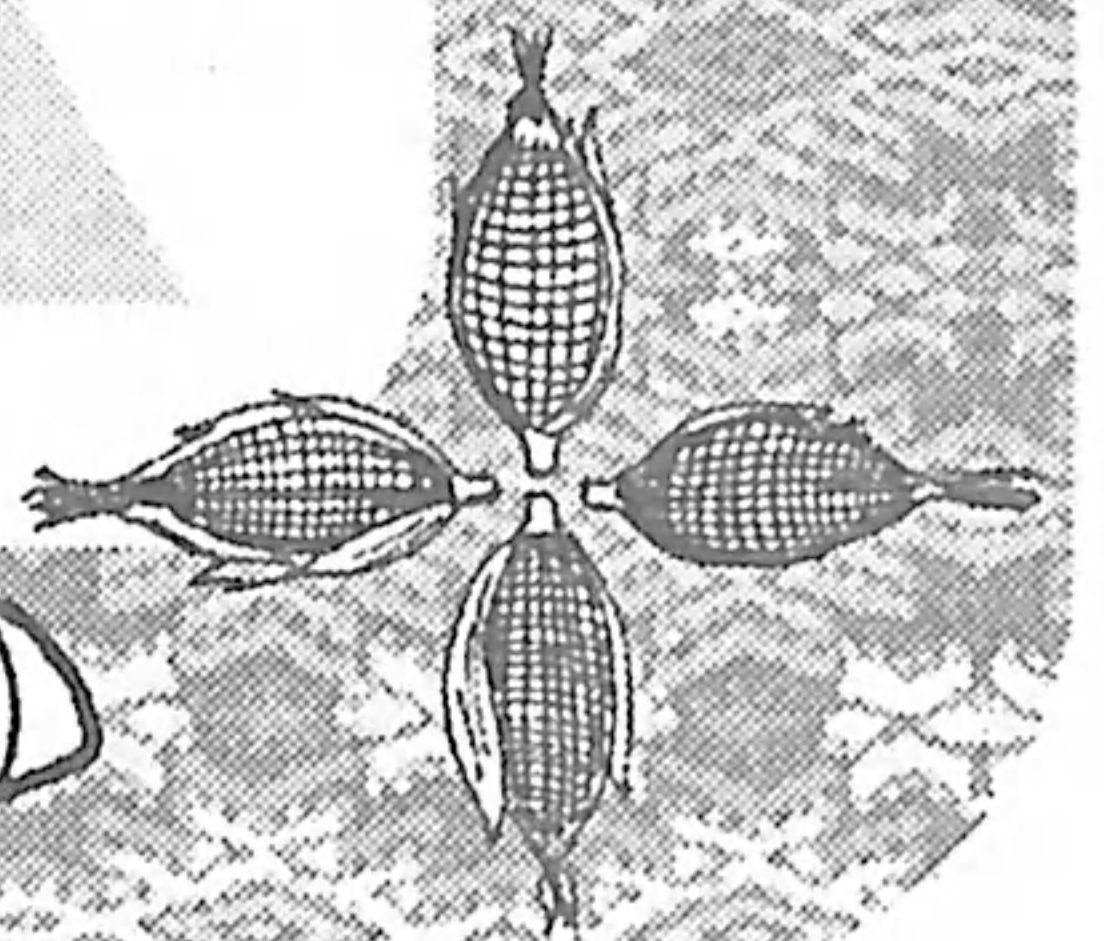
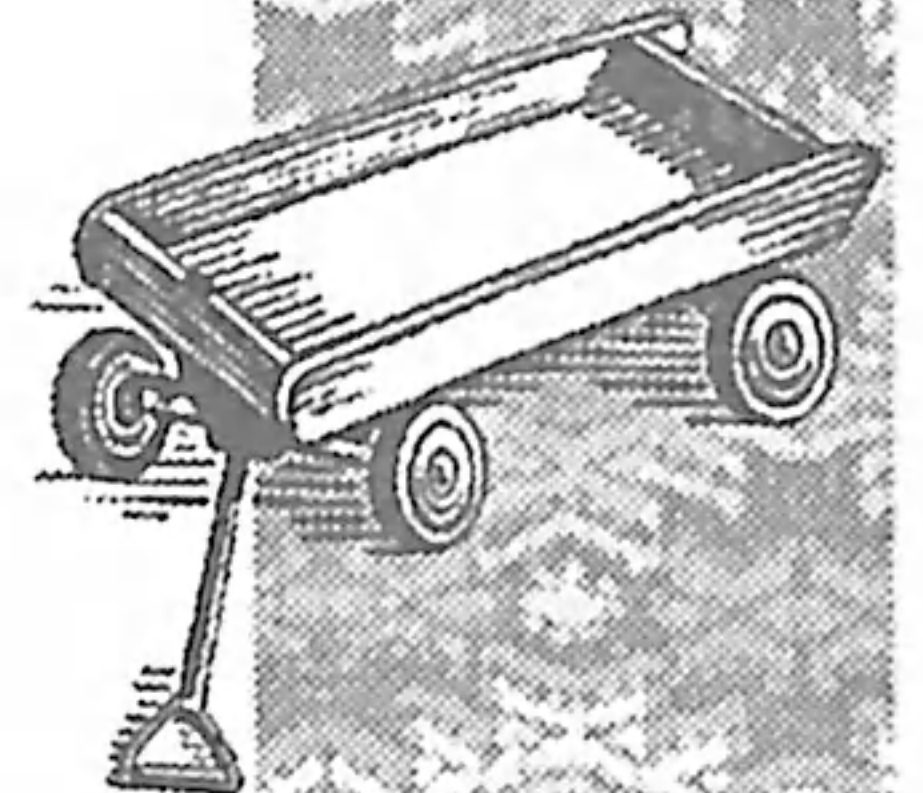
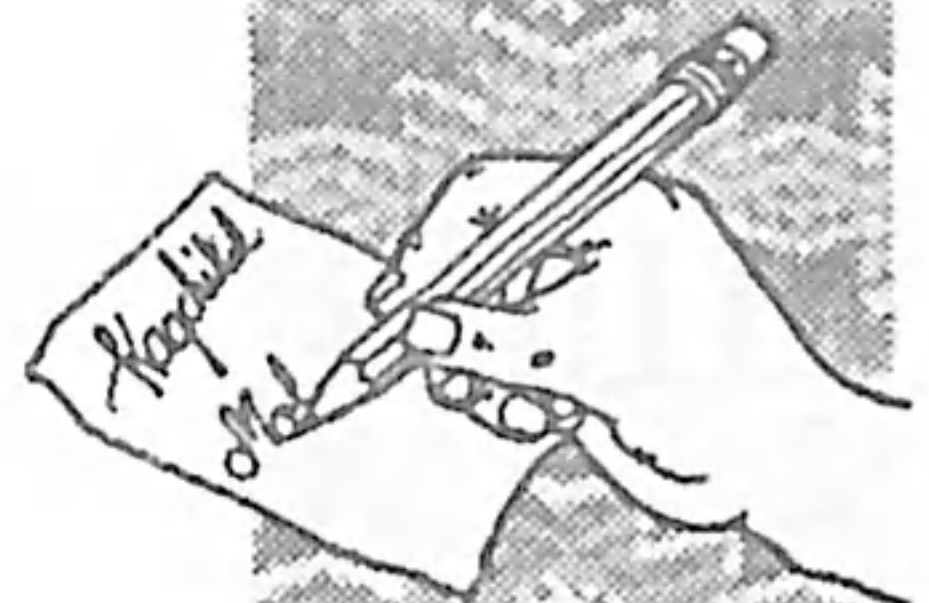
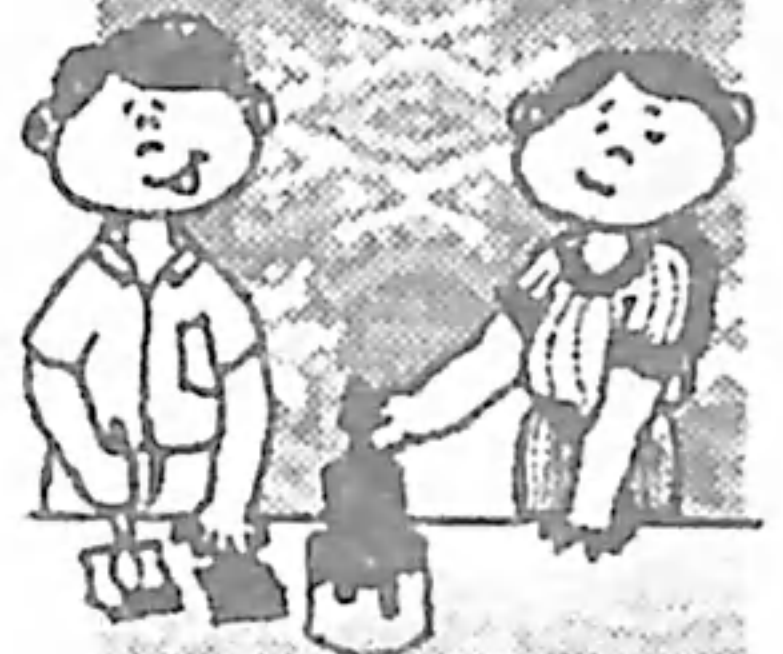



# RI QATINAMIT



Ri Xinwetamal

Pa taq molaj tqab'ana' rachib'äl ri qatinamit k'a ri' kotzizon pa ruwi'. Kojch'ob'on chi rij ri samaj nikib'an ri winaqi'.

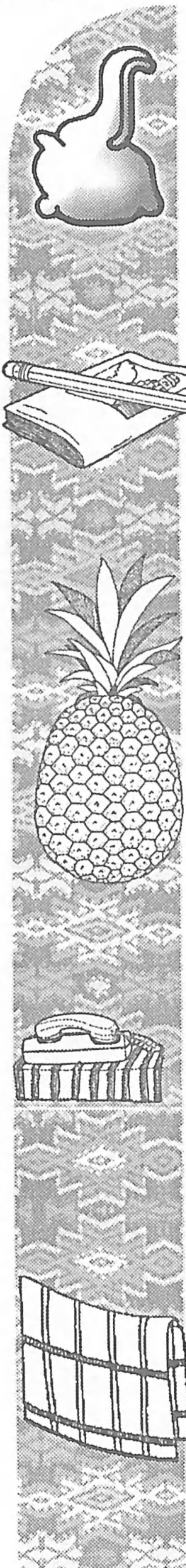
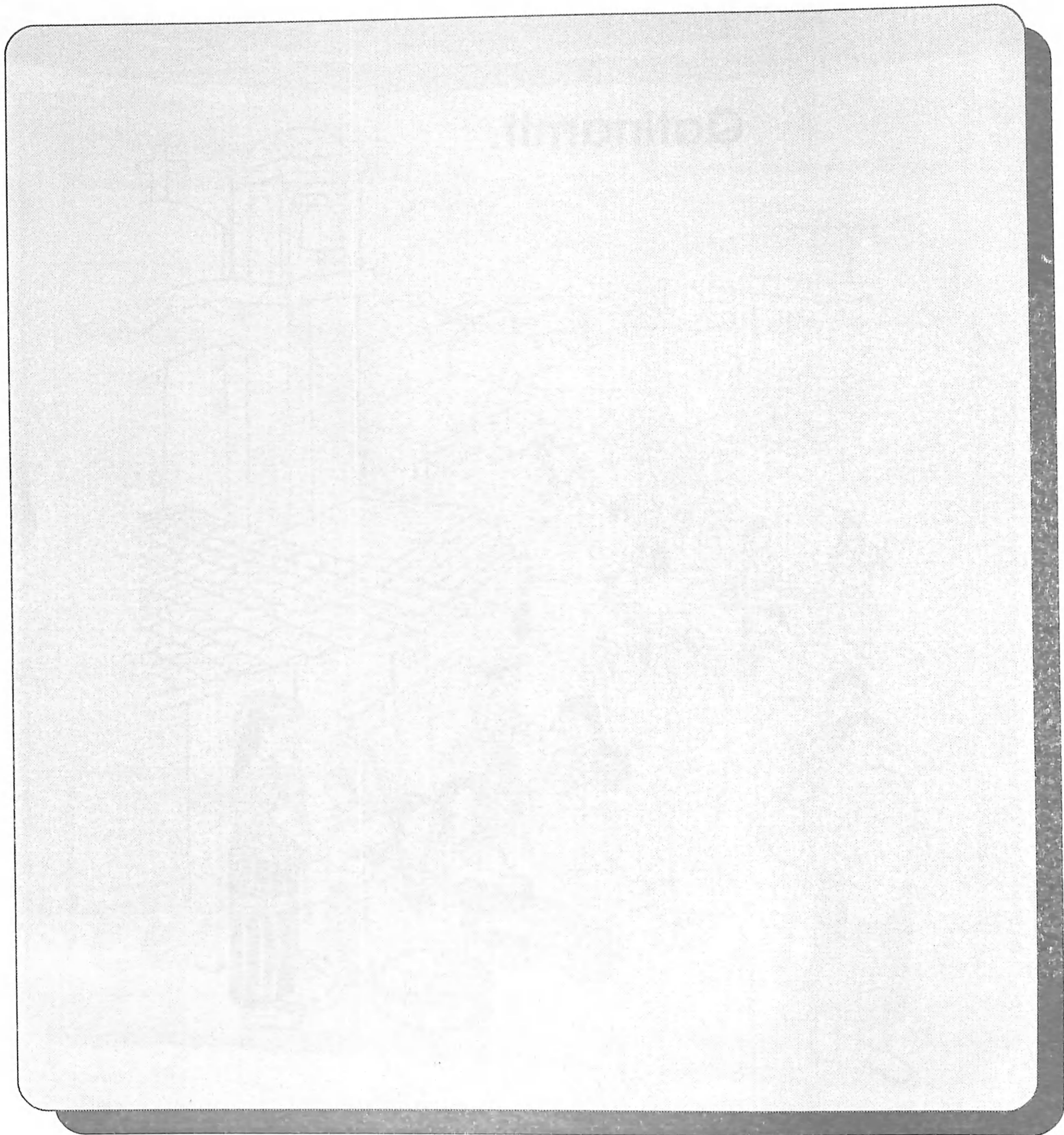

Ri tijonel nujäch chi kiwäch ri ak'wala' jalajöj taq achib'äl richin rije' pa taq molaj nikit'arab'a' chuwäch ri ruxaq wuj richin nkipab'a' rachib'äl jun finamit. Töq xkek'achoj tikikamuluj rub'ixik ri jujun achib'äl xkitz'arab'a'.



# RI RUNUK'IK RI QATINAMIT

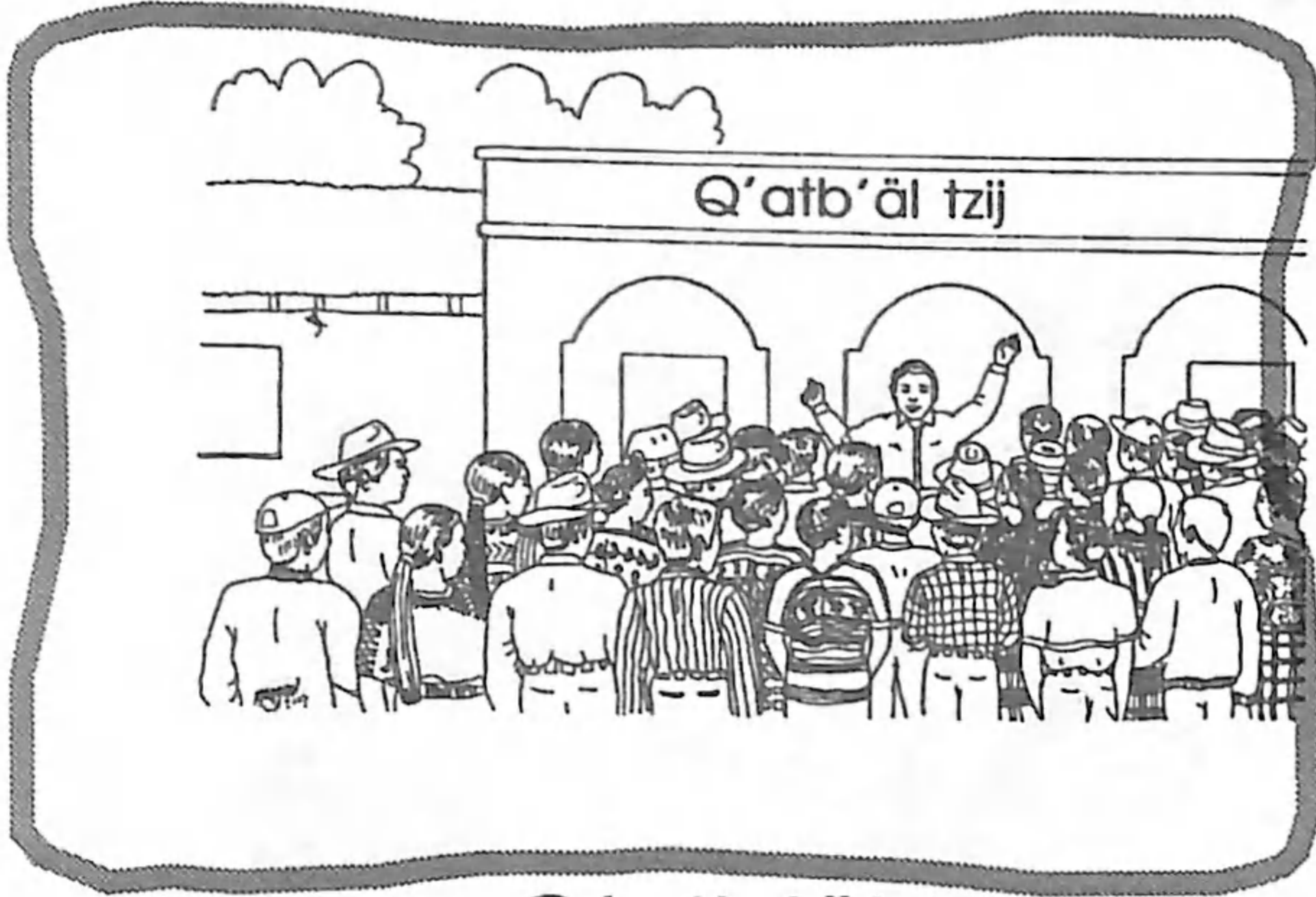

Q'atb'äl tzij

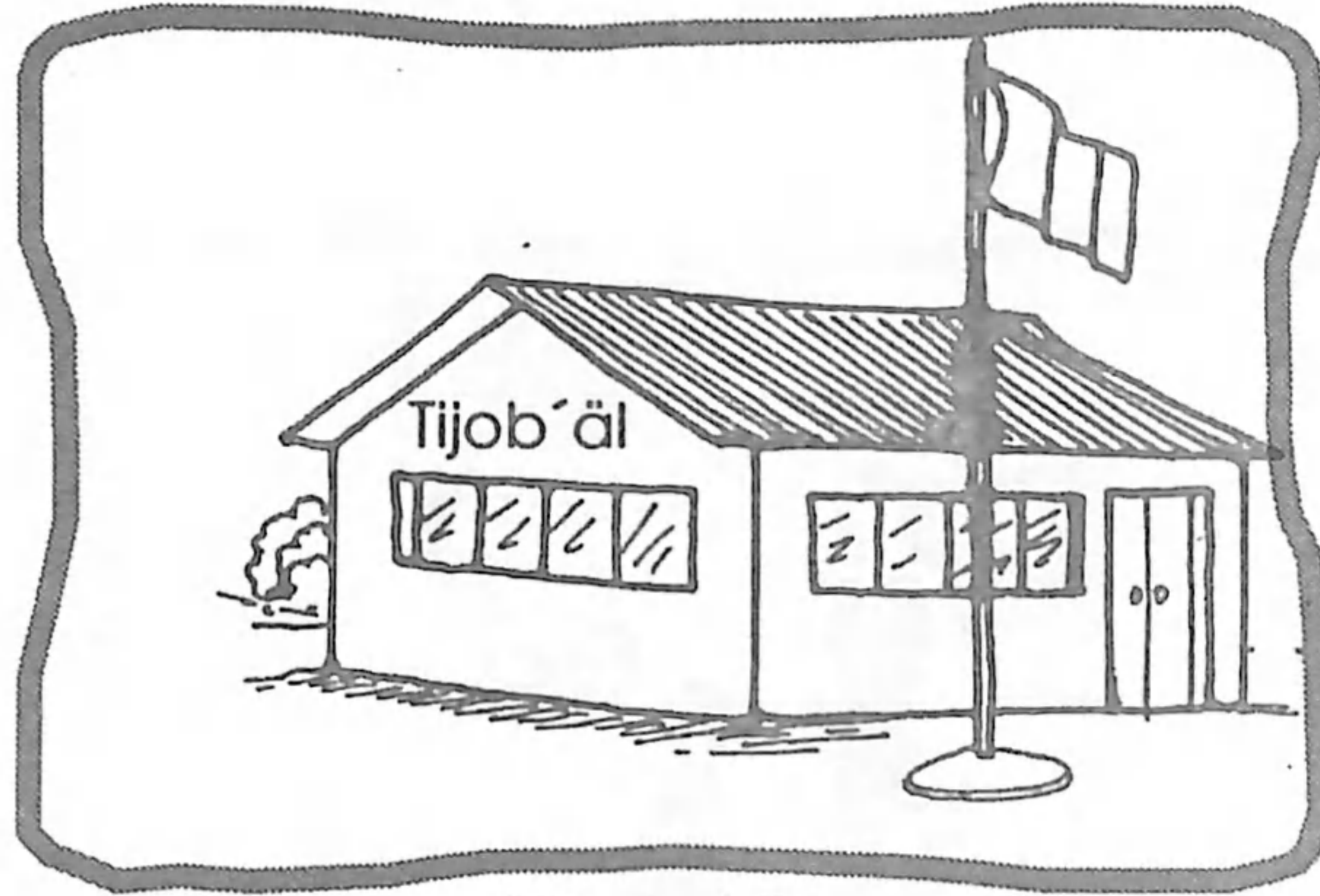

Tijob'äl



Aq'omab'äl jay

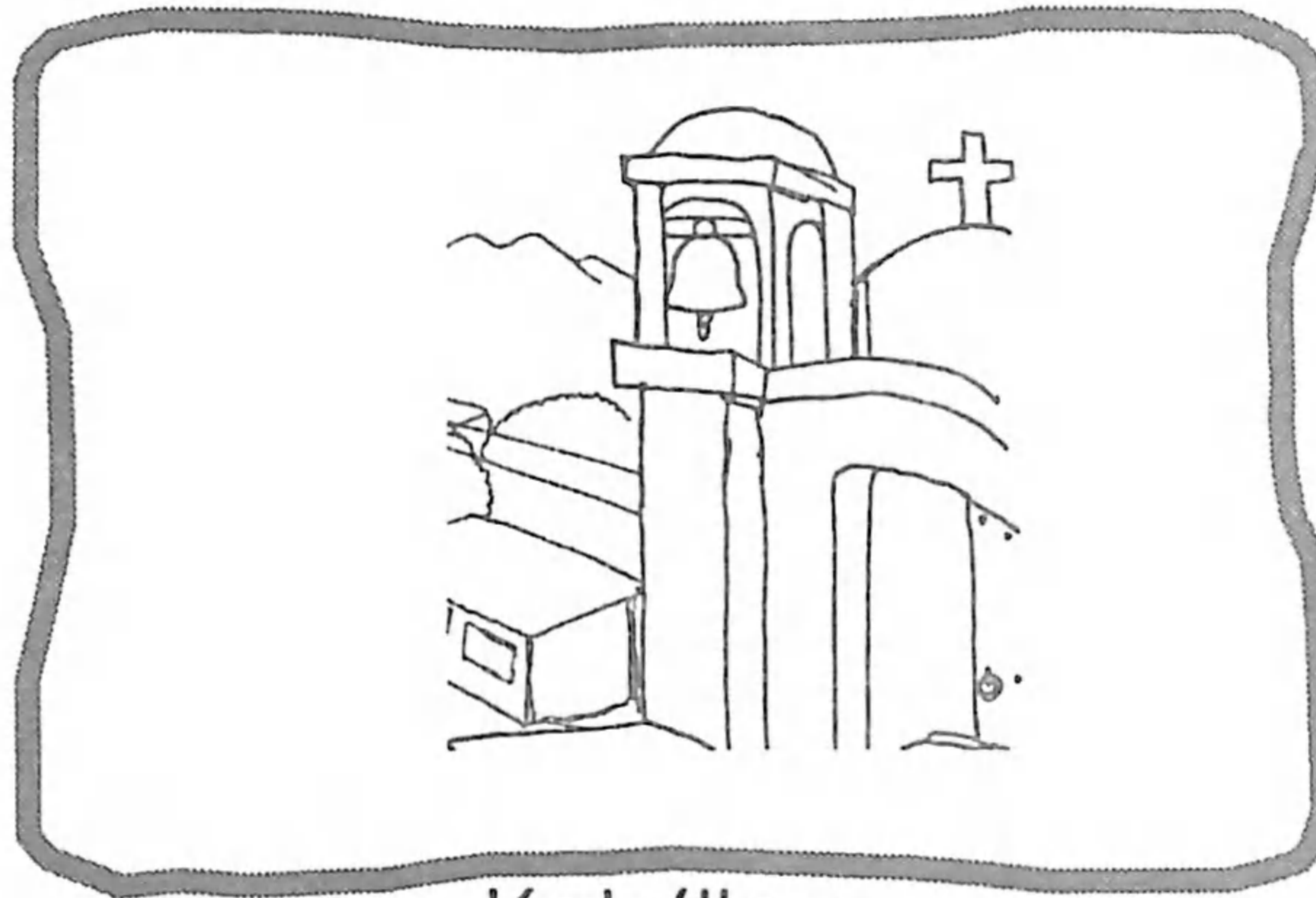

Kotz'ijay

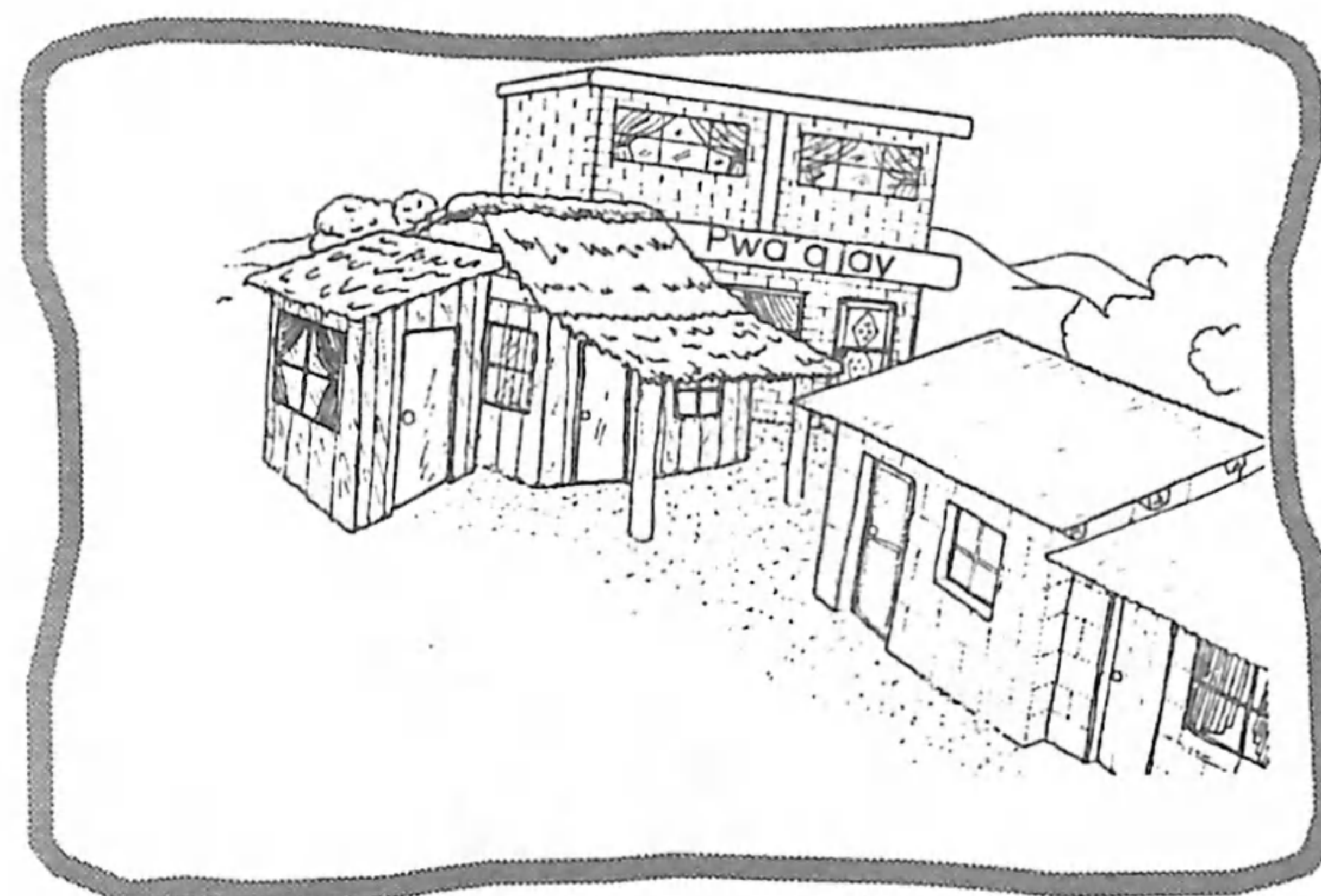

Pwaq jay

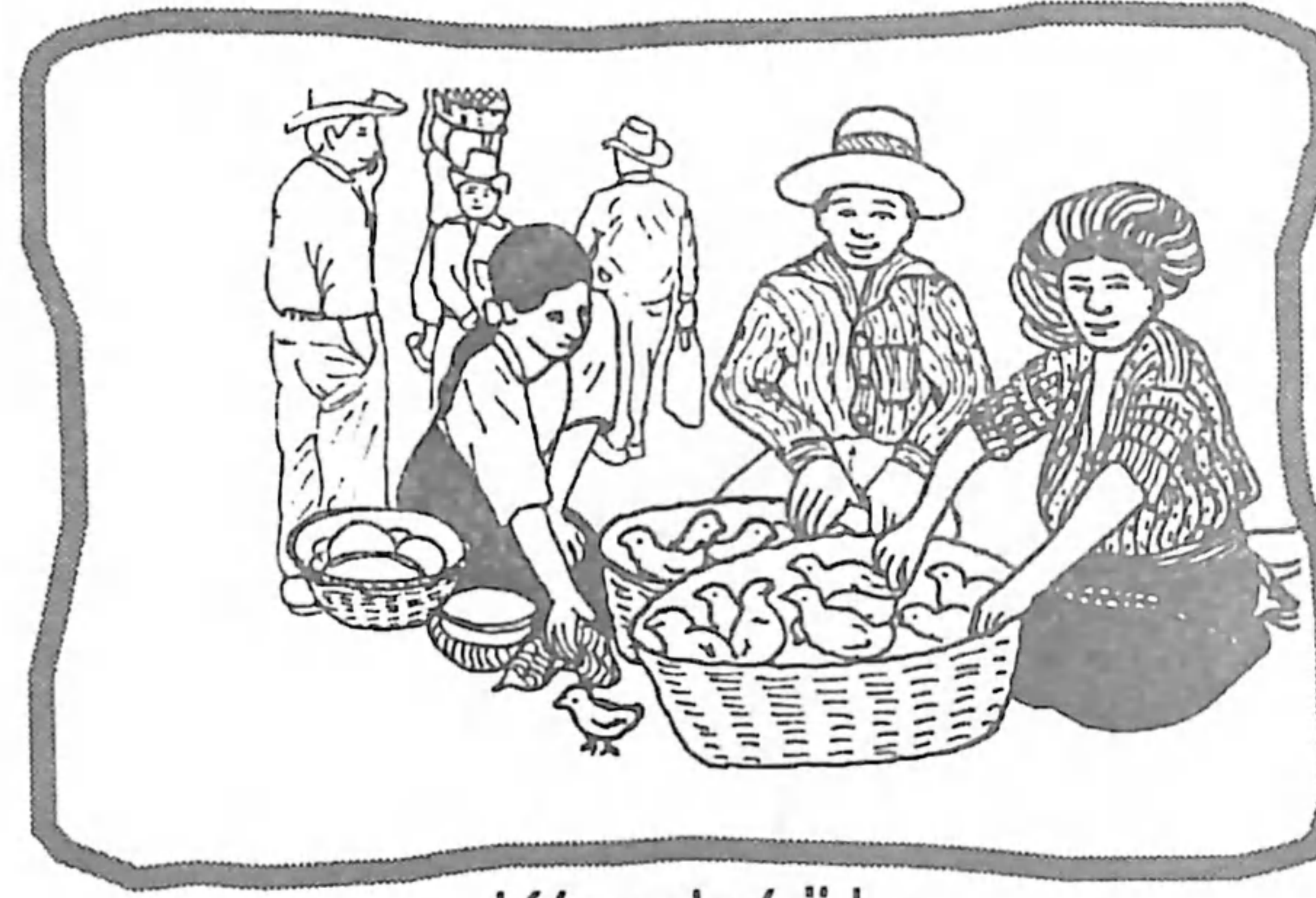

K'ayb'äl

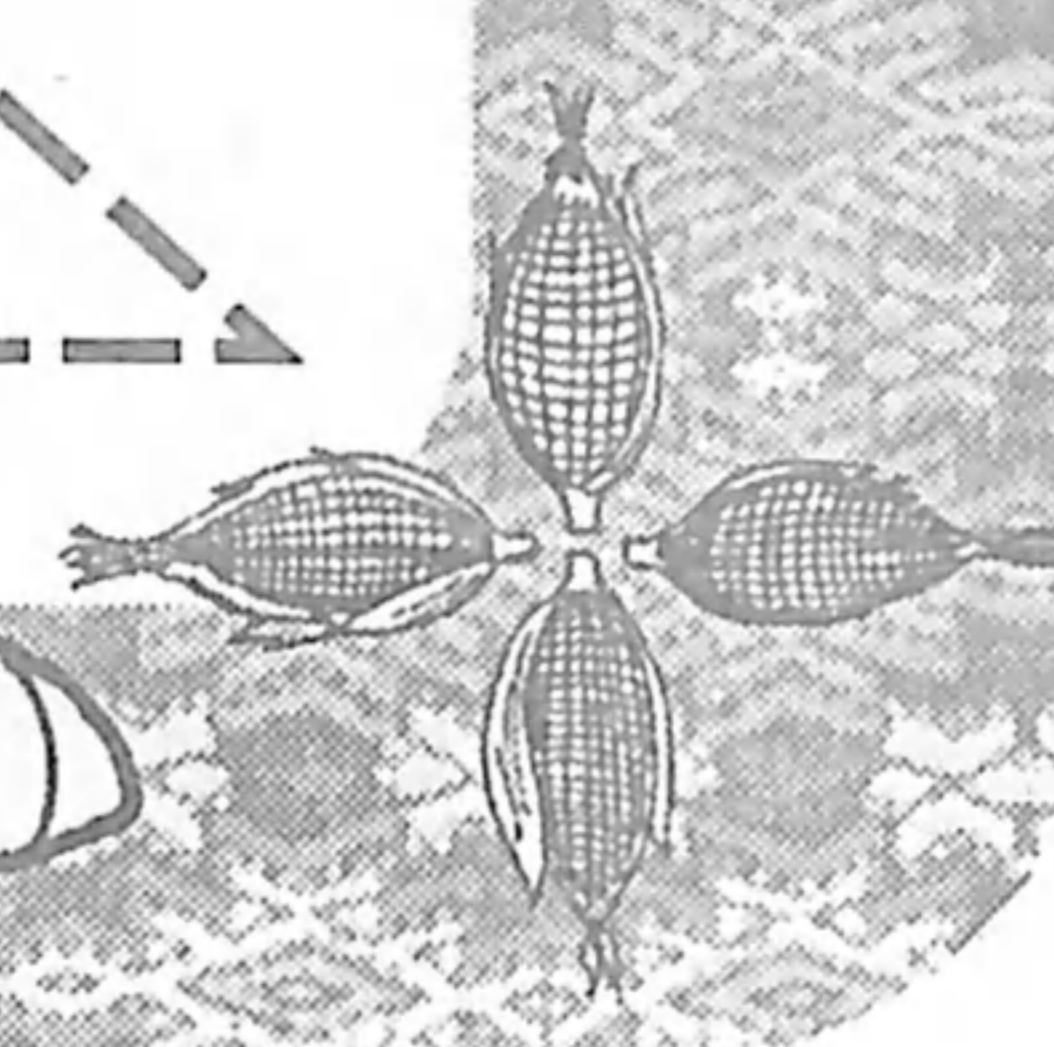
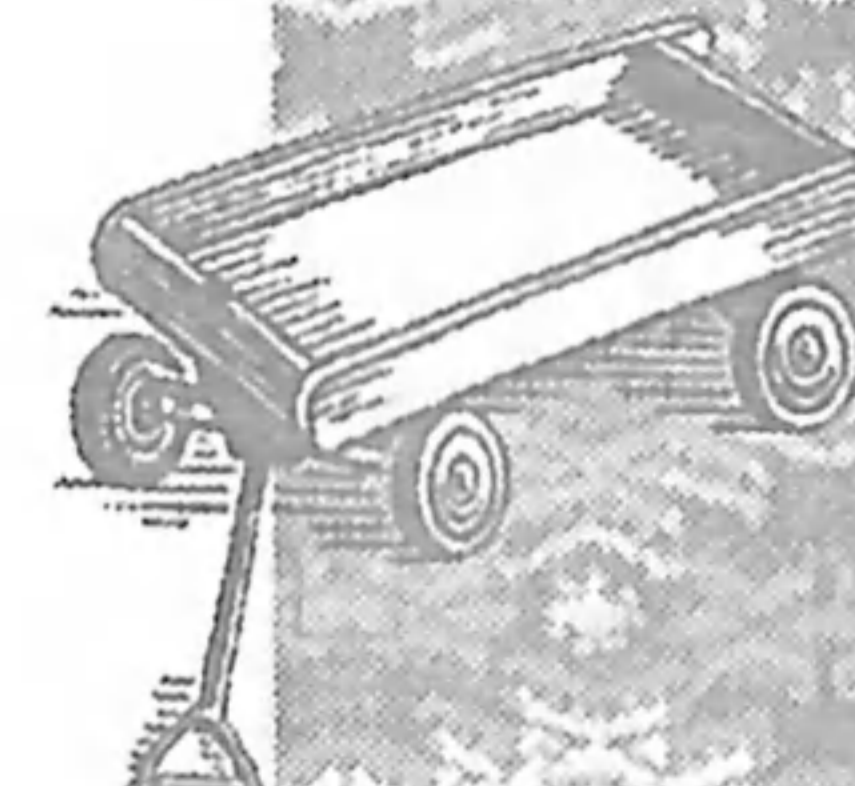
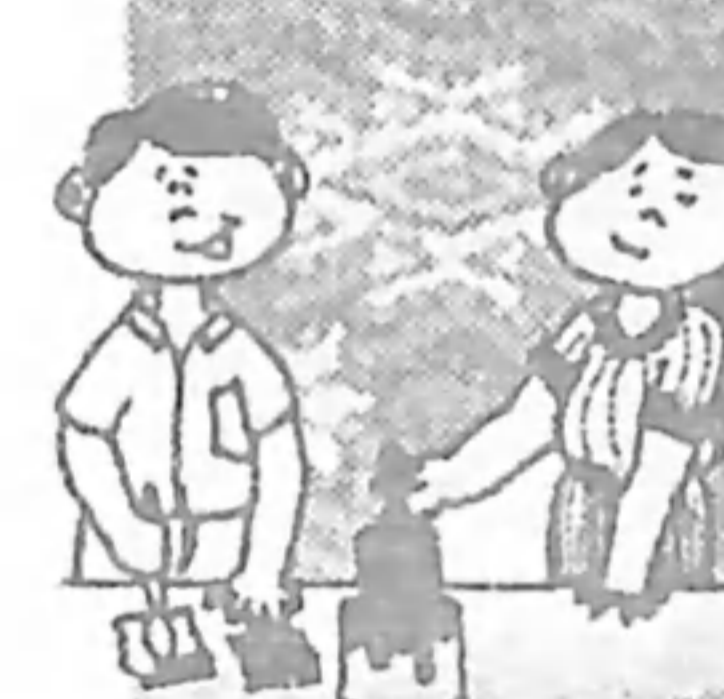

Ri tijoxela' tikirel yekib'än taq achib'äl pa nima'q taq wuj richin ntz'etetäj ri ruch'arik ri qatinamit, chuqa' tikirel nkib'än rub'anikil ri tinamit rik'in che', tz'aläm chuqa' kow wuj.

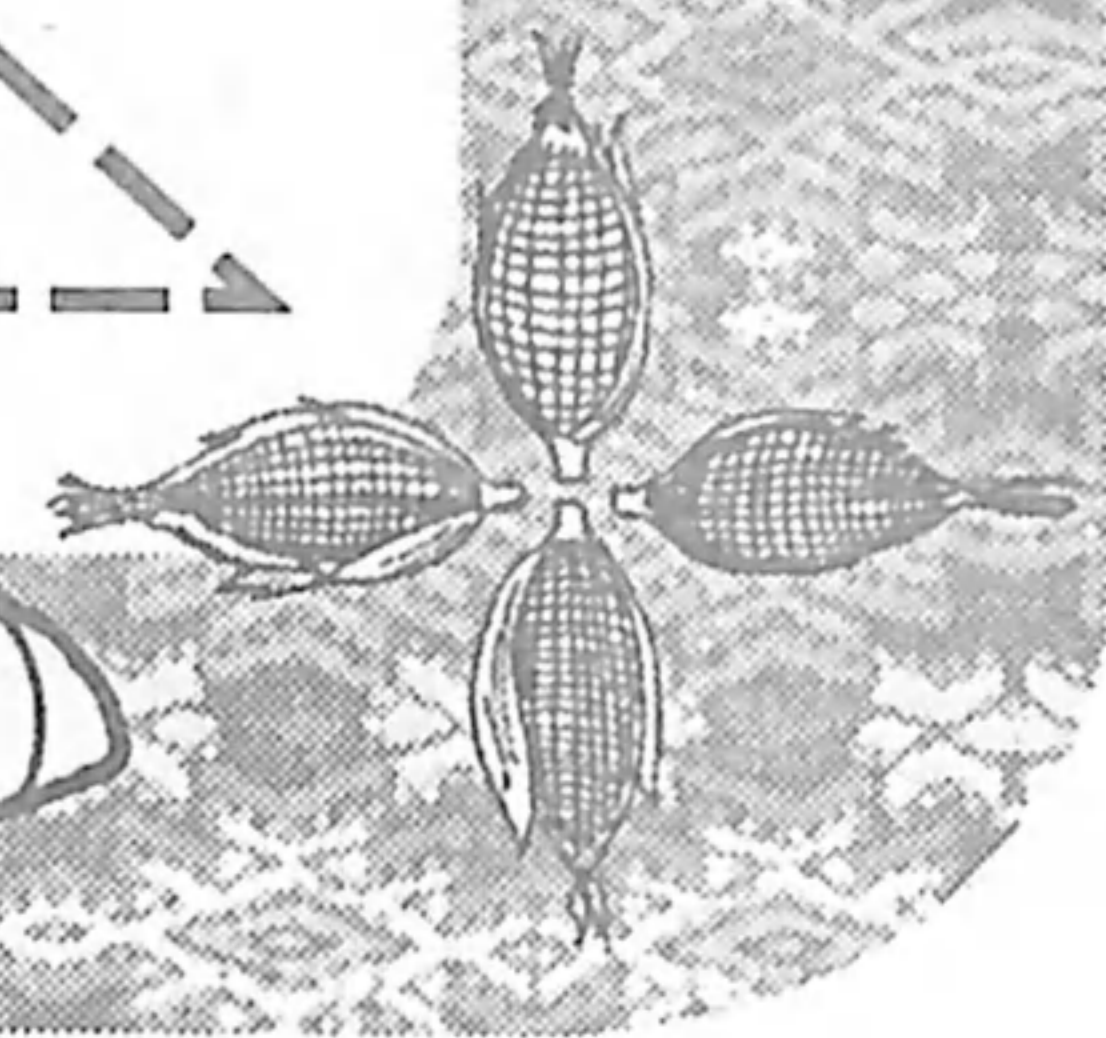

# JALAJÖJ RUWÄCH SAMAJ PA JUN TINAMÏT



Aq'omanel



K'ayinel

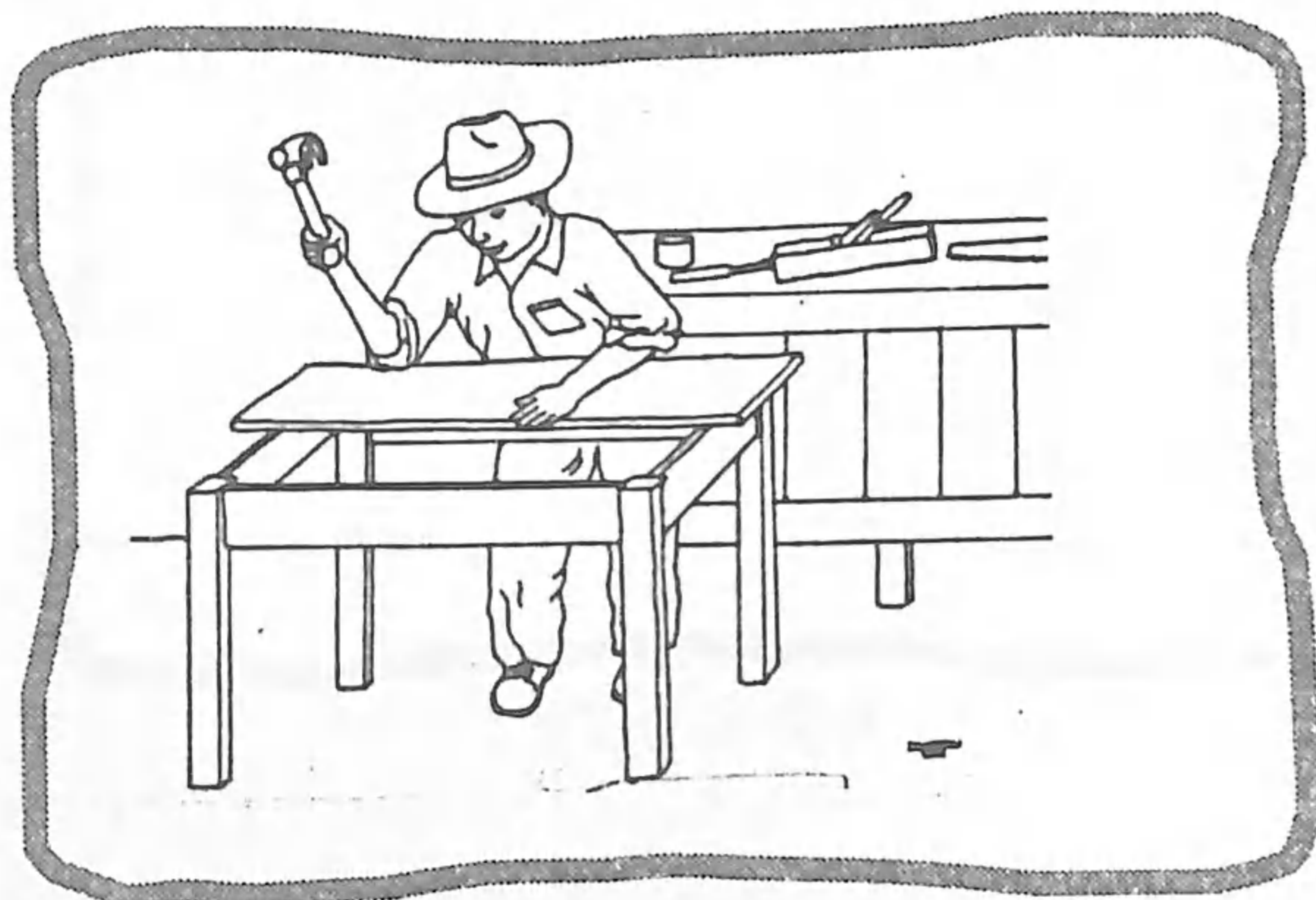

Ajanel

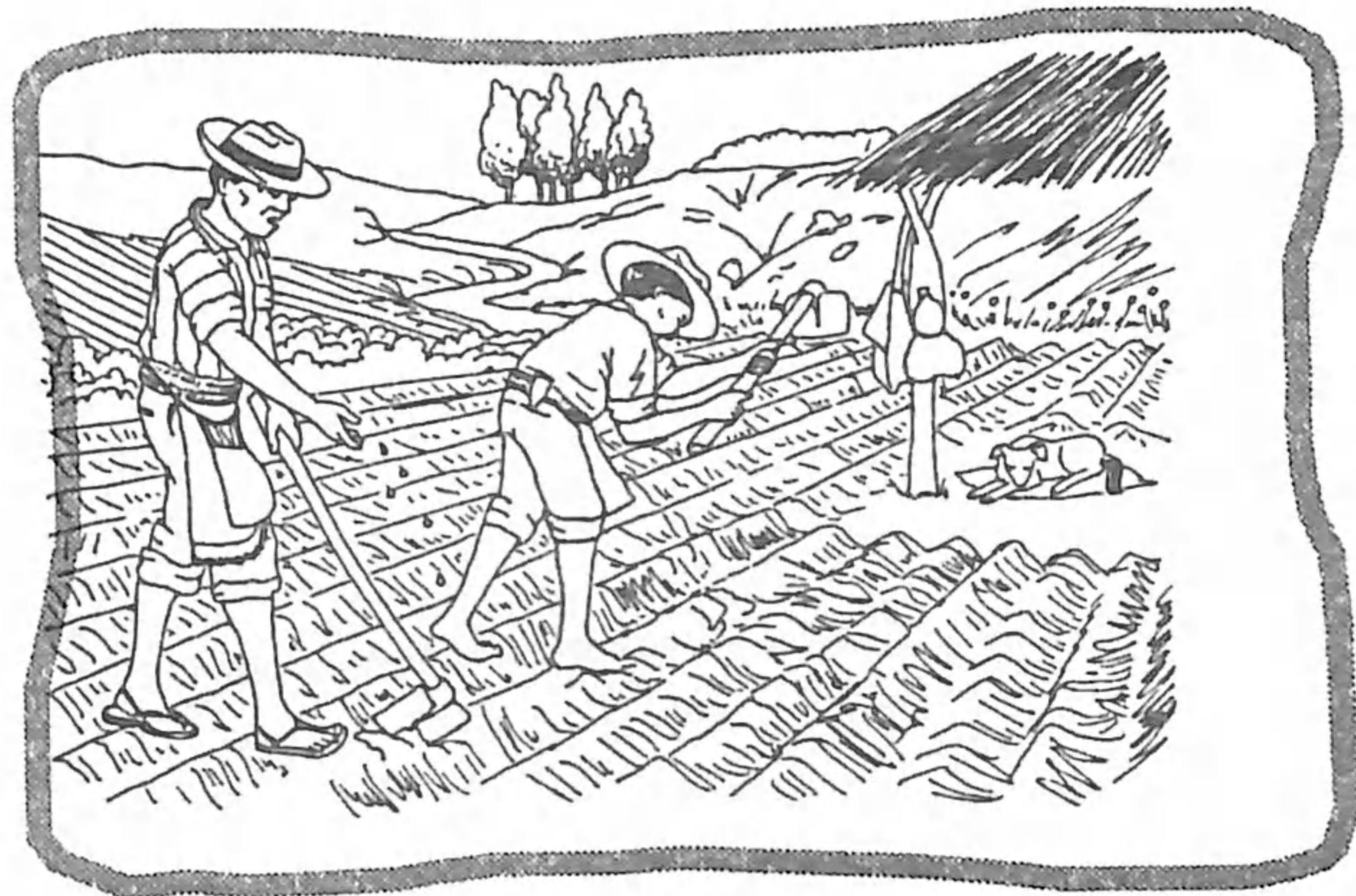

tikonel

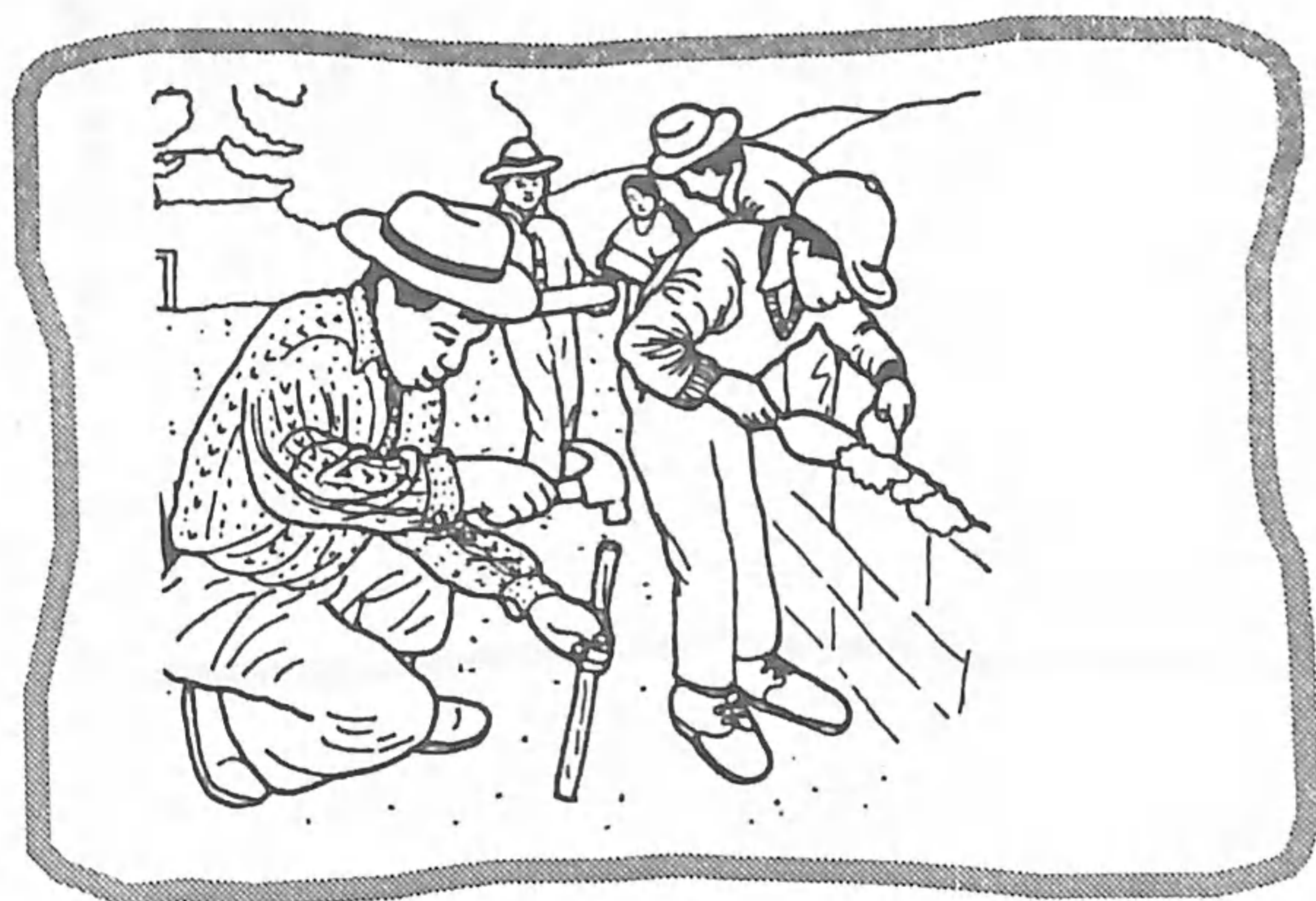

Ajtz' aq



q'atöy tzij

Ri tijoxela' tikirel yekib'an taq achib'al pa nima'q taq wuj richin ntz'etetäj ri ruch'arik ri qatinamit, chuqa' tikirel nb'an jalajöj taq etz'anem.



Jalajöj samaj nkib'än ri winaqi' pa jun tinamit.

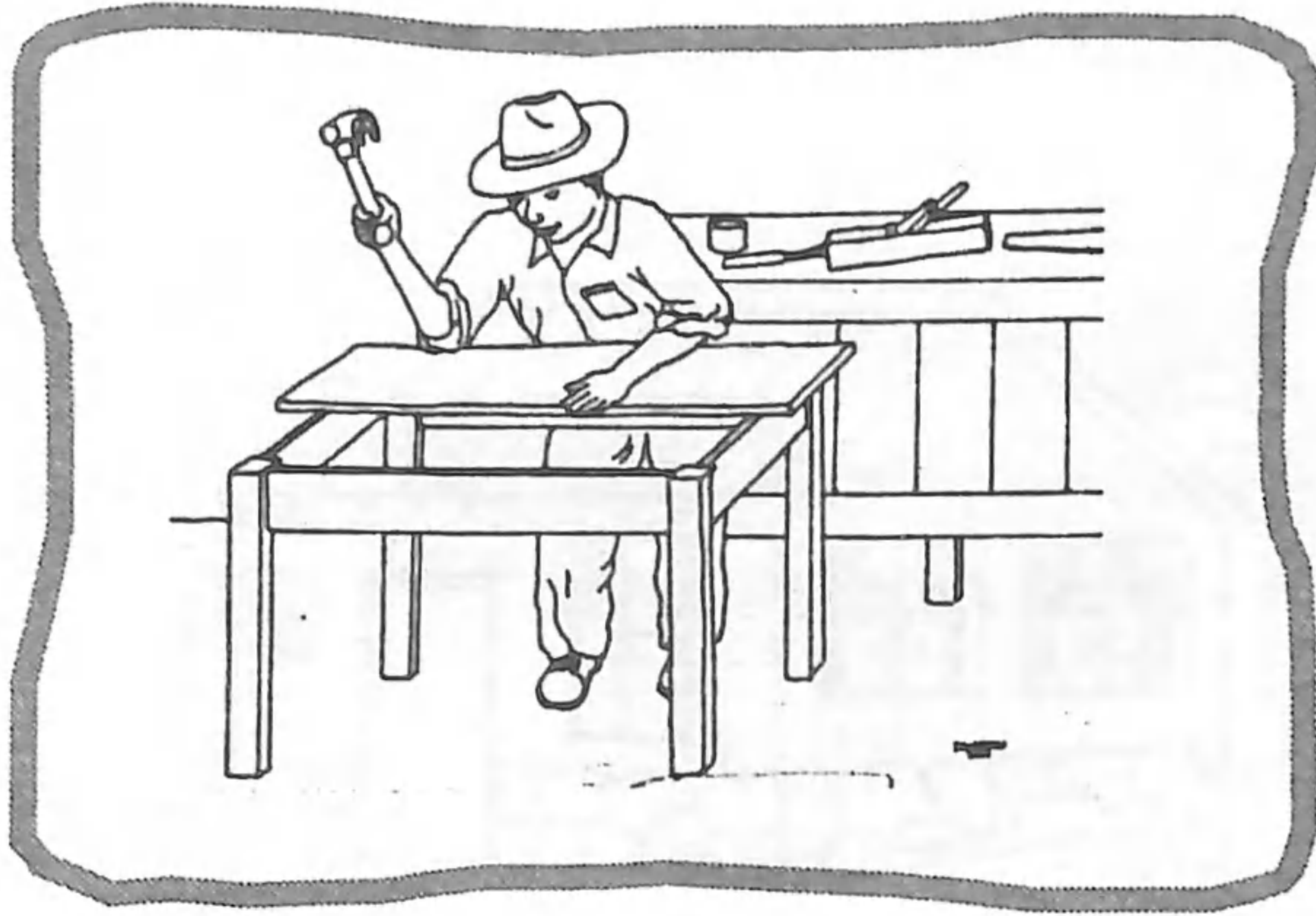

Ri samaj nub'än jun ajanel (njoson)



Ri samaj nub'än jun aq'omanel (naq'oman)



Ri samaj nub'än jun k'amöl b'ey (nuk'waj b'ey)

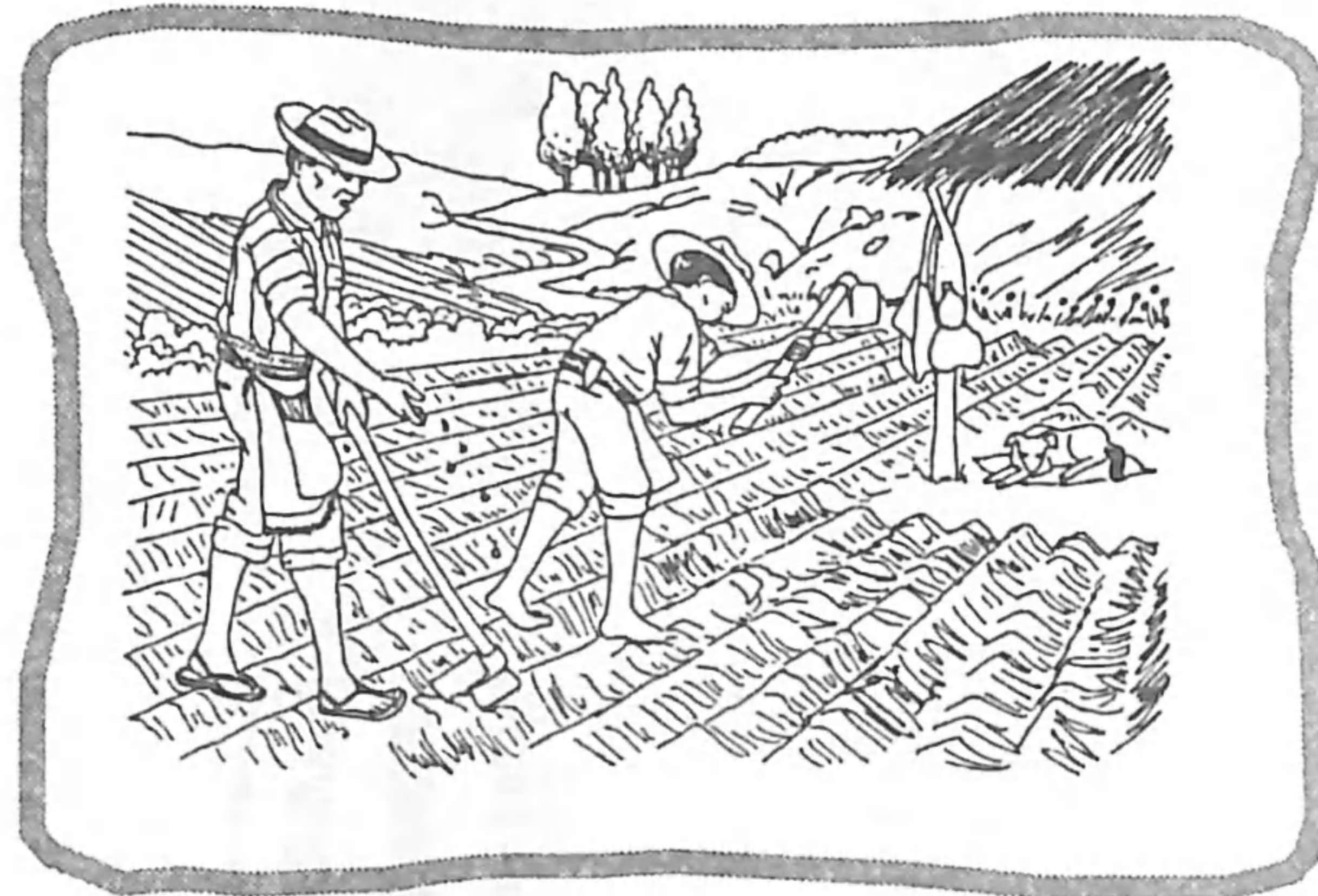

Ri samaj nub'än jun tikonel (ntikon)



Ri samaj nub'än jun k'ayinel (nk'ayin)

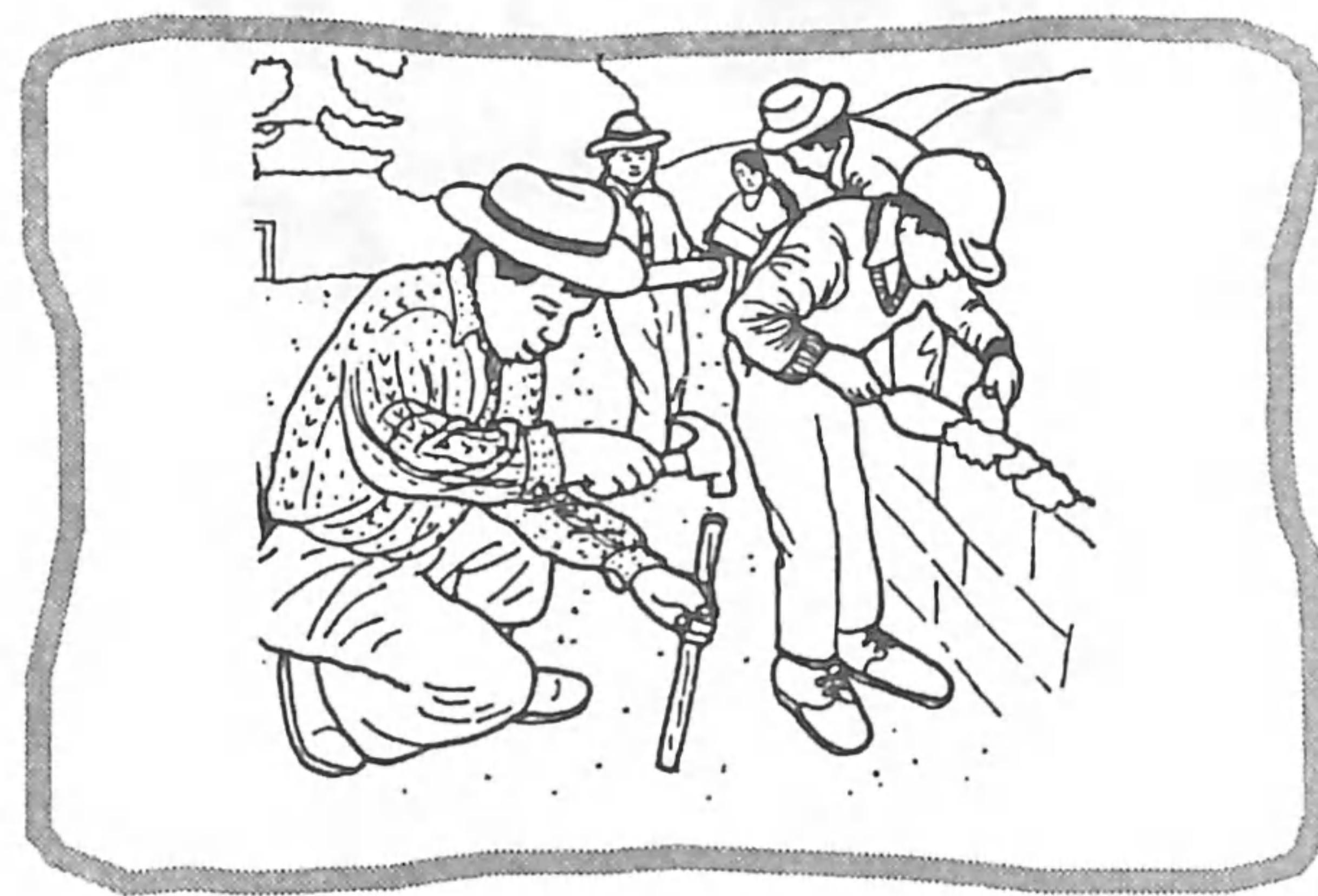

Ri samaj nub'än jun ajtz'aaq (nub'än jay)

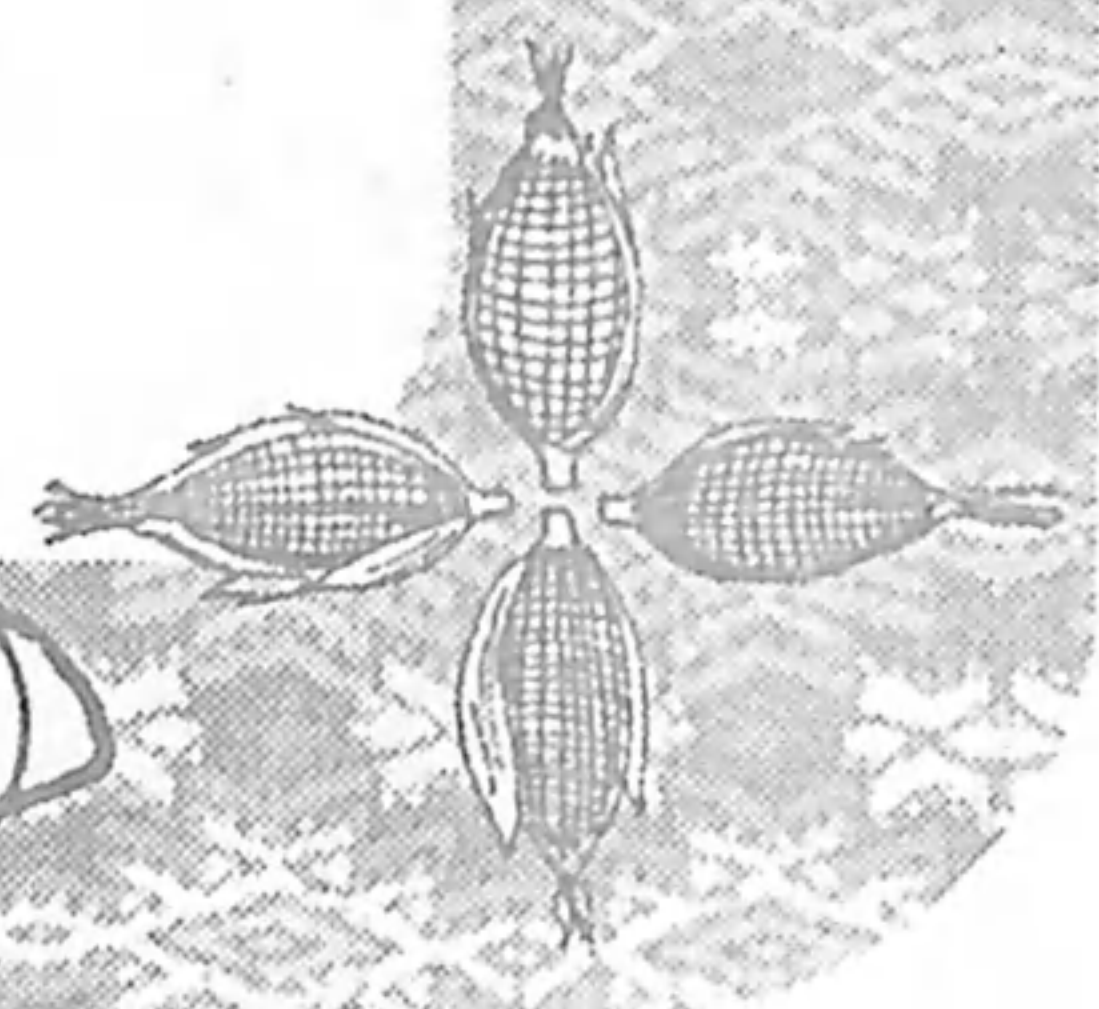
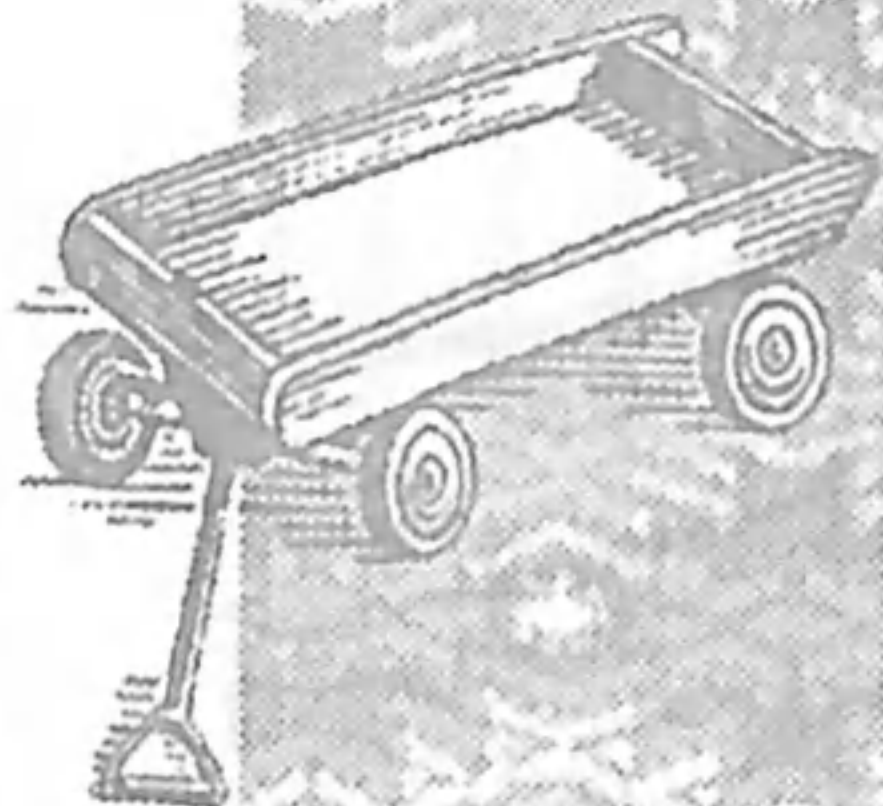



Ri Nwetamaj

# Kojtzijon

Ixchel: Akuchi yatb'e' wi nan.  
 Ixmukane': yinb'e pa aq'omab'al jay  
 Ixchel: Achike nab'eb'ana' pa  
 aq'omab'al jay  
 Ixmukane' yinb'e chi rutz'etik jun nuyawa'  
 Ixchel Tachajij awi' k'a nan  
 Ixmukane Matyox chawe  
 Chwa'q chik.  
 Ixchel: Chwa'q chik matyox.

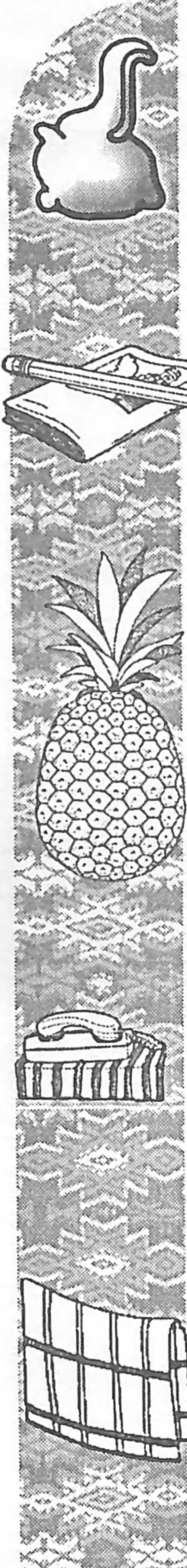

Ixkoq'ij Akuchi yatb'e' wi tat.  
 Ajpu' Yinb'e pa samaj pa tinamit  
 Ixkoq'ij: Achike k'a samaj  
 Nab'eb'ana'  
 Ajpu': Ninb'enub'ana' jun jay  
 Ixkoq'ij: Tachajij awi' k'a tat  
 Ajpu' Matyox chawe nan  
 Ixkoq'ij Chwa'q chik  
 Chwa'q chik matyox.

Ri tijoxela' tikirel nkib'an pa etz'anem re jun tzijonem re', chuqa' utz tikitijoj ki' jantape' richin nketamaj pa rub'eyal.



# Kojtzijon

Lu' : Achike rub'i' ri atinamit rat Ixkem

Ixkem: Pa Su'm rub'i' ri nutinamit rin.

Ixkem: Achike rub'i' ri atinamit rat.

Lu': Iximche' rub'i' ri nutinamit rin.

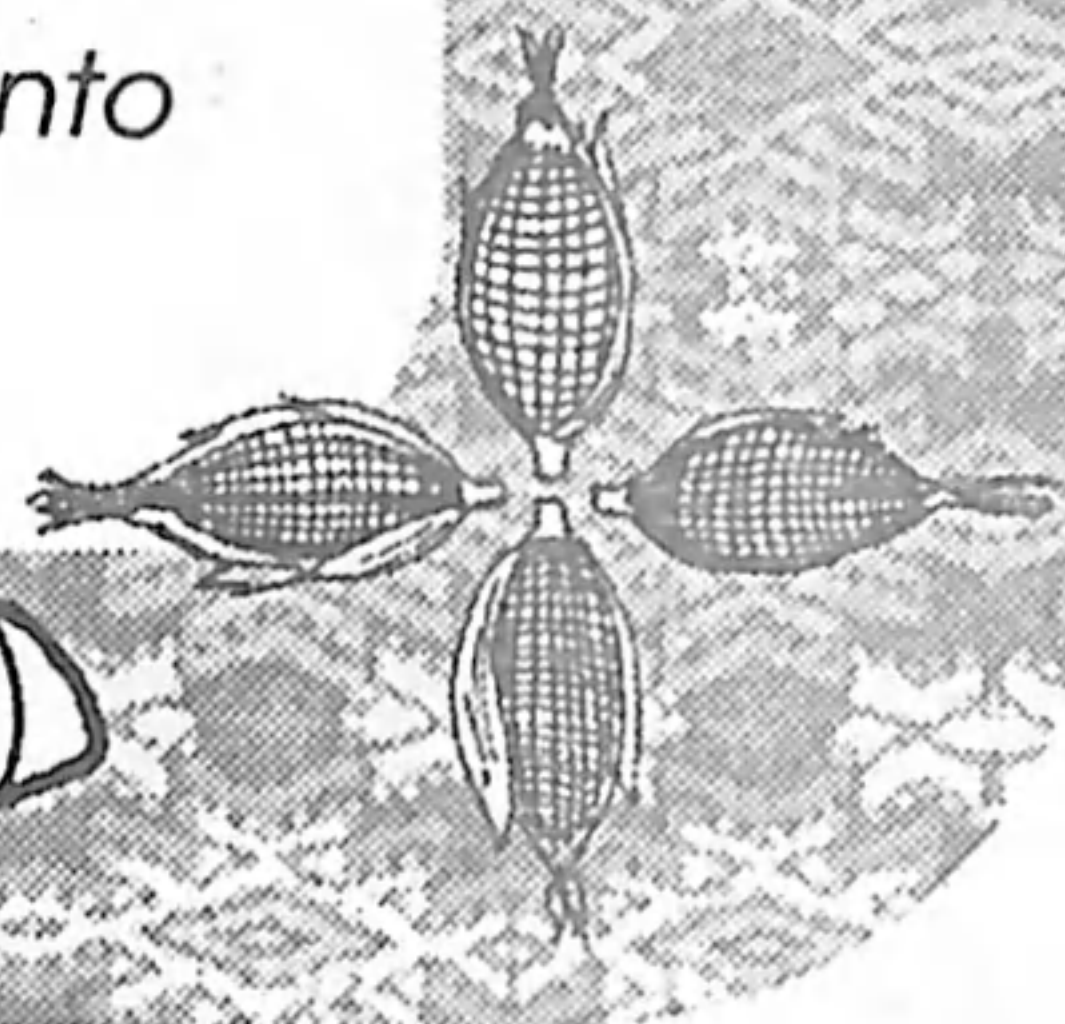
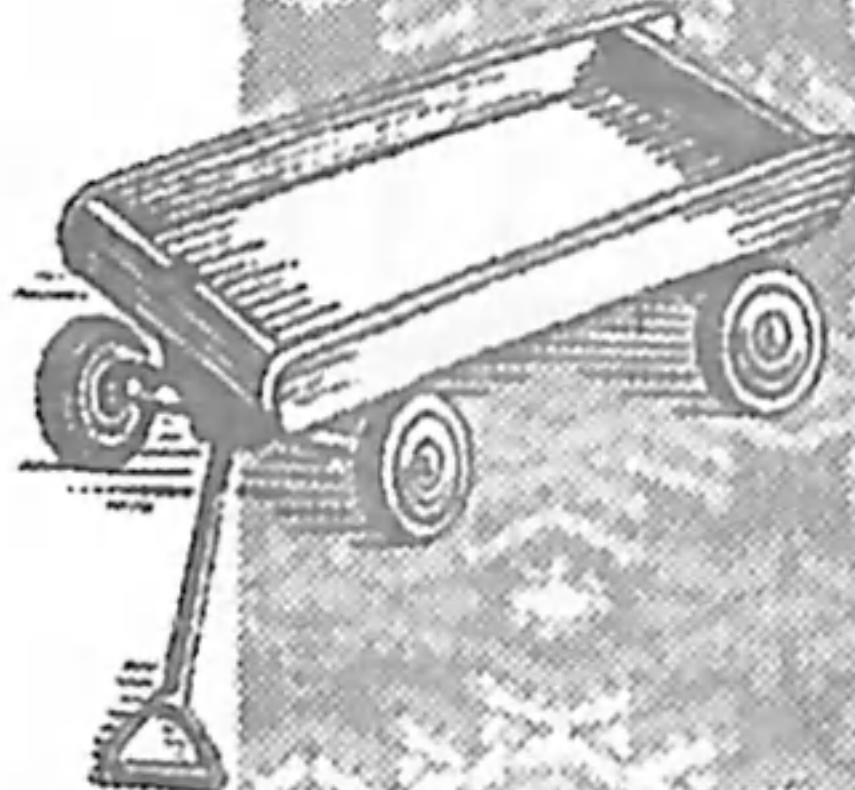

## Pa Su'm (B'ix)

Pa Su'm Pa Su'm

rub'i' ri qatinamit (Kamul)

Kojkikot kojikot

rik'in ri qatinamit (Kamul)

Röj aj Pa Su'm (Kamul)

käq rub'onil ri qapo't (Kamul)

achi'el releb'al ri q'ij (Kamul)

Re b'onil re' yalan rejqalem

yalan rejqalem pa qana'oj

Röj aj Pa Su'm (Kamul)

pa Su'm, Pa Su'm rub'i' ri

qatinamit. (Kamul)

*Tz'ib'anel chuqa' ya'öl ruq'ojom:*

*Felipa Gonzáles Sinto*

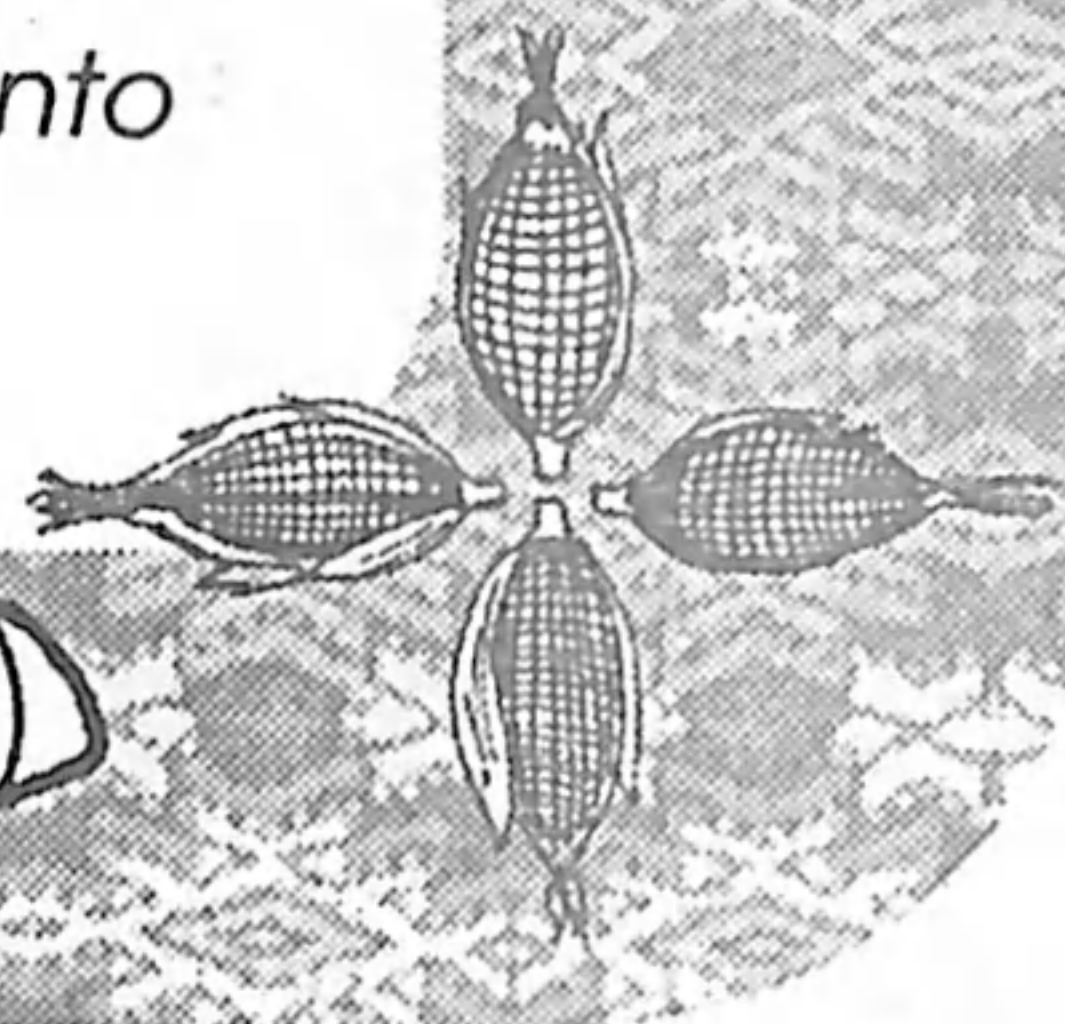
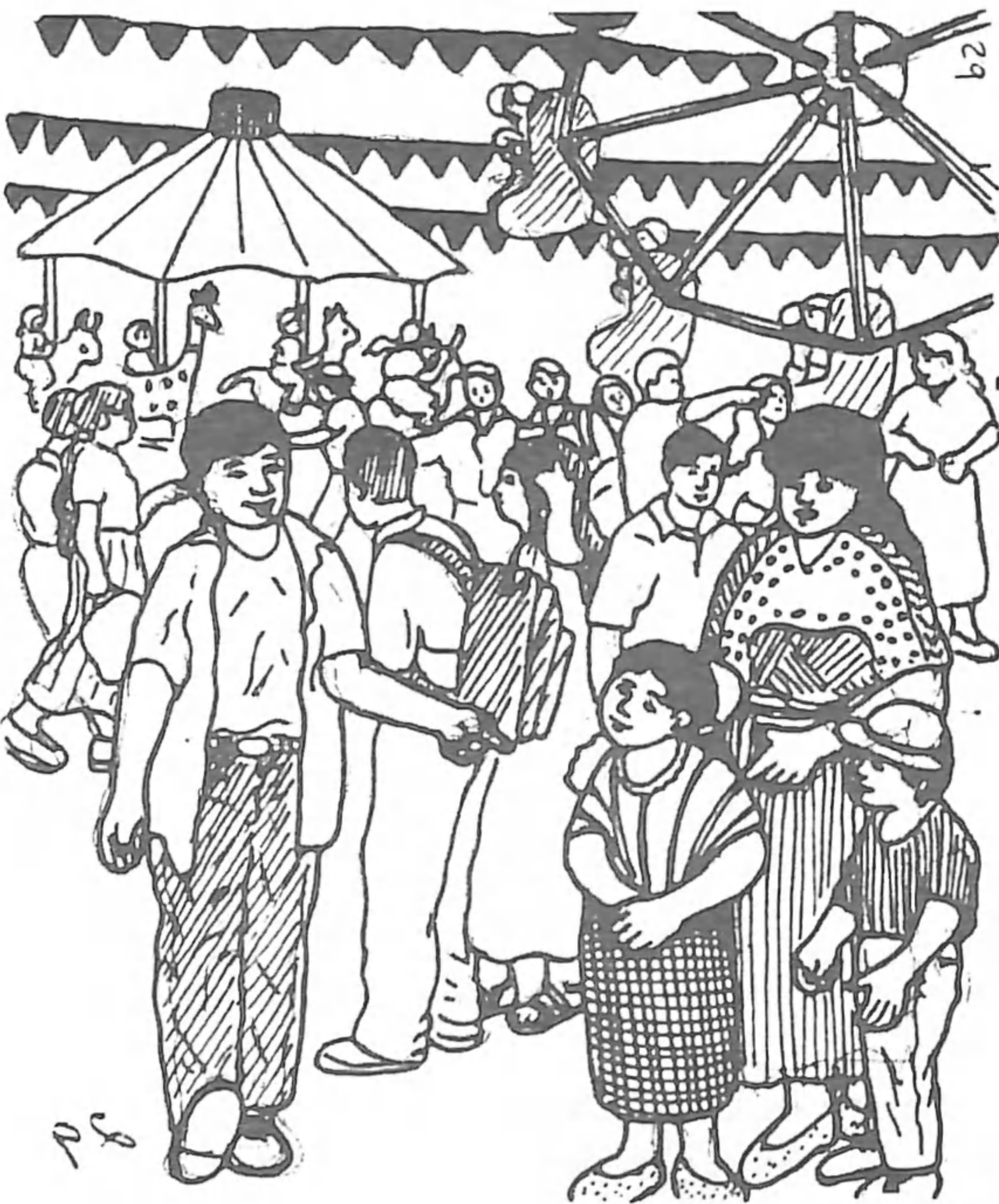

# Nimaq'ij

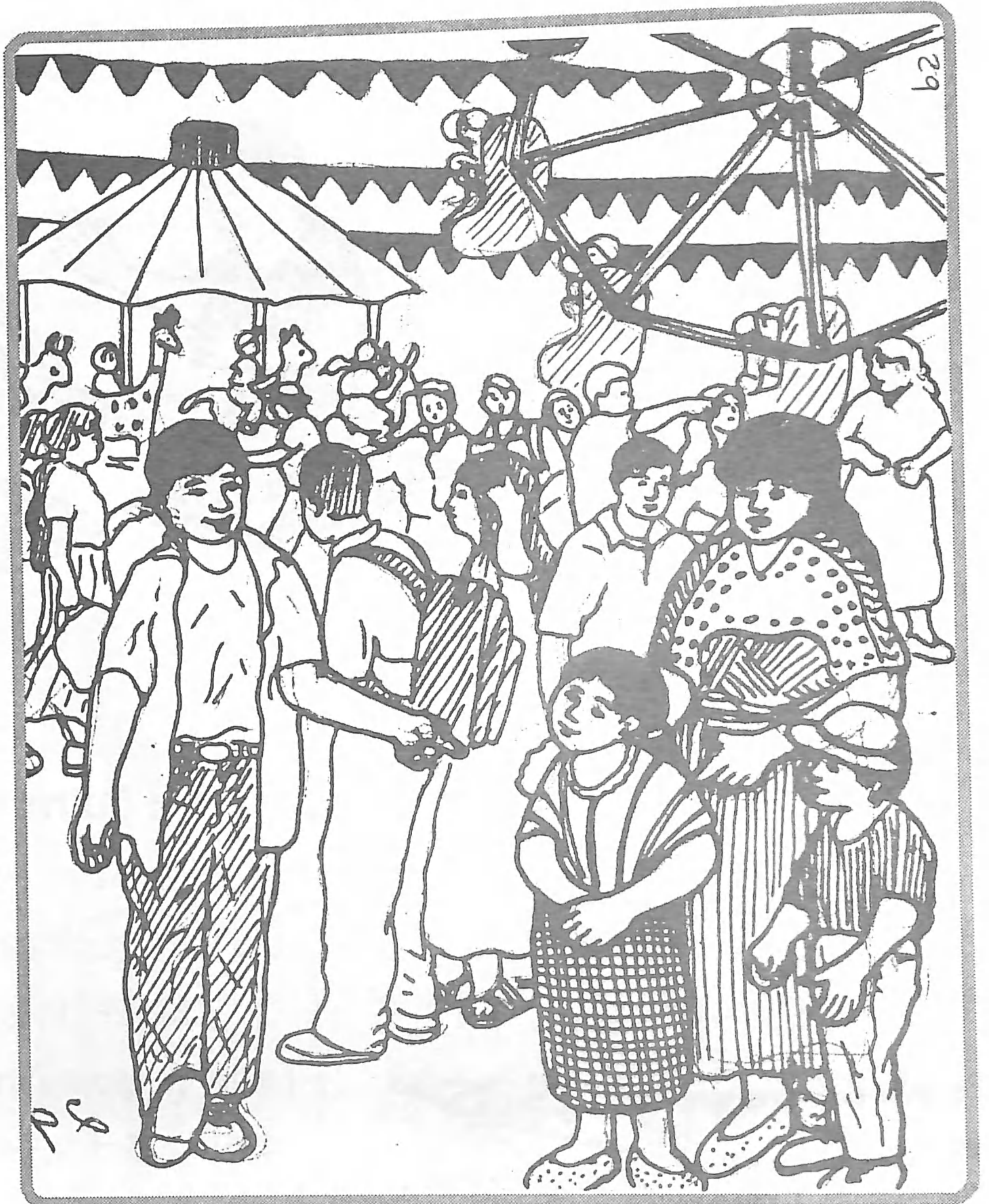

Ja re' jun nimaq'ij  
pa nimaq'ij e k'o winaqi'.  
Pa nimaq'ij e k'o k'iy etz'anem.  
Pa nimaq'ij k'iy wachinäq yek'ayix.  
E k'iy winaqi' yeb'iyaj.  
Jeb'ël yek'astan la winaqi'.

## Soloj samaj:

Ri tijonel nub'ij chi ke ri tijoxela' chi tkich'ob'o chi kiwäch achike nkib'än ri nimaq taq winäq töq yek'astan, k'a ri nkib'än jun rachib'äl, chuqa' jun achib'äl chi rij ri kik'astanik ri ak'wala'.



# Kojtzijon pa ruwi' ri runimaq'ij ri qatinamit

Kojtzijon



Kojtzijon

Lu' : Janipe' nik'o runimaq'ij ri atinamit rat Ixkem  
Ixkem: pa B'eleje' No'j, nq'ax runimaq'ij ri nutinamit  
Ixkem: Lu' janipe' nq'ax runimaq'ij ri atinamit  
Lu' : Pa jun kej nq'ax runimaq'ij ri nutinamit.  
Ixkem: Achike nk'ayix pa runimaq'ij ri atinamit.  
Lu' : Jalajöj wachinäq yek'ayix, achi'el mani',  
kab', tzyäq, etz'ab'a'l.

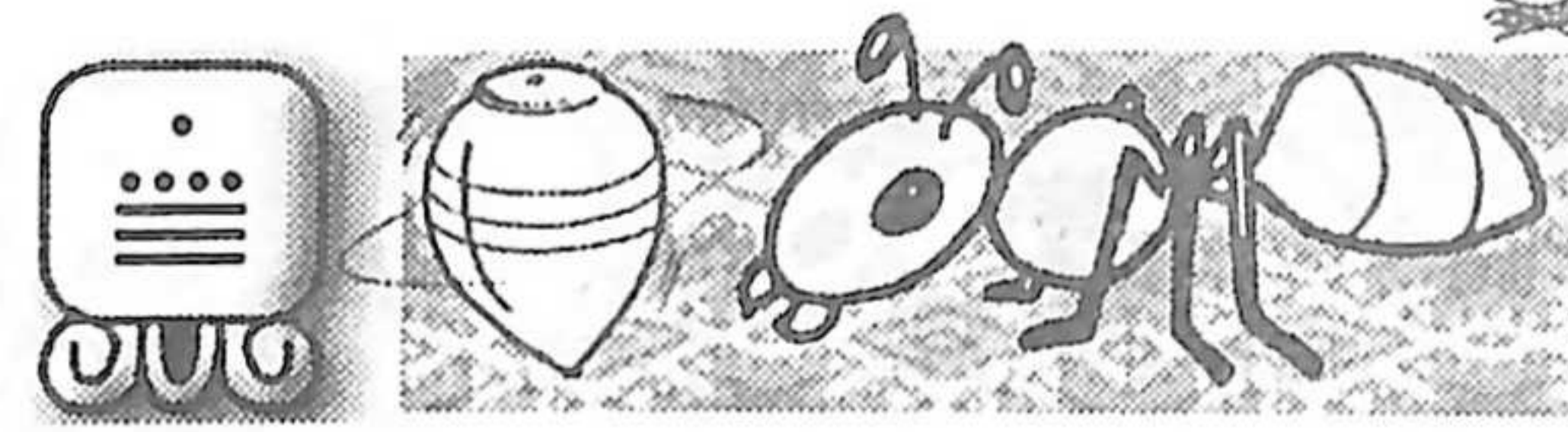
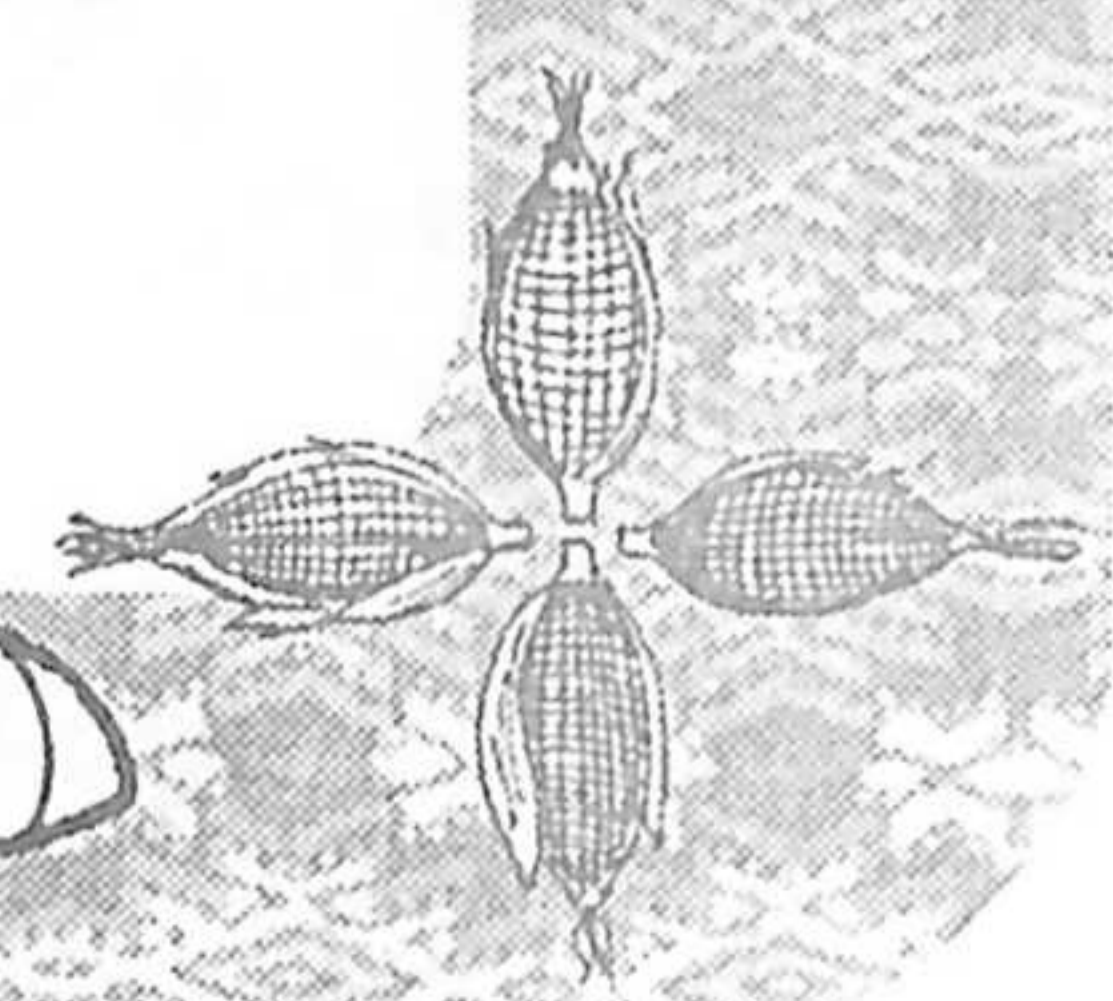
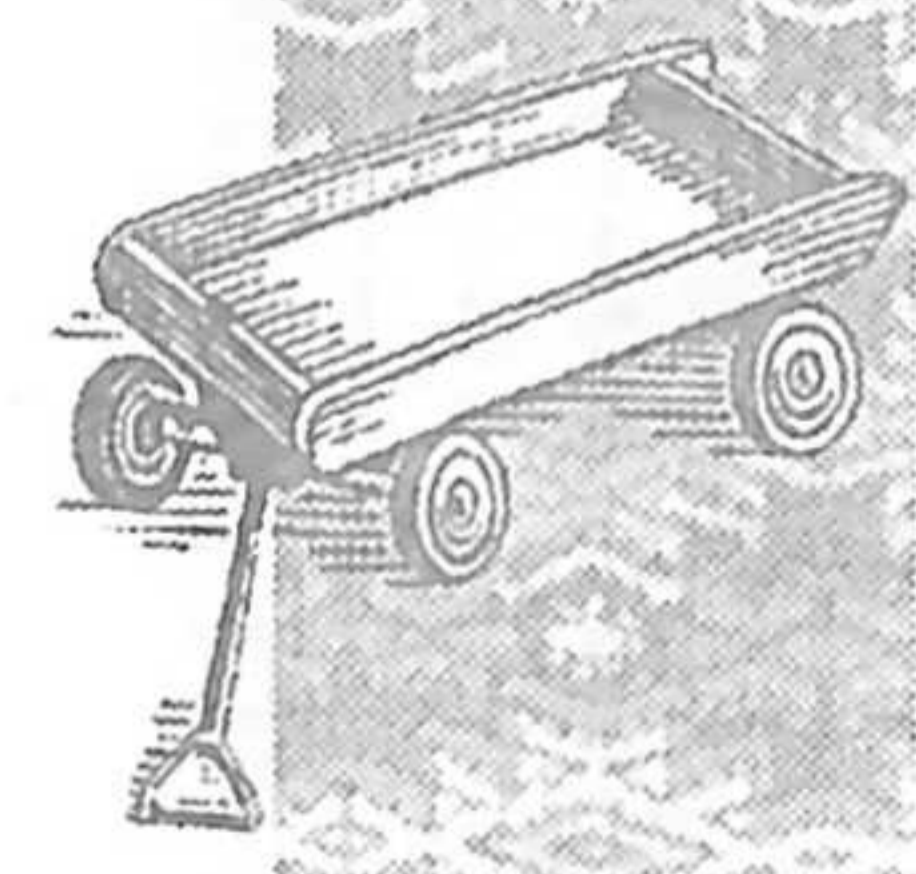





### Kojtzijon

Ixch'umil: La awetaman ri tinamit Semetab'äj rub'i.

Saqche': Ja' rin wetaman

Ixch'umil: La ch'utin ri tinamit

Saqche': Manaq man ch'utin ta. Nim re timamit re'.

Ixch'umil: Nim ri tinamit. ¿La jeb'ël?

Saqche': Ja' janila jeb'ël ok re tinamit re'

Ixch'umil: La nim ri B'oko'

Saqche': ja' nim

Ixch'umil: La nim ri Tz'olaj Ya'.

Saqche': Man kan ta nim

Ixch'umil: La ech'utin ri Chi Masat.

Saqche': Ja' ch'utin

Ixch'umil: ¿La näj ri B'oko'?

Saqche': Manaq. Man näj ta xa naqaj

Ixch'umil: La näj ri Tz'olaj Ya'.

Saqche': Ja' näj ri Tz'olaj Ya'.

Ixch'umil: ¿La tew ri B'oko'?

Saqche': Ja' tew jub'a'

Ixch'umil: La Tz'olaj Ya' chuqa'.

Saqche': Ja' ri Tz'olaj Ya' yalan tew nub'an.

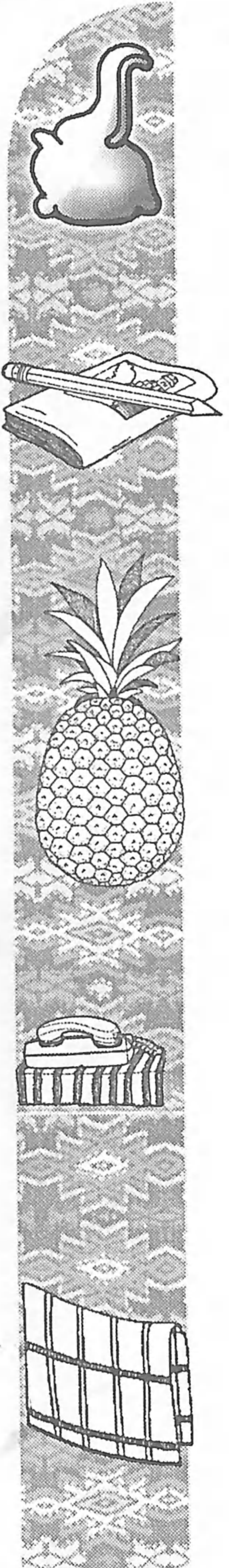

Ütz tkib'ana' re jun tzijonem re' pa kaka'.

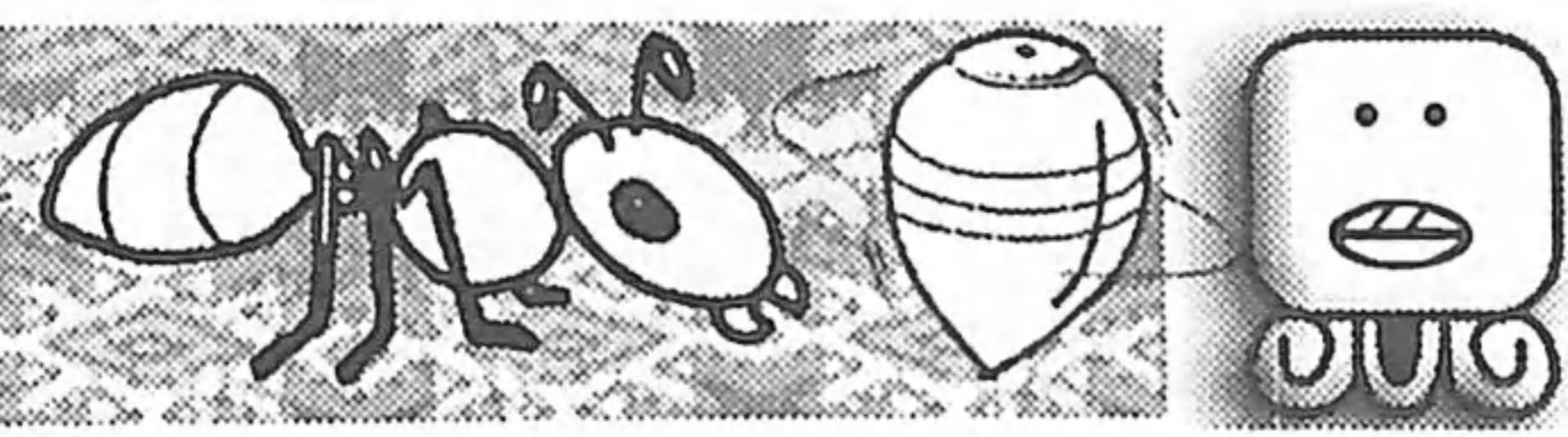

# Ri xqetamaj

Kojtzijon pa ruwi' re jun achib'al re'



A large rectangular area with horizontal lines for writing. A pencil icon is positioned at the bottom right corner of this area.

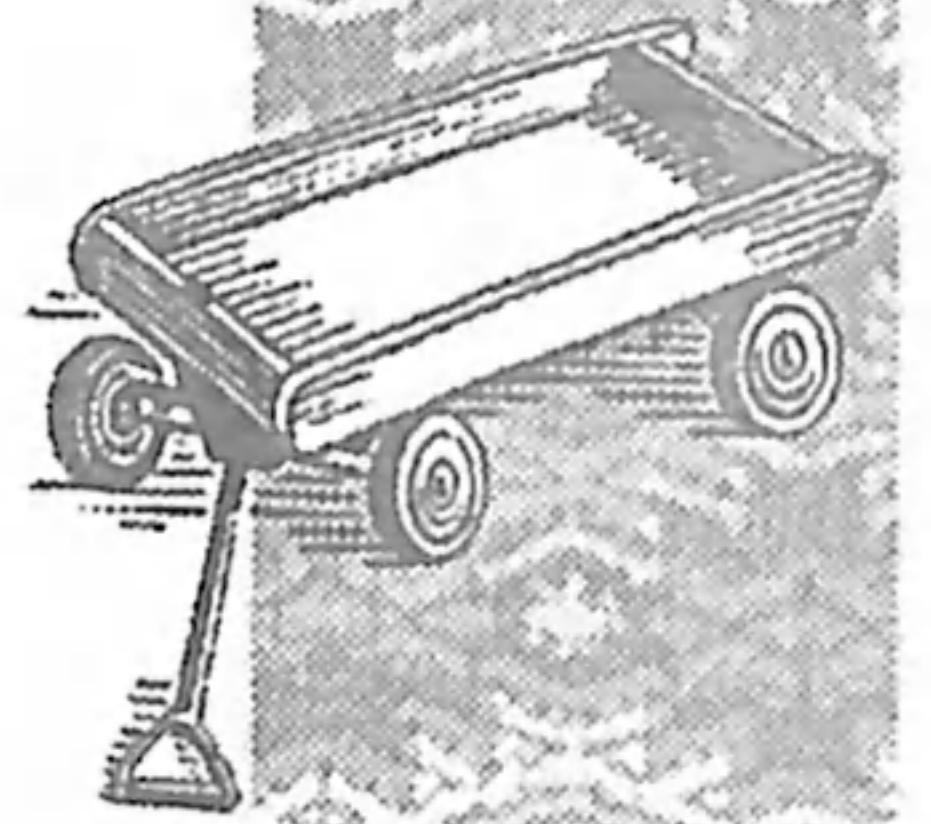
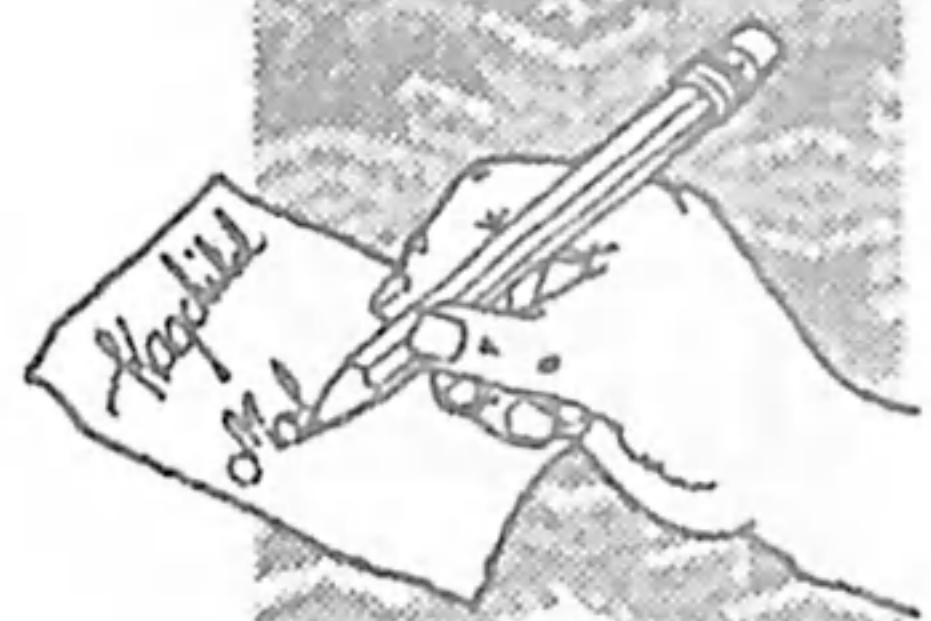

Ri tijoxela' yetzijon pa ruwi' ri achib'al chuqa' nkitz'ib'aj  
pa ruwi' ri taq juch' ri nkitz'ët.

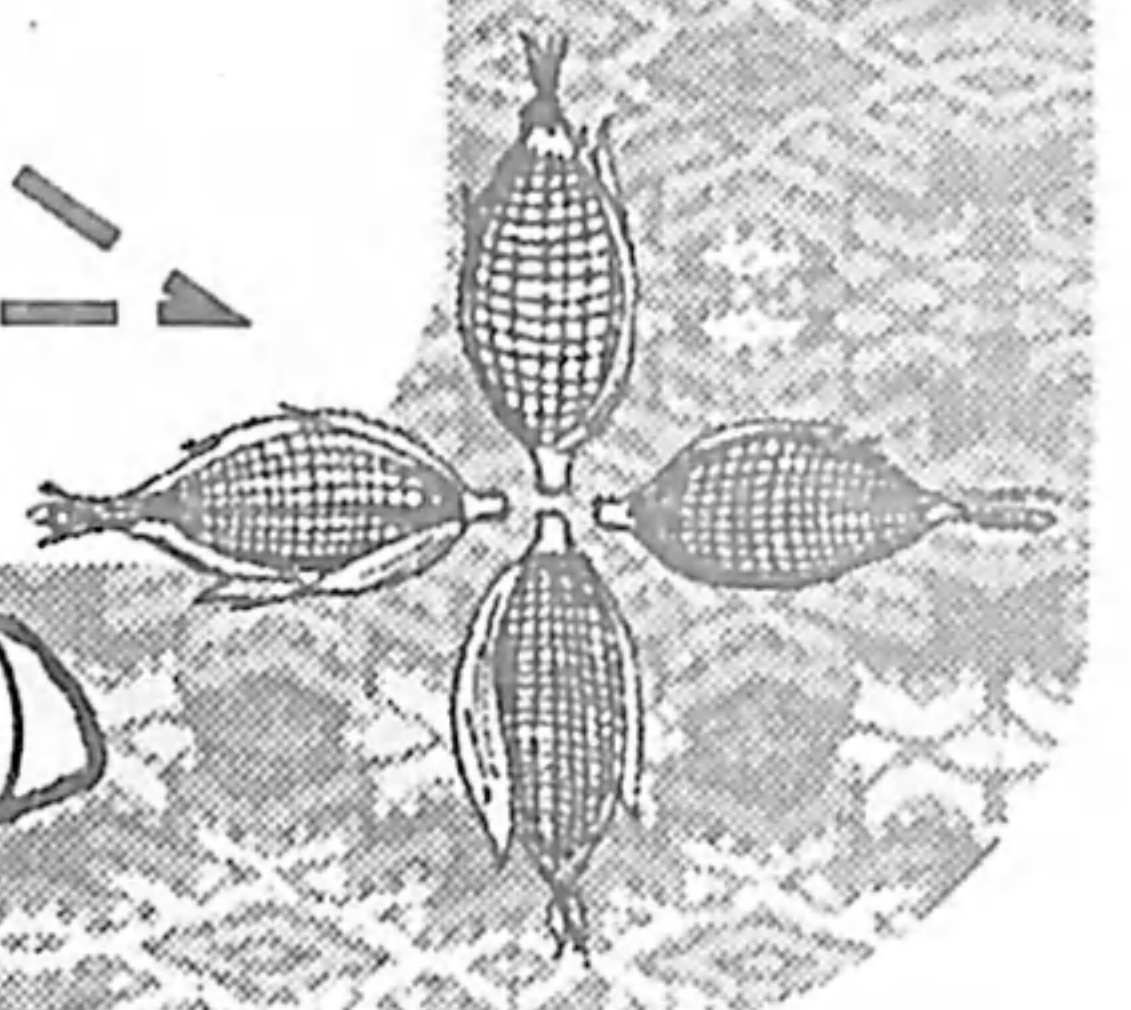

# Tqatz'ib'aj kib'i' ri ruch'arik jun tinamiit.

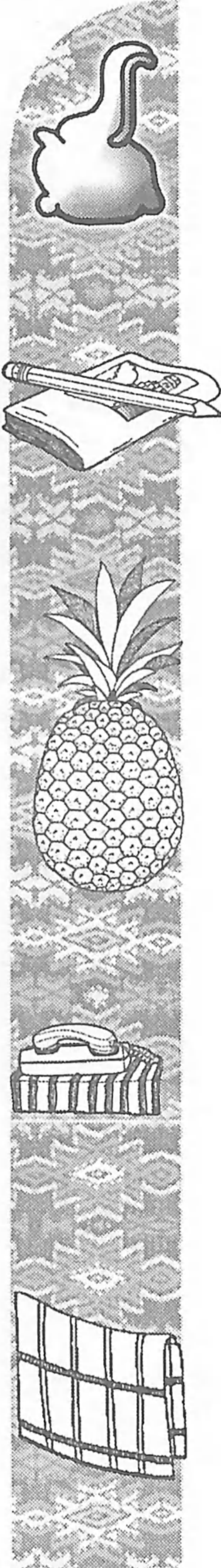
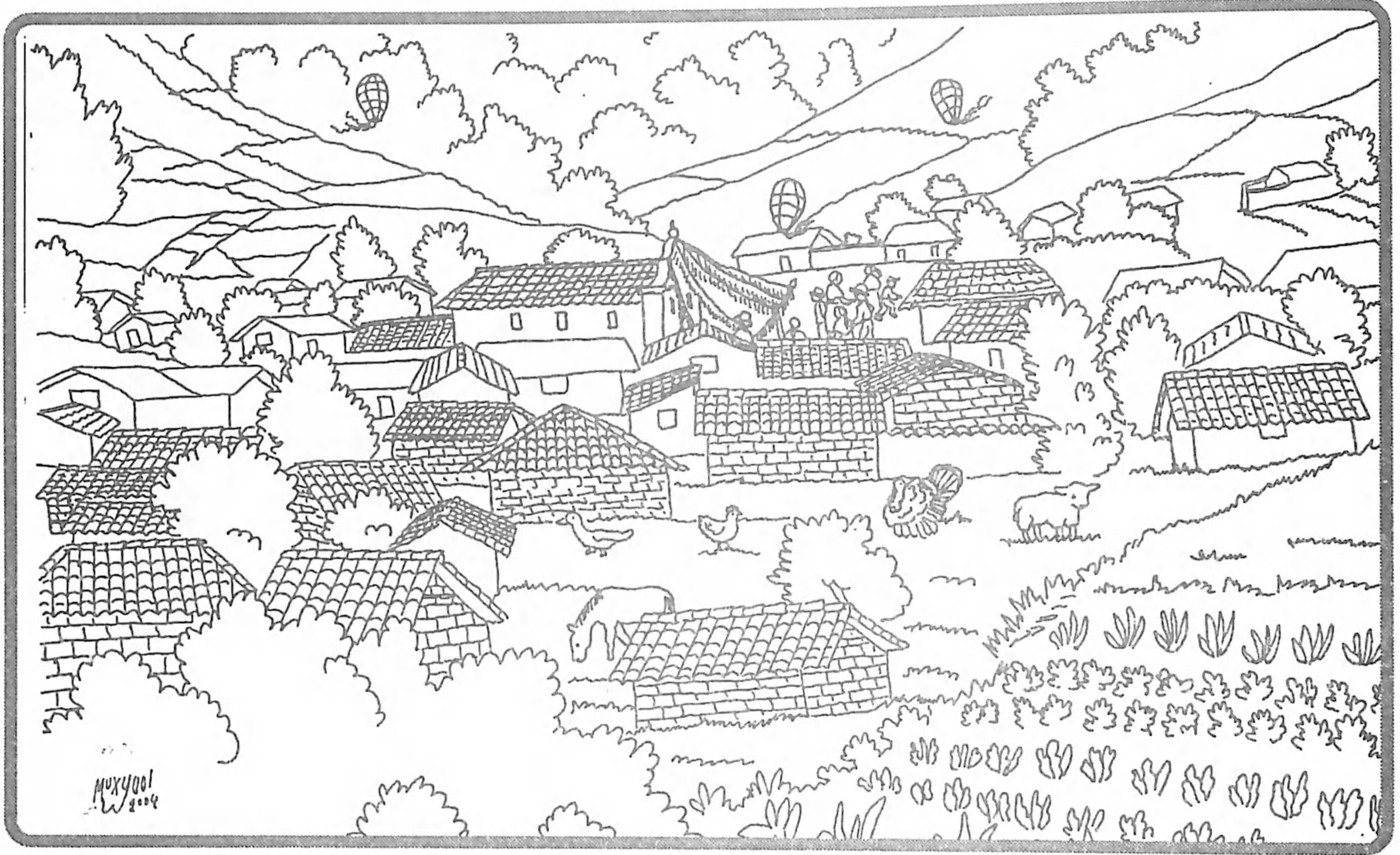

Ri tijoxela' tikirel nkinük' jun kitinamit chuwäch pim wuj, tz'aläm, k'im, aj, ch'ab'äq.



# RUKAJ TANAJ

Ri nutijob'äl

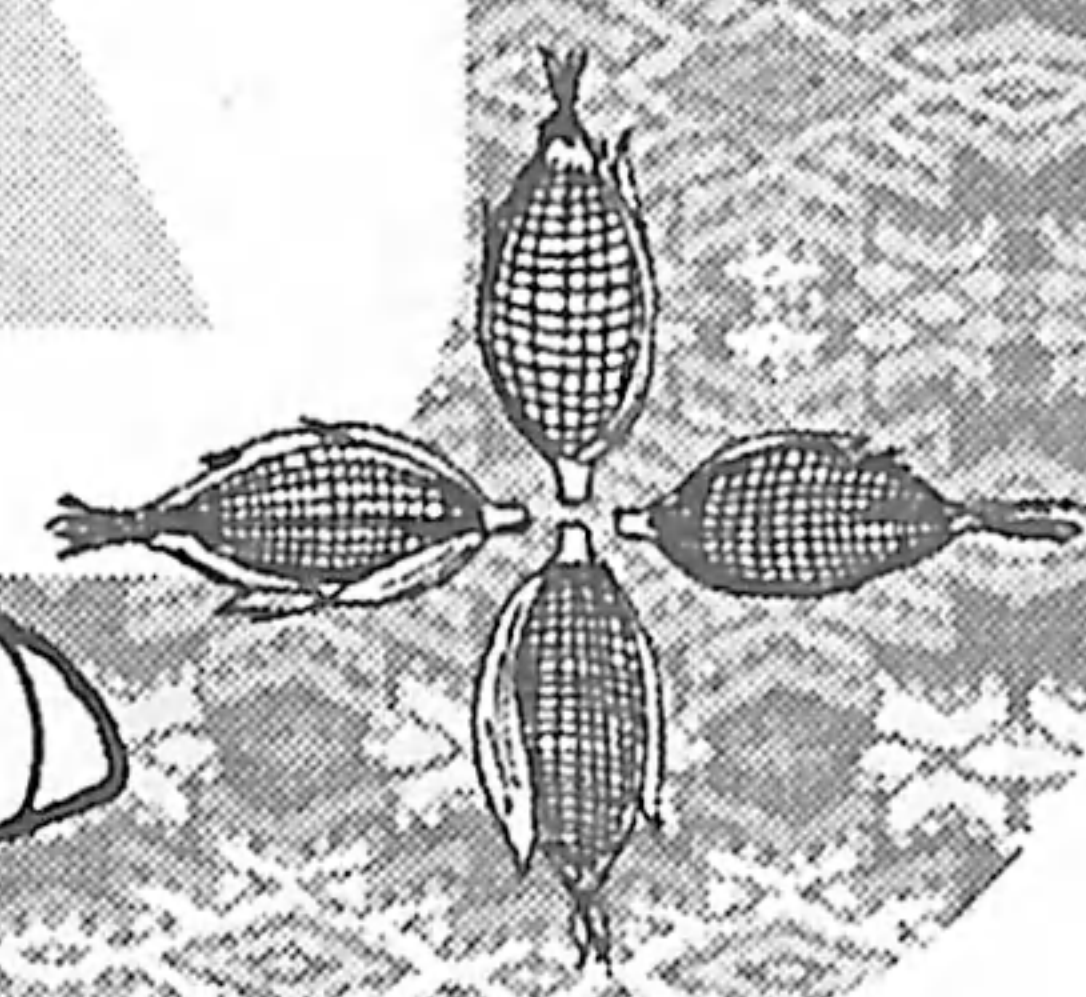
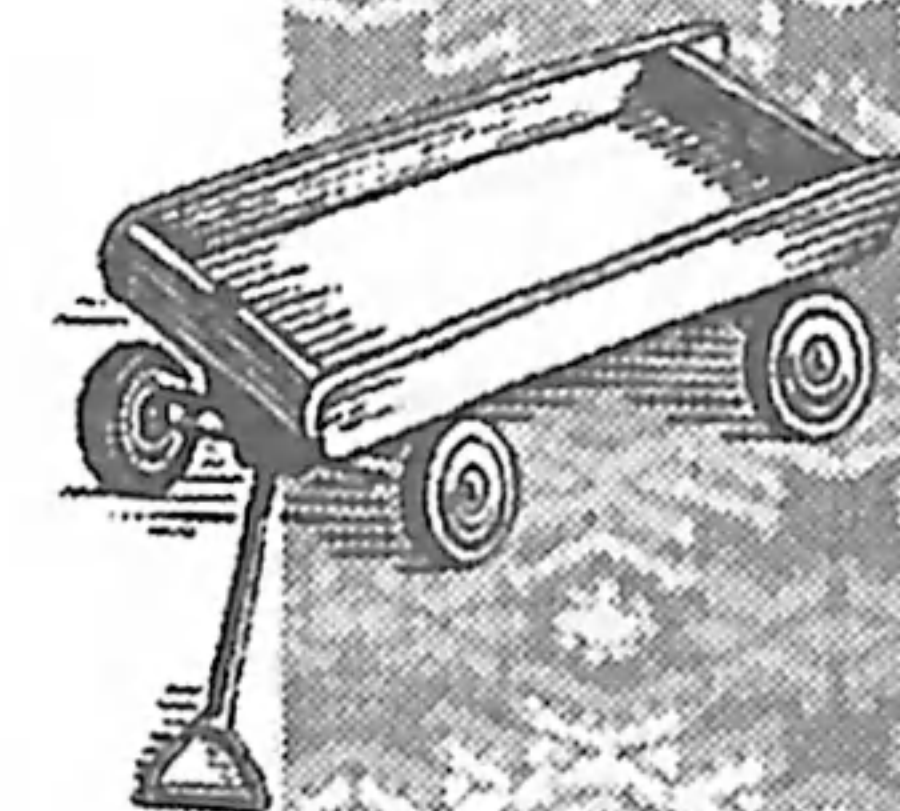
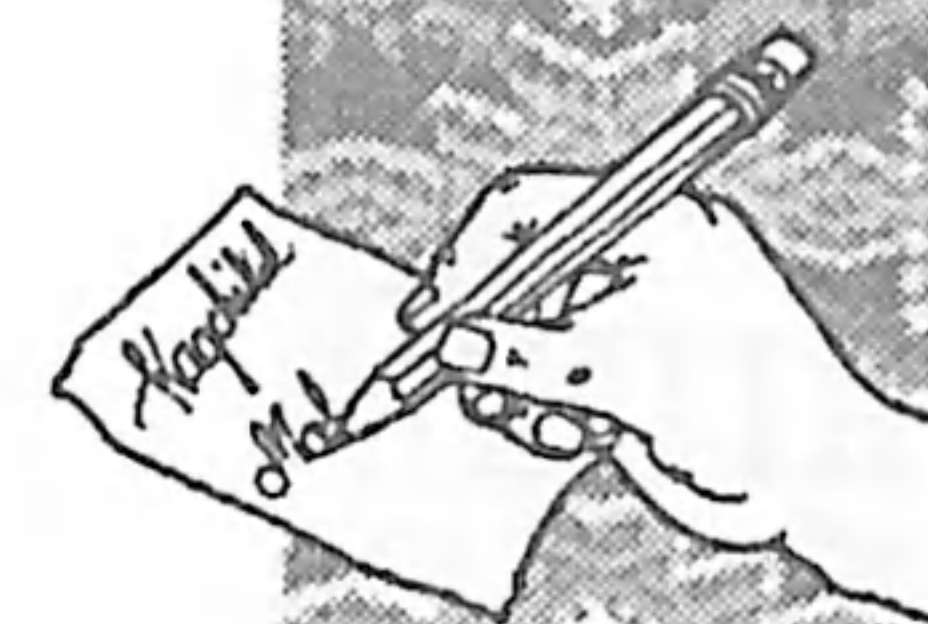

Ri etamanik nuq'i' ri tijoxel:

Nch'ob'on chi rij ri utziläj na'oj nretamaj pa tijob'äl.  
Nch'ob'on chi rij ri rejqalem ri tijob'äl pa qak'aslem.  
Nretamaj ntzizon pa ruwi' ri wachinäq e k'o pa tijob'äl.

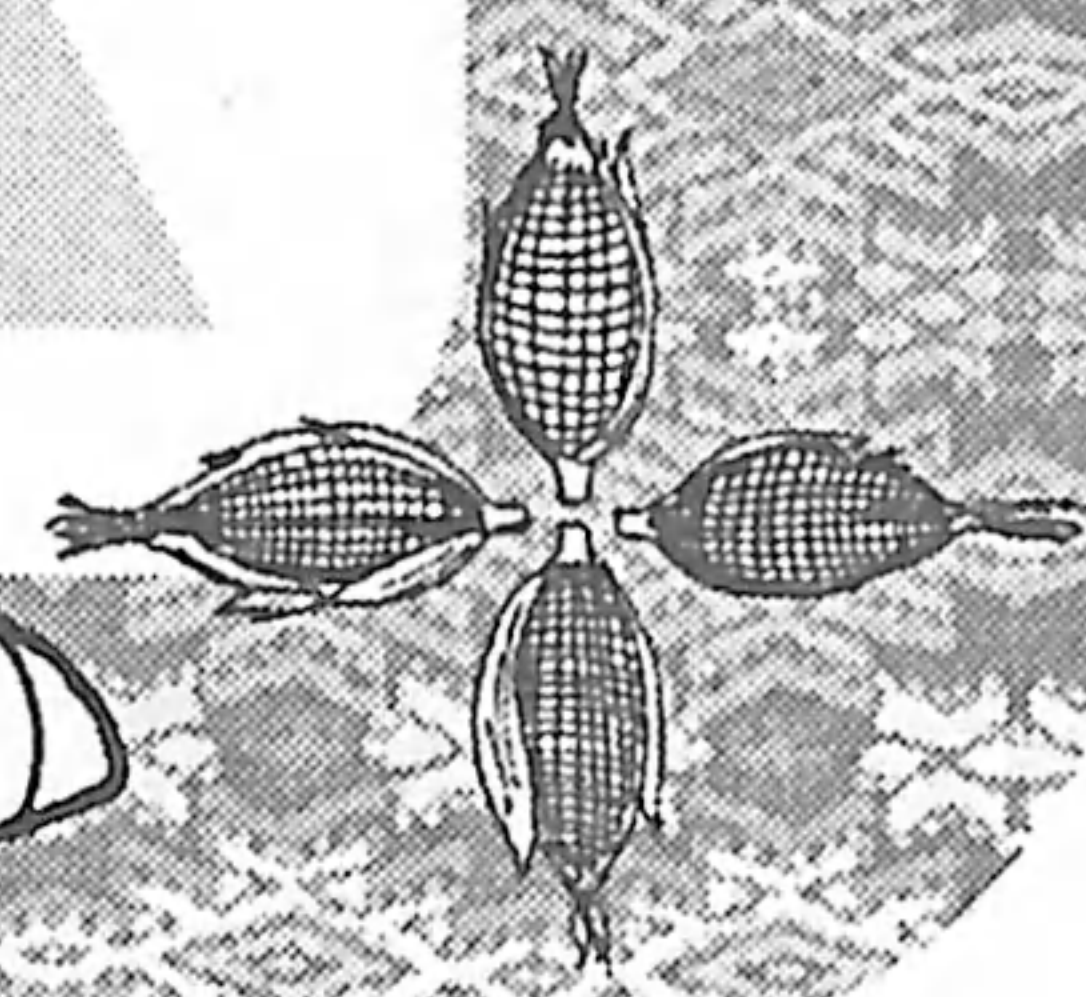

# RI QATIJOB'ÄL



Ri Xinwetamal

Kojsamäj pa kaka'.

Tqab'ana' rachib'äl ri qatijob'äl.

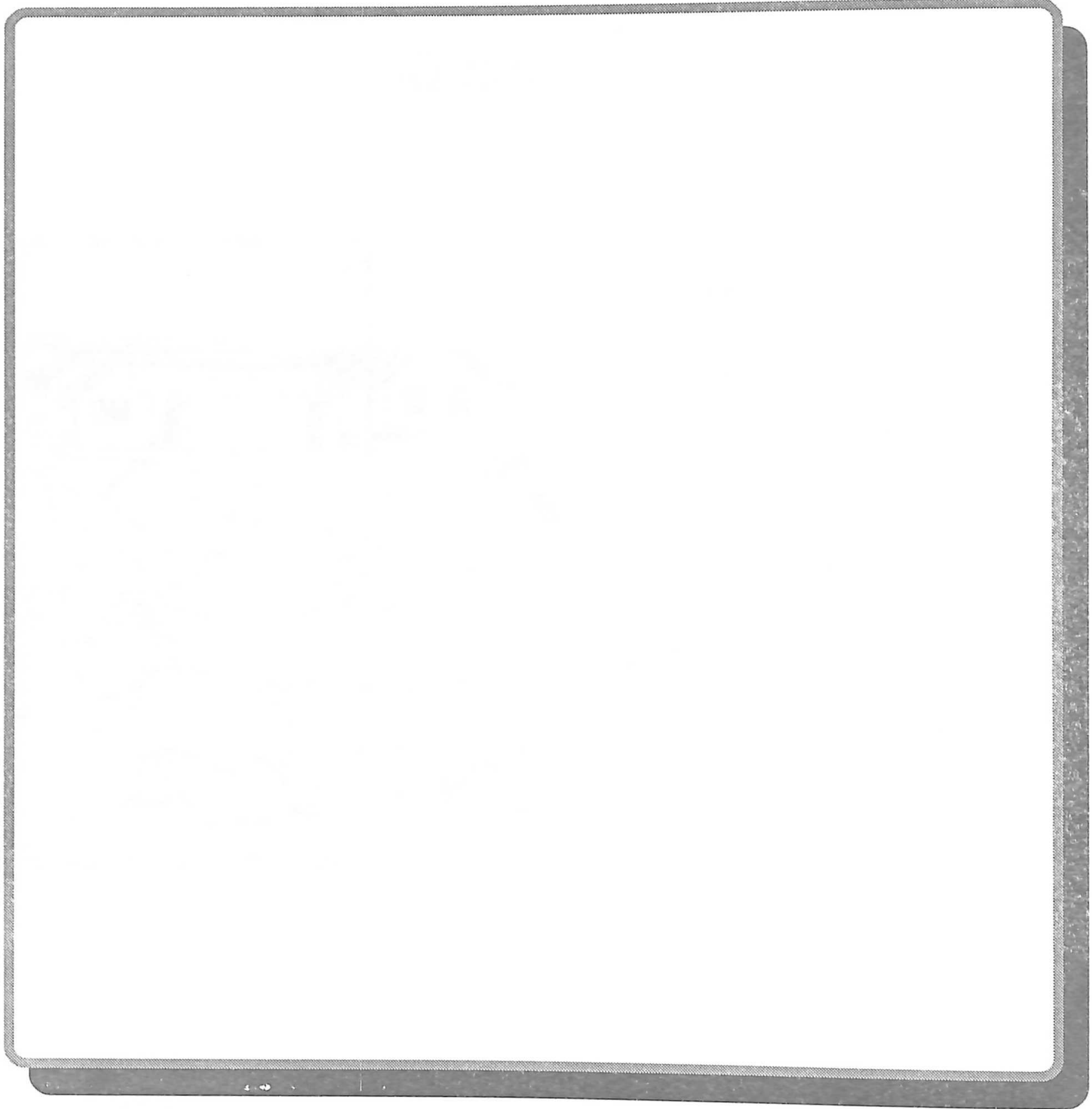
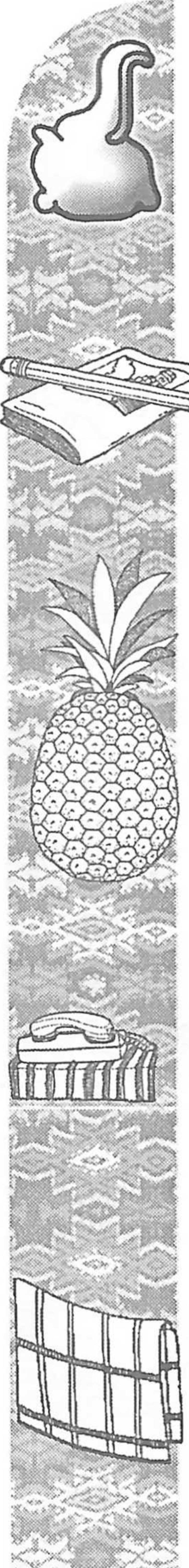

Soloj Samaj:

Ri tijonel nuya' chi kiwäch ri tijoxela' jun ruxaq wuj, chuqa' oxi' kaji' b'onijuxb'äl richin nkib'onij ri achib'äl.

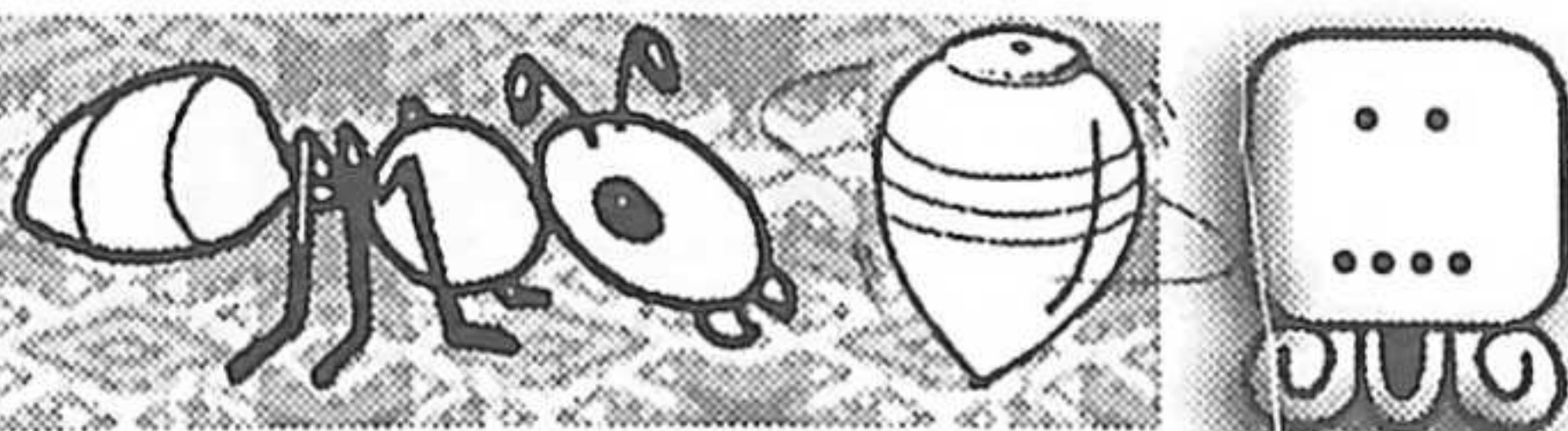

# Ri wachinäq e k'o pa tijob'äl

Kojsamäj pa qayonil: Tqaya' kib'i ri achib'äl

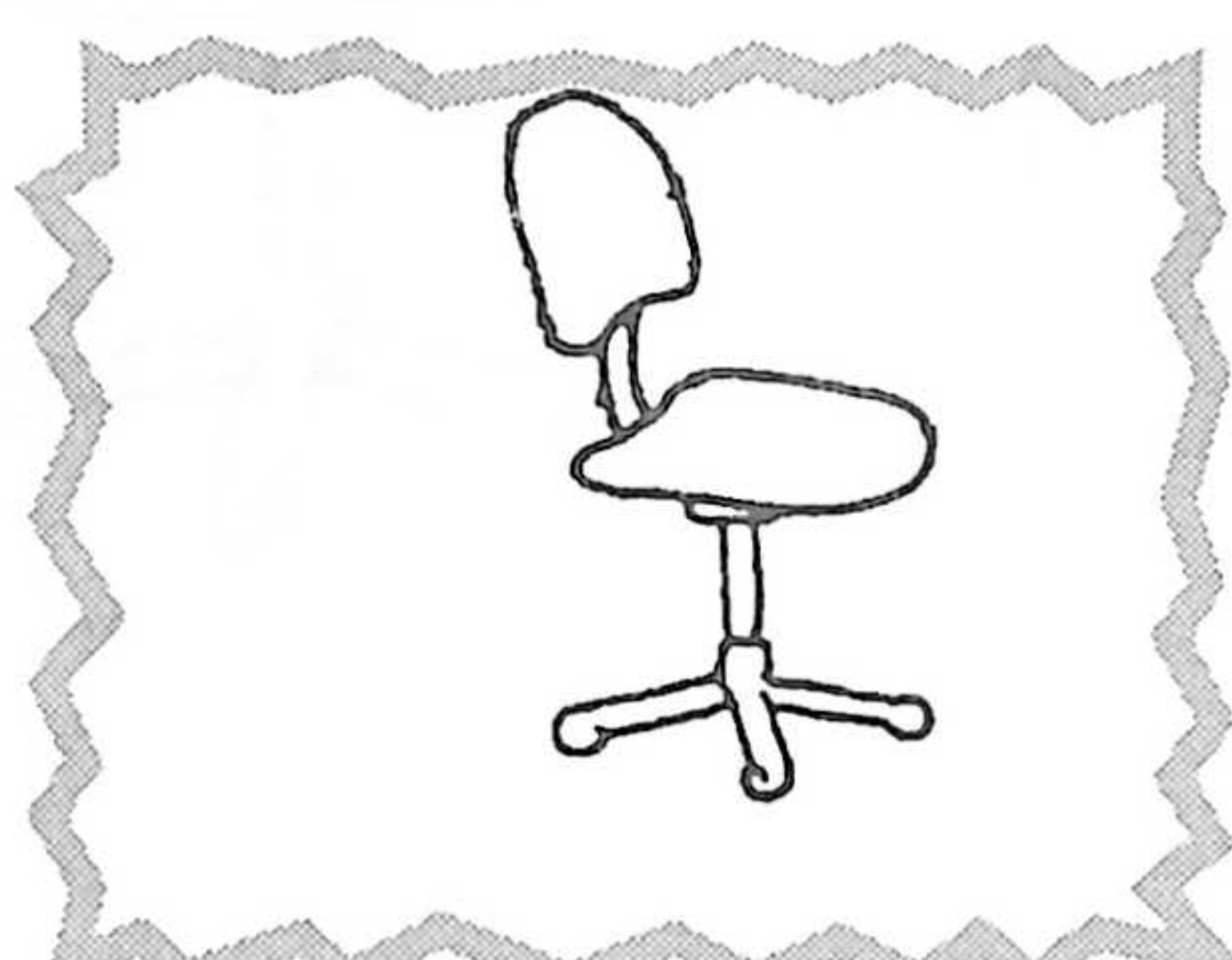
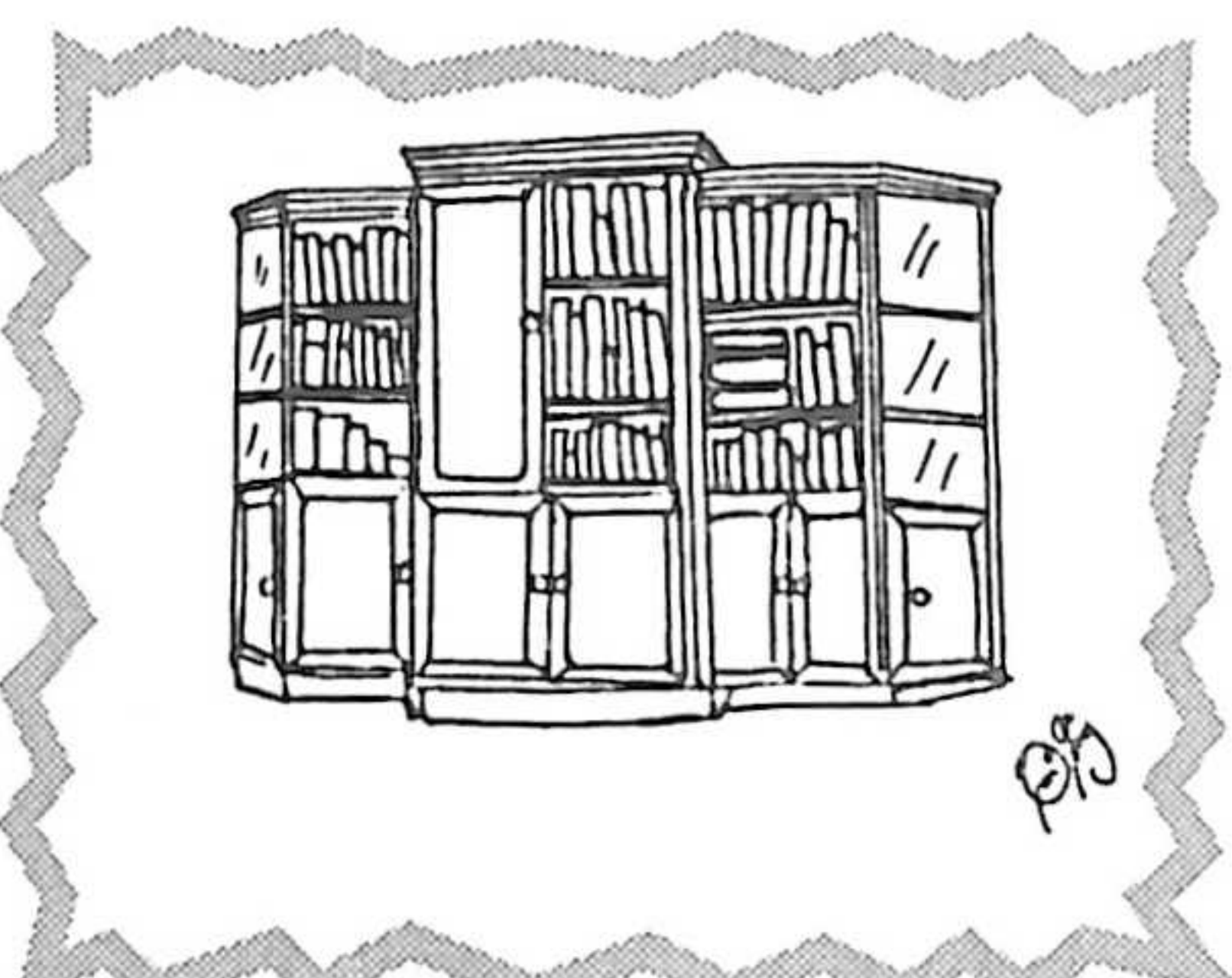
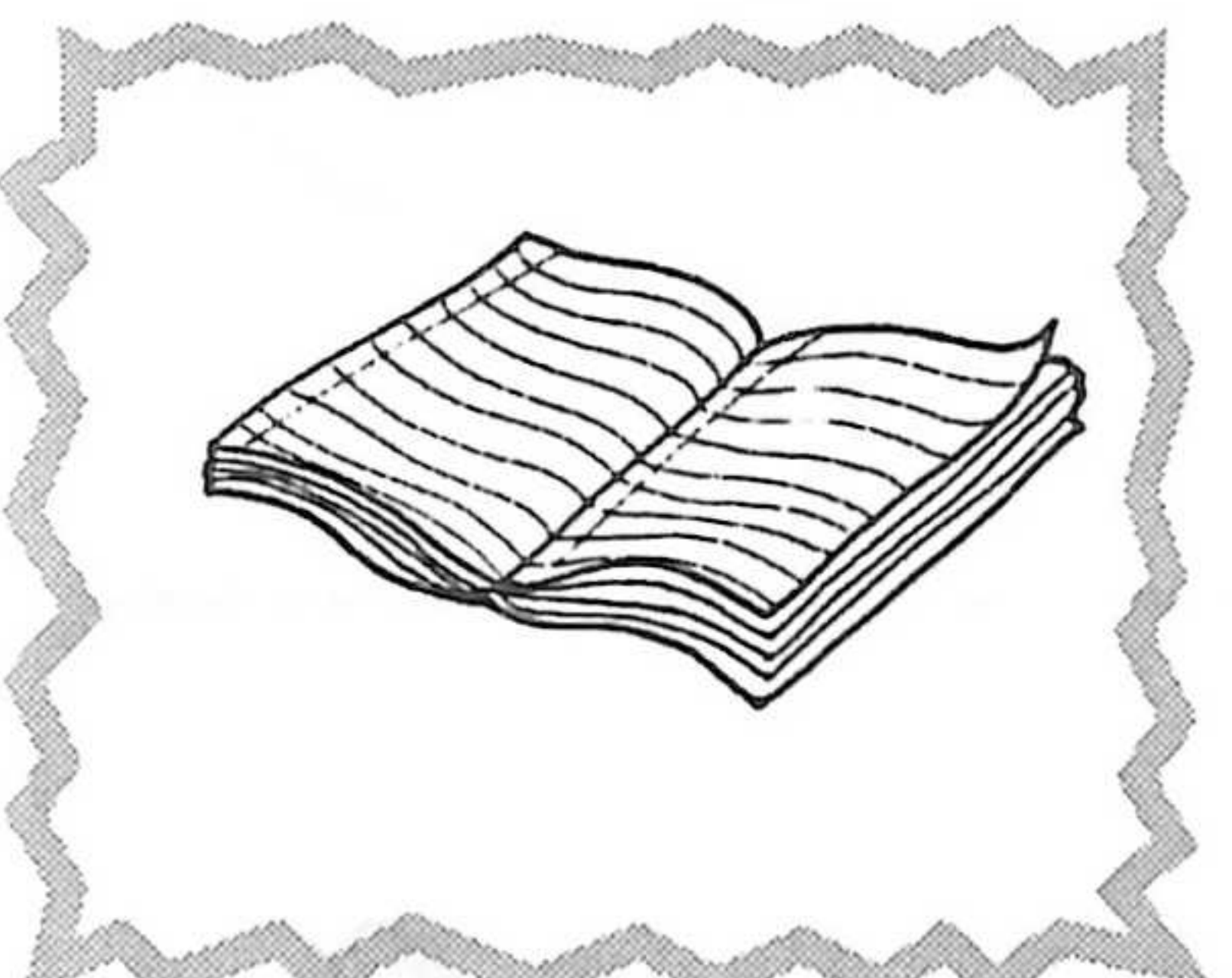
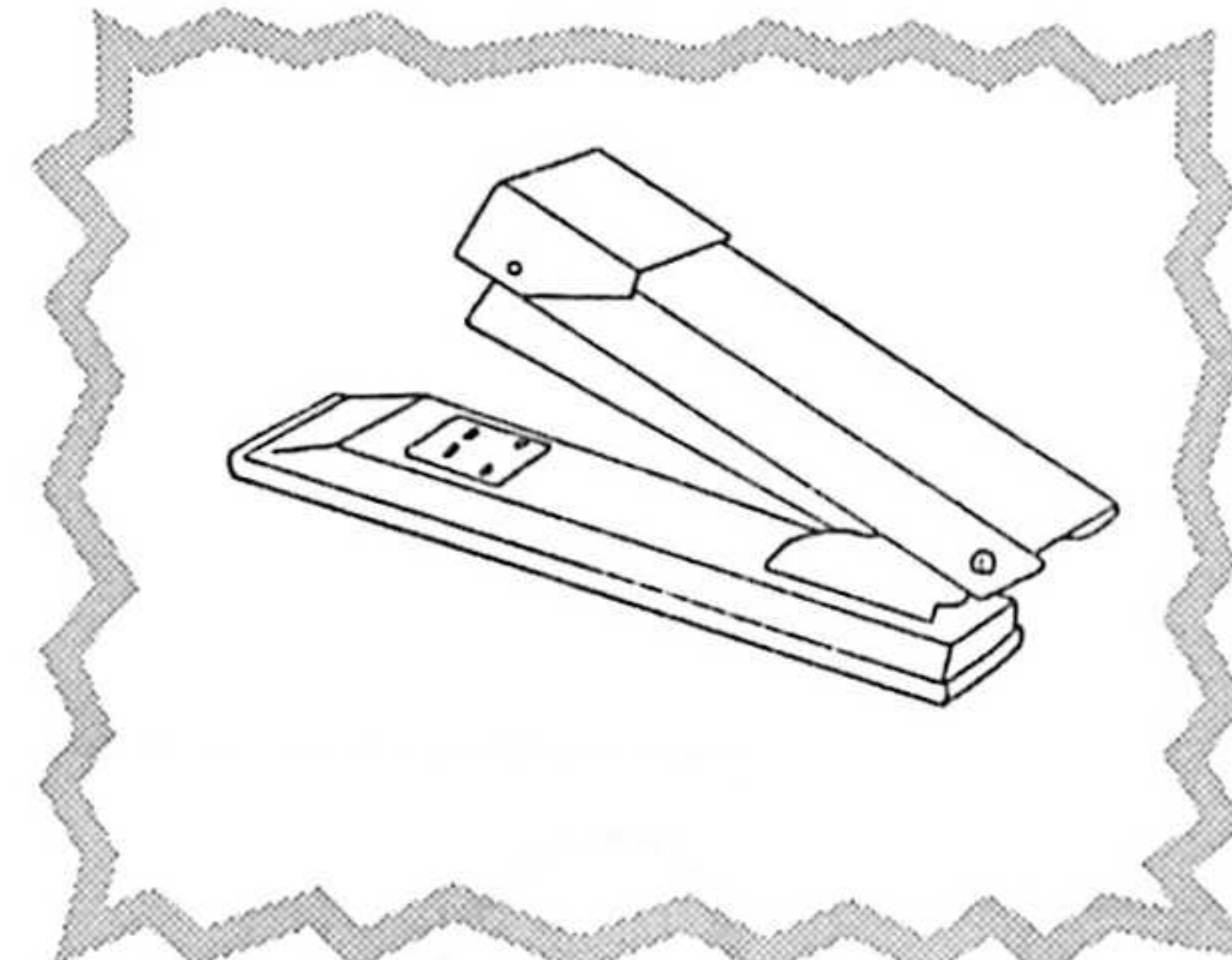
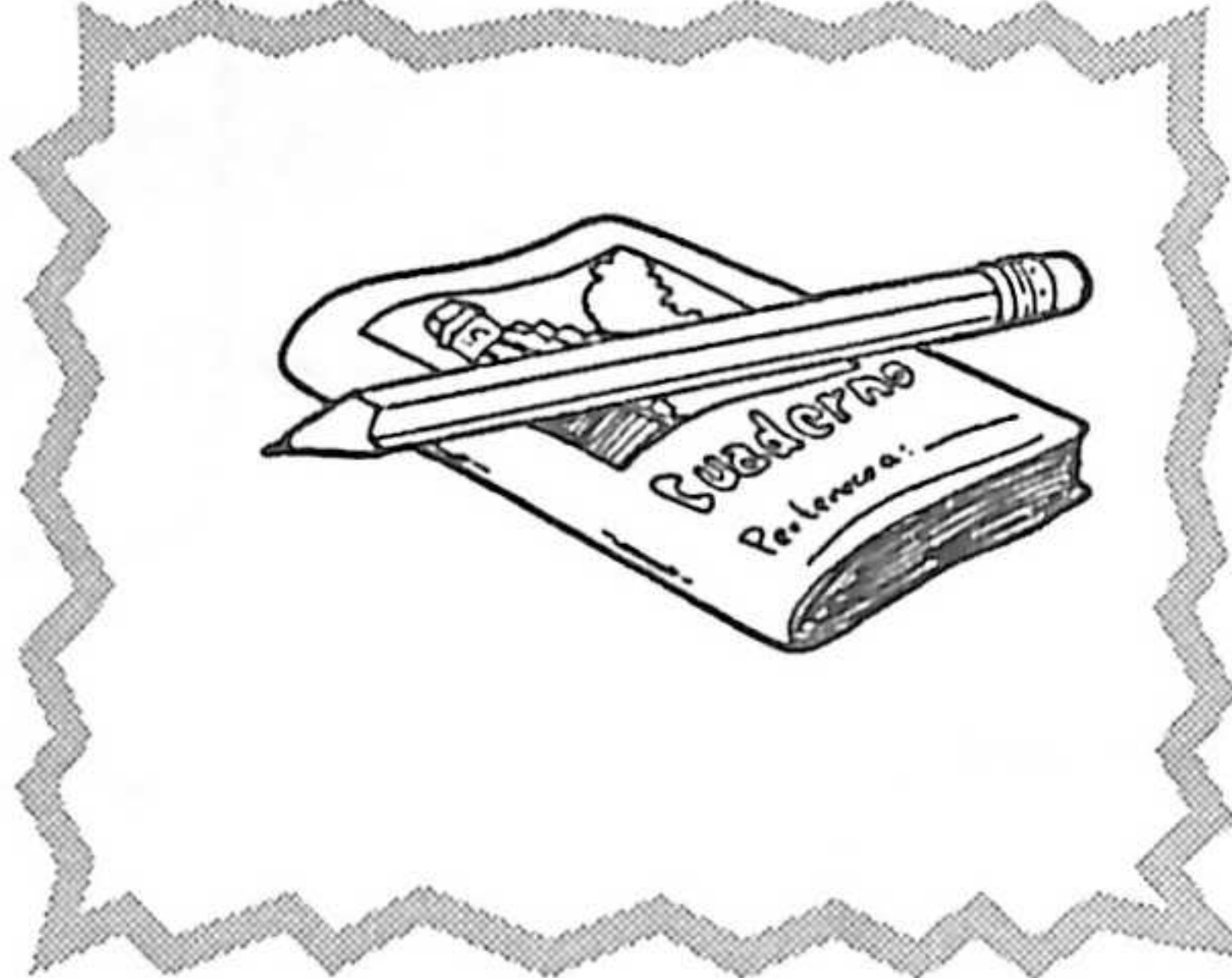
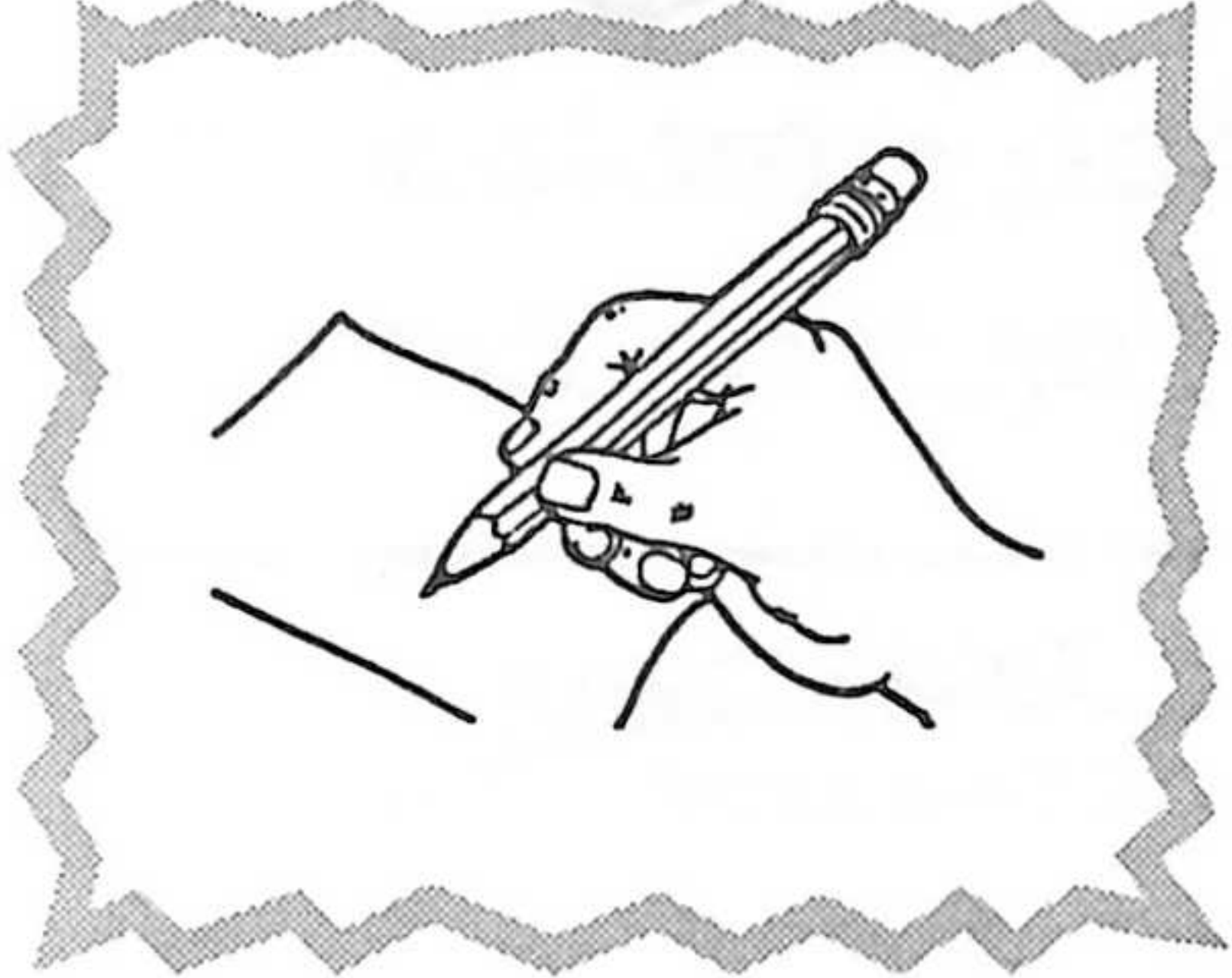

Ri tijoxela' fikirel nkib'än ri taq achib'äl pa taq nima'q wuj, richin ye'etz'an rik'in.

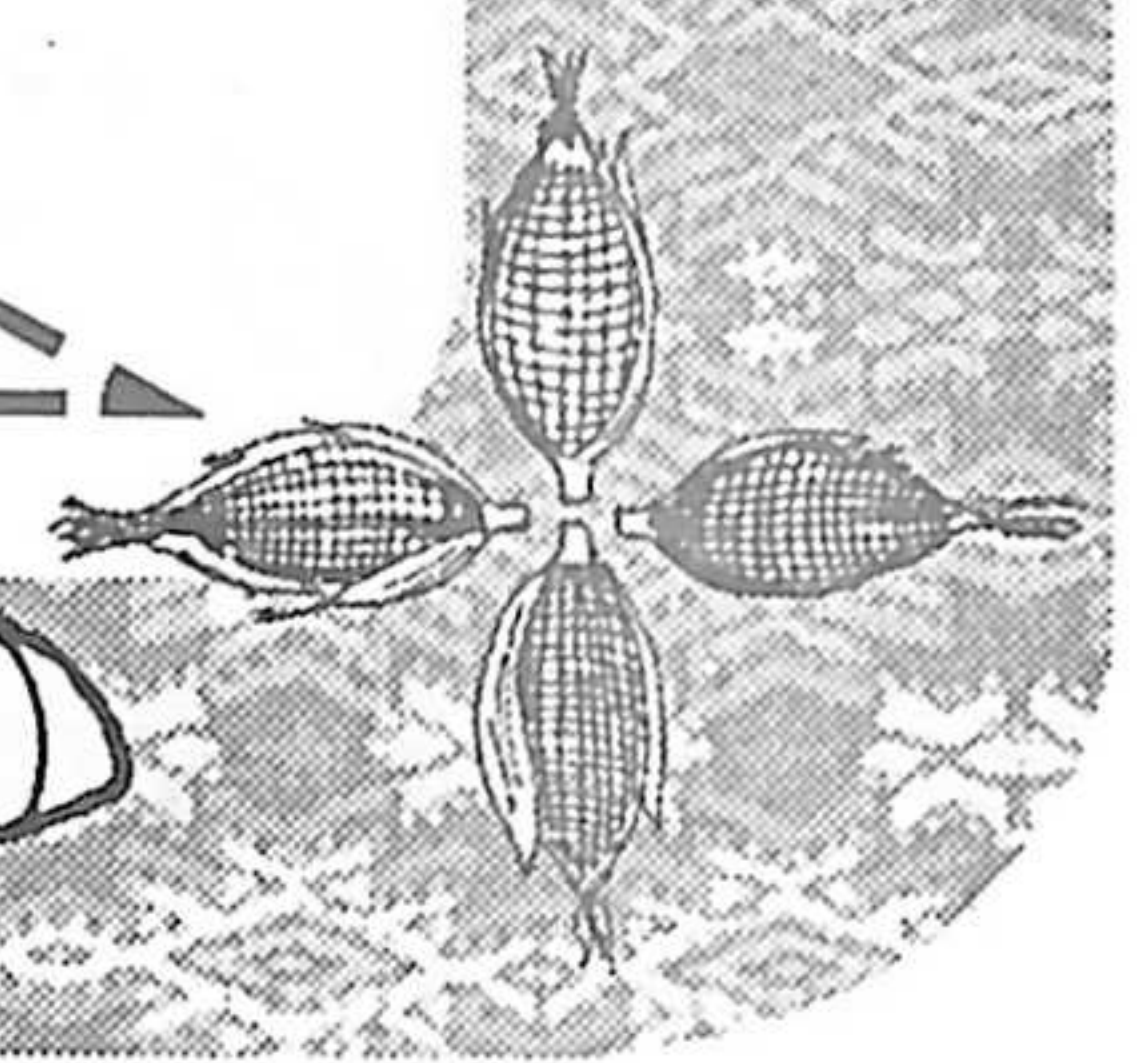

# Kojtzijon

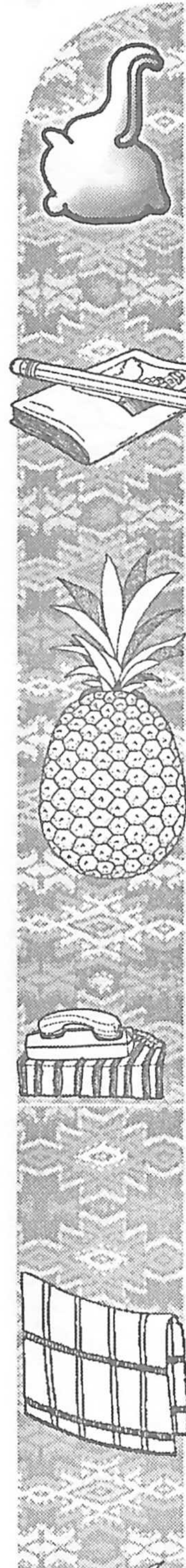

nu-  
a-  
ru-  
qa-  
i-  
ki-

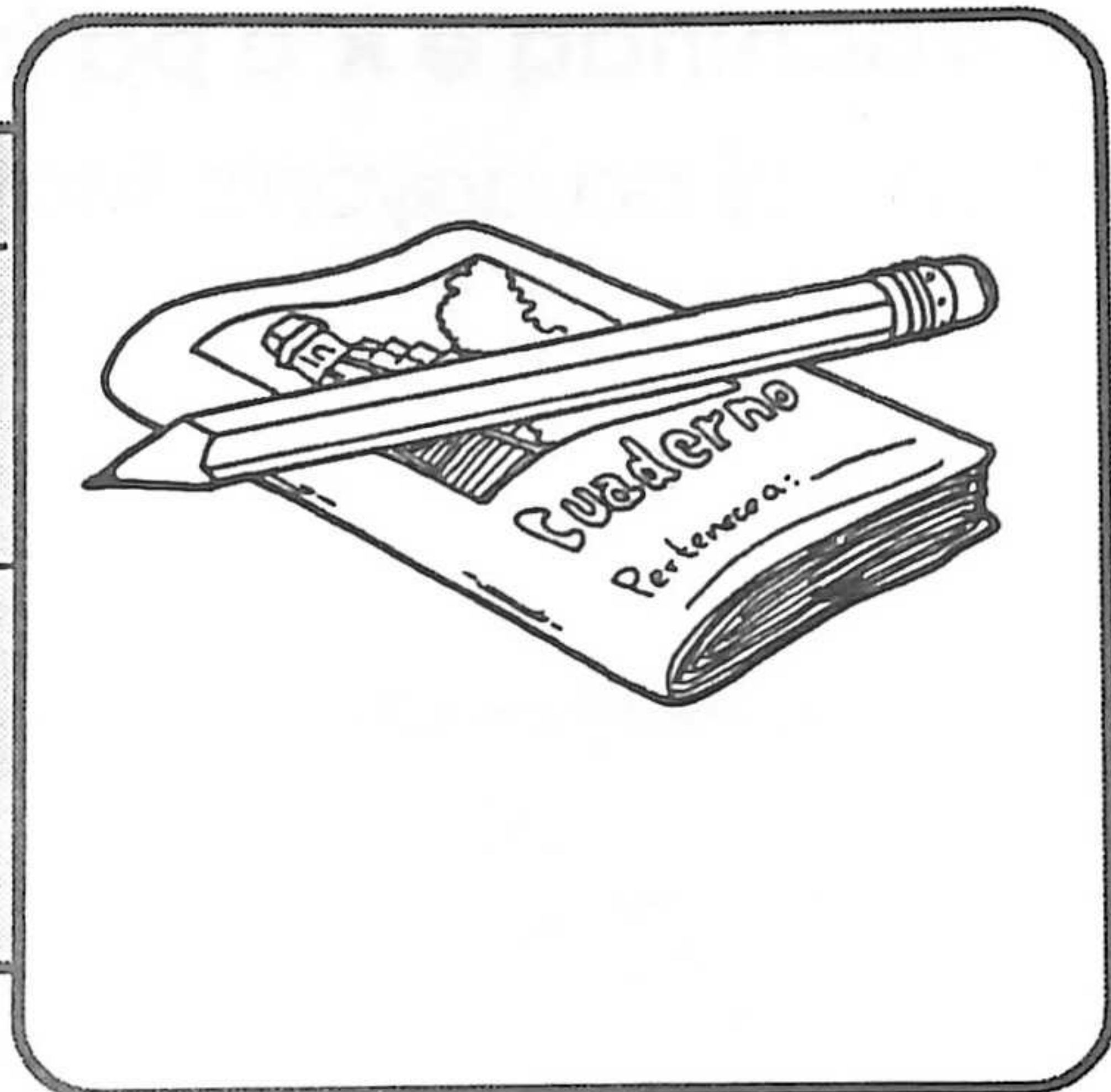

Tz'ib'awuj

nu-  
a-  
ru-  
qa-  
i-  
k-i



ch'akät

nu-  
a-  
ru-  
qa-  
i-  
k-i

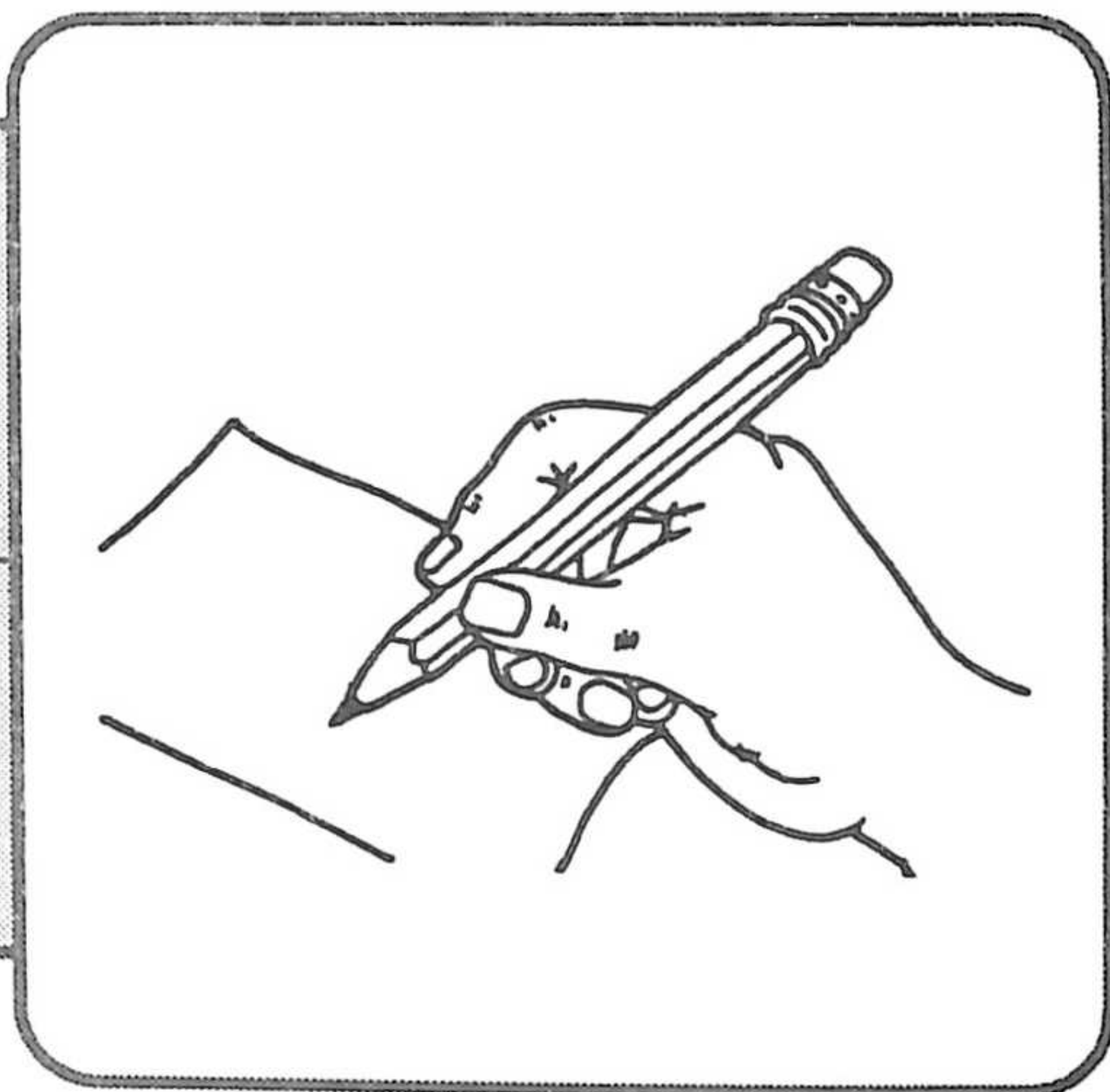

Tz'ib'ab'äl

Ri tijoxela' yetzijon pa jalajöj ramaj pa ruwi' ri taq achib'äl.

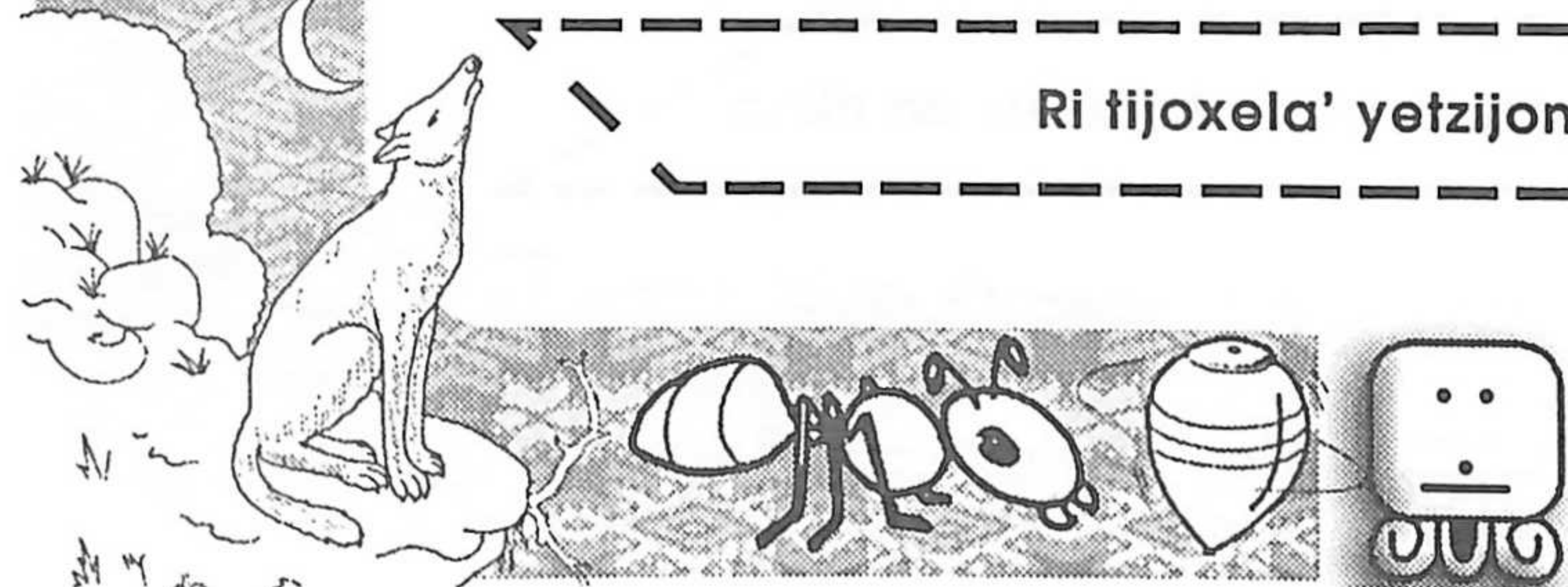

# Pach'un tzij

Yalan tik'asäs ri qatijob'äl.  
Ri qatijob'äl ruka'n qochoch.  
Ri qatijob'äl achi'el qate' qatata'.  
Nuk'ut chi qawäch utziläj taq na'oj.



## Ri ninwetamaj pa tijob'äl

Kojsamäj pa kaka': Tzijenem chi rij ri qatijob'äl.

(Nchapo el) lxchel:

1. Xsaqër Ajpu'
2. K'iy na'oj nqetamaj pa tijob'äl peja Ajpu'.
3. Achike awetaman chik pa tijob'äl rat Ajpu'.
4. Rin chuqa' wetaman chik ninsik'ij ruwawuj. Matyox chawe.

Ajpu':

1. Xsaqër lxchel
2. Ja' lxchel jeb'ël na'oj nqetamaj.
3. Rin wetaman chik ninsik'ij wuj. Rat achike awetaman chik lxchel."
4. Jeb'ël ri' tiqaxik'a qi' junam

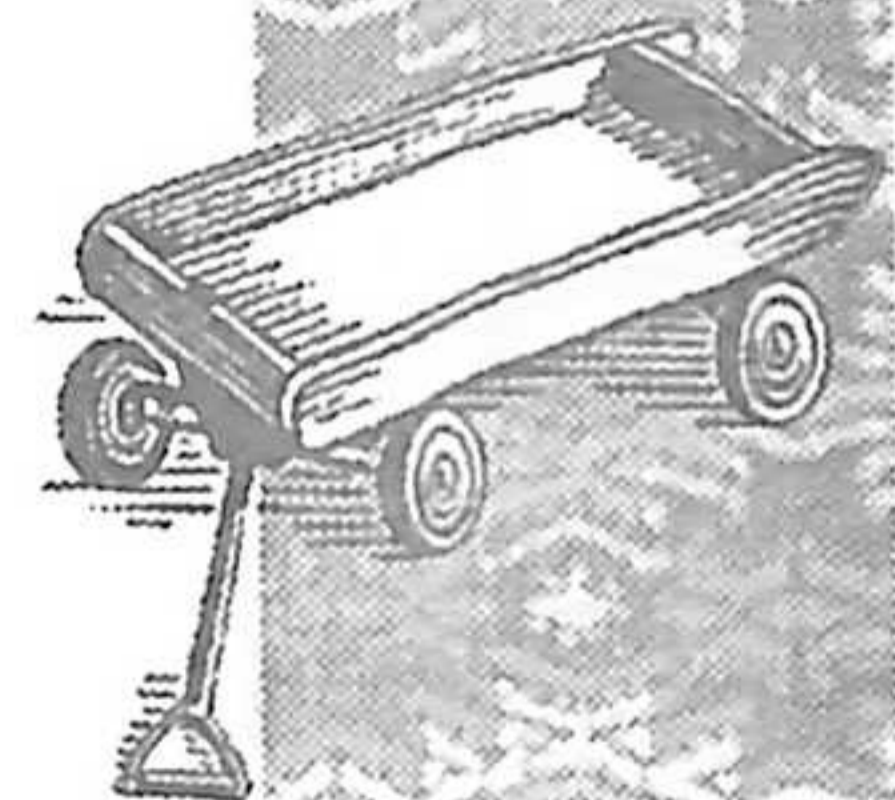
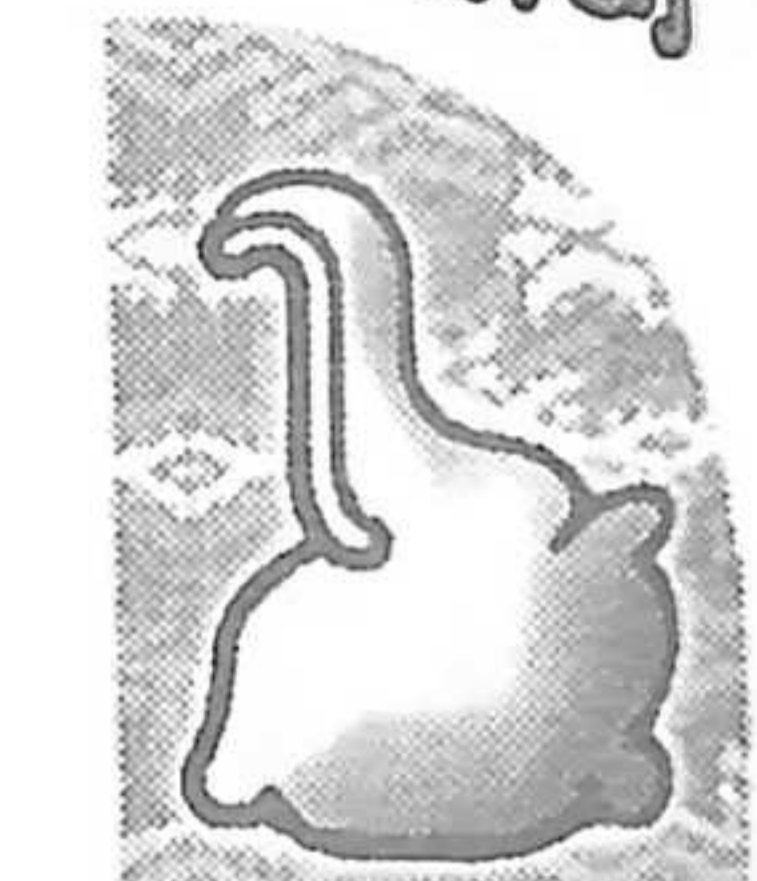

Ri tijoxela' tikirel nketamaj ri pach'un tzij, chuqa' ützt ketzjon pa ruwi' ri tijob'äl.

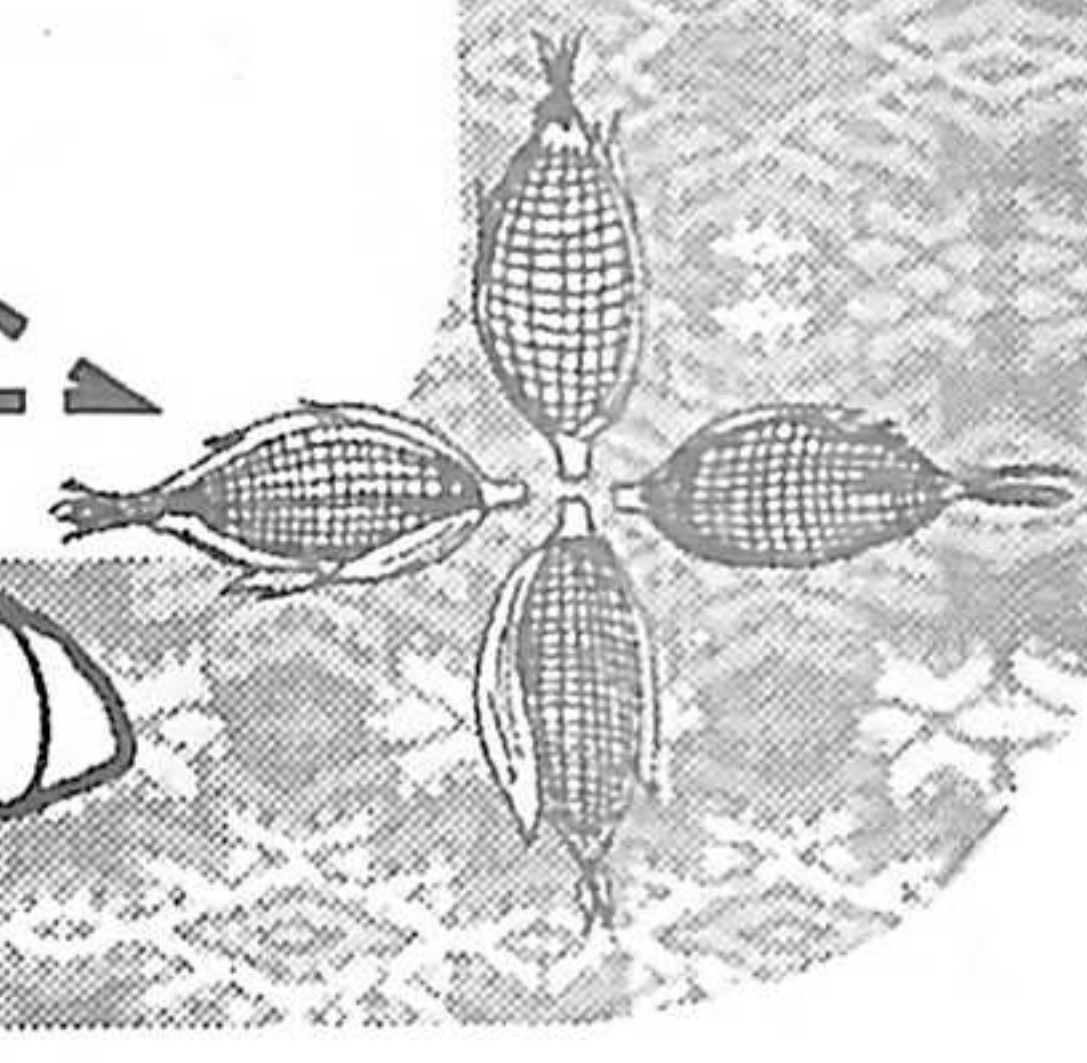
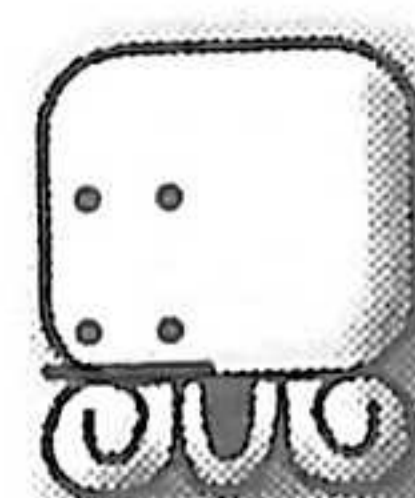



# Ri nwetamaj pa tijpob'äl



Ri Nwetamaj

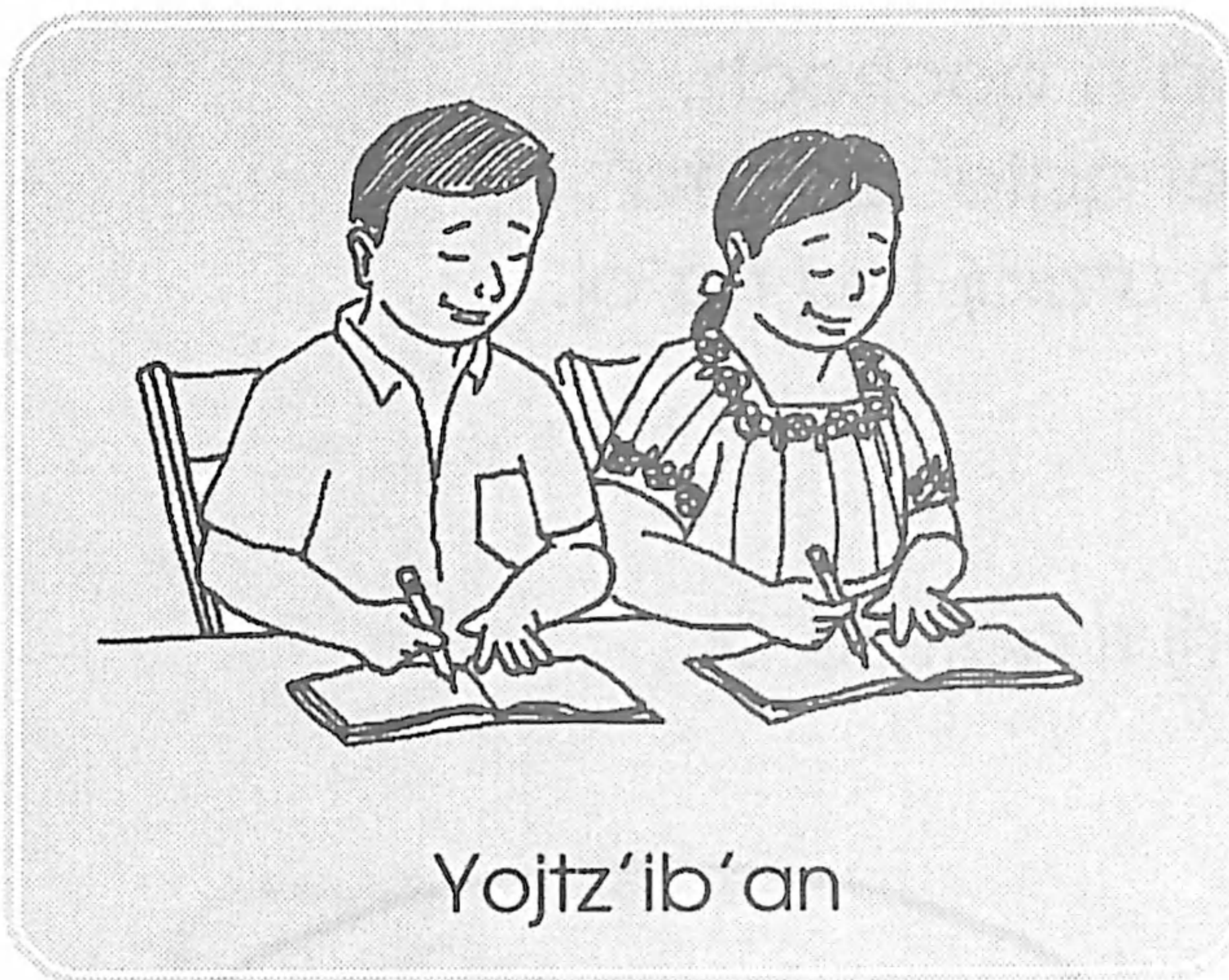
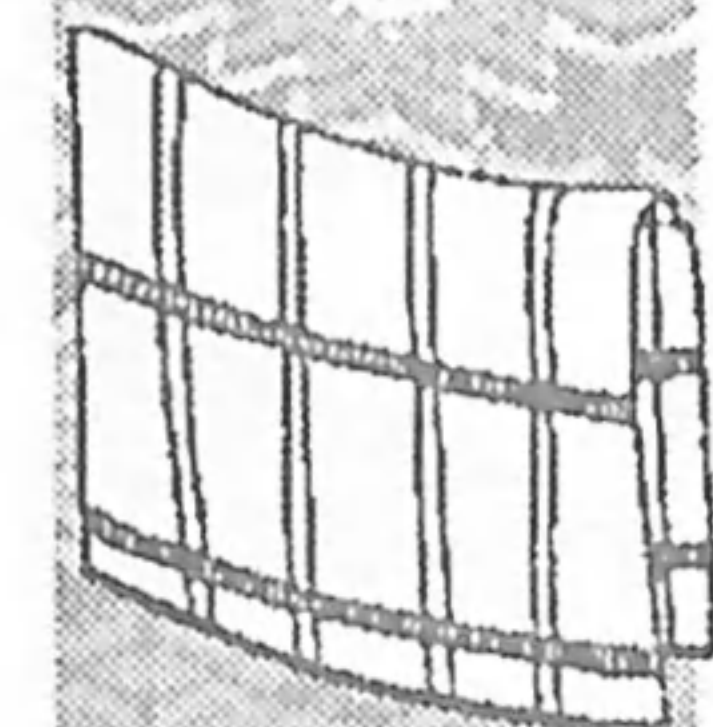

Yojtz'ib'an

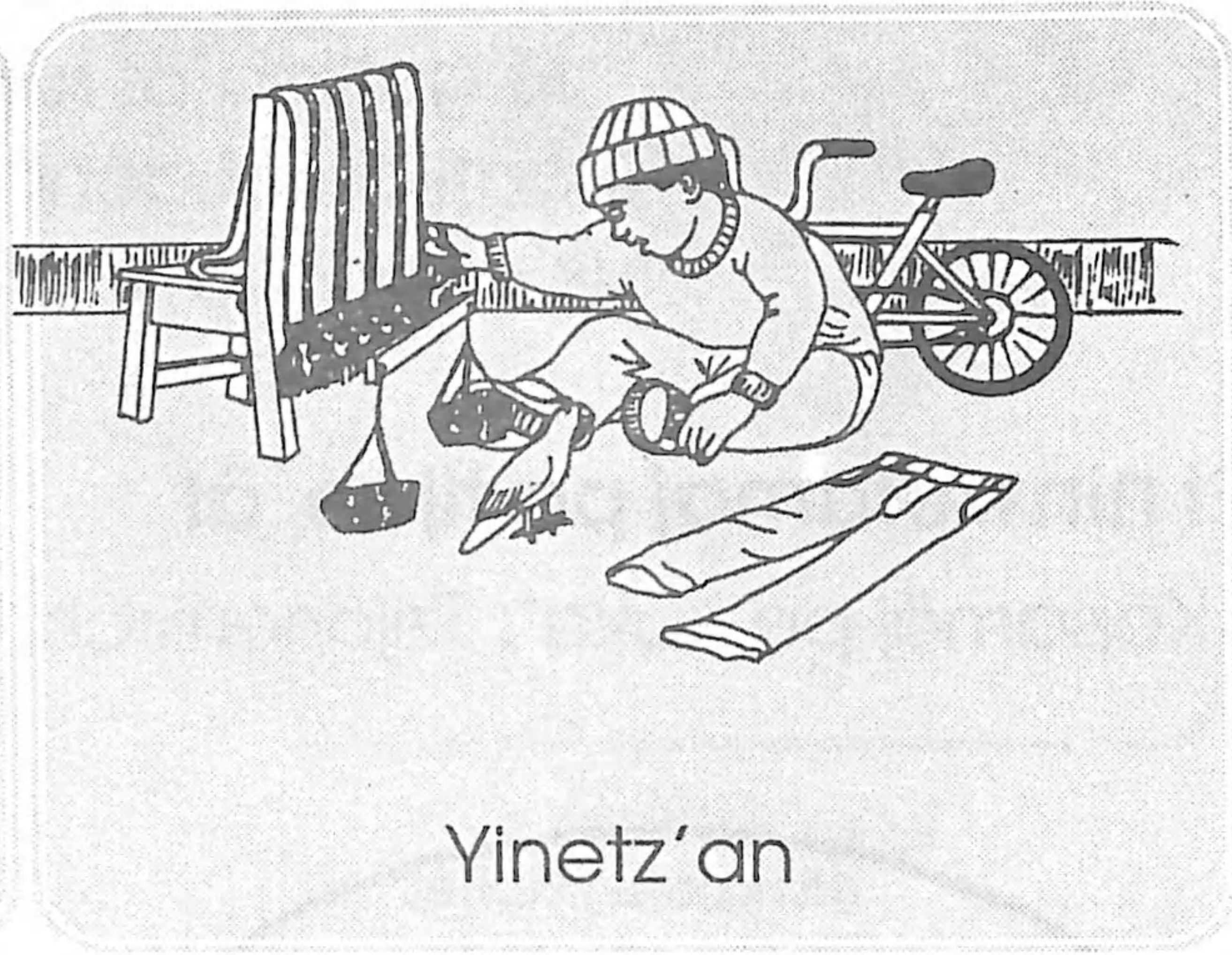

Yinetz'an



Yinajilan

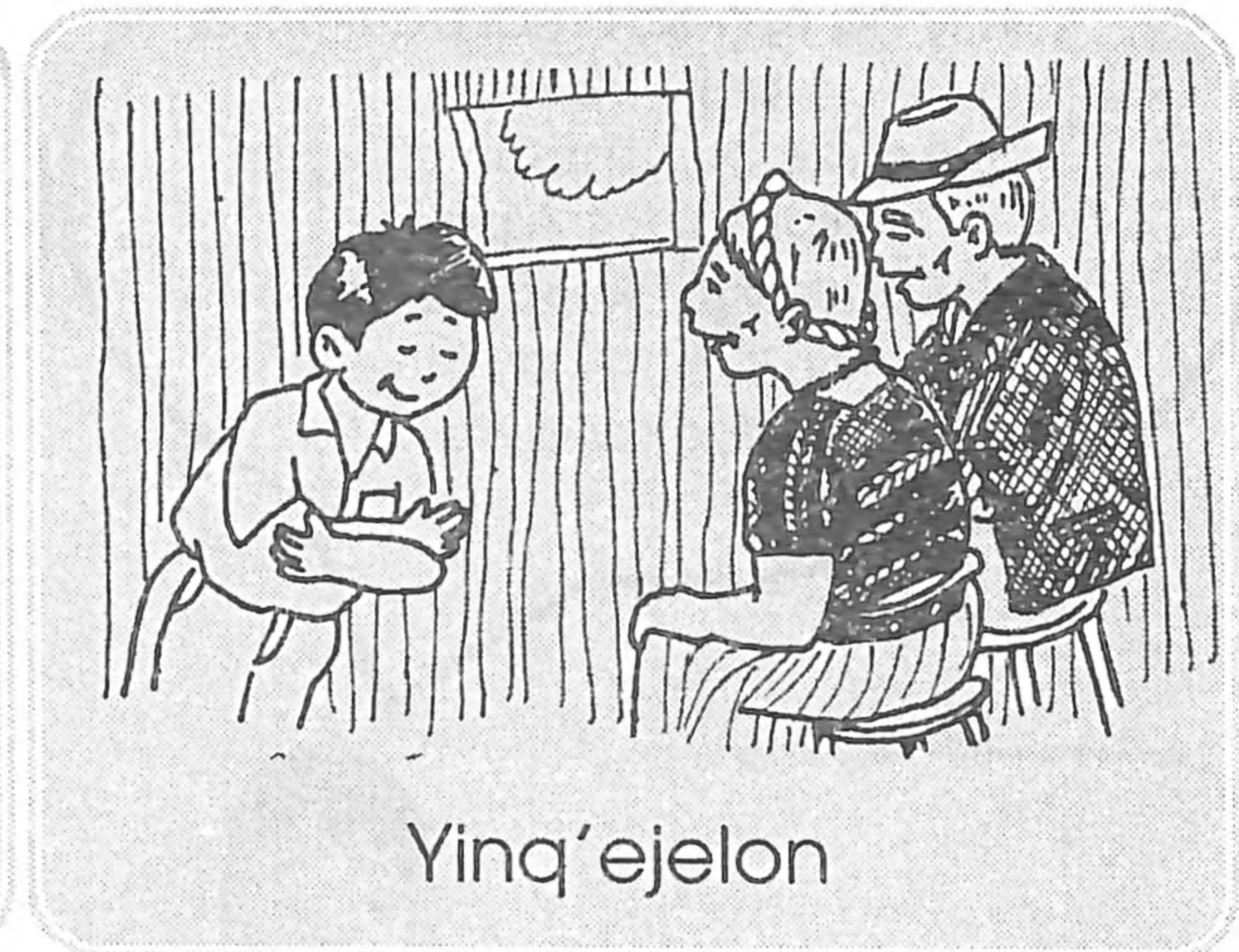

Yinq'ejelon



Yinb'ixan



Nqapach'uj tzij

Ri tijonel tikirel tub'ana' jalajöj etz'anem pa ruwi' ri achib'äl.

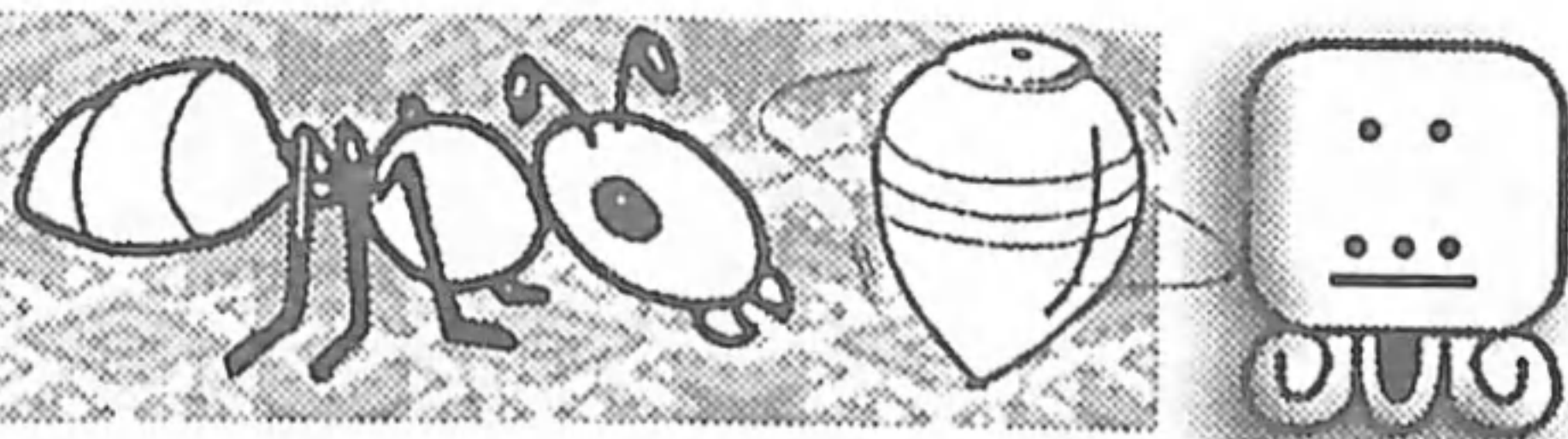

# Kojtzijon

Nb'ixan ri tijonel



Nusik'ij ruwäch wuj ri tijoxel



Nub'ij pach'un tzij ri ixtän

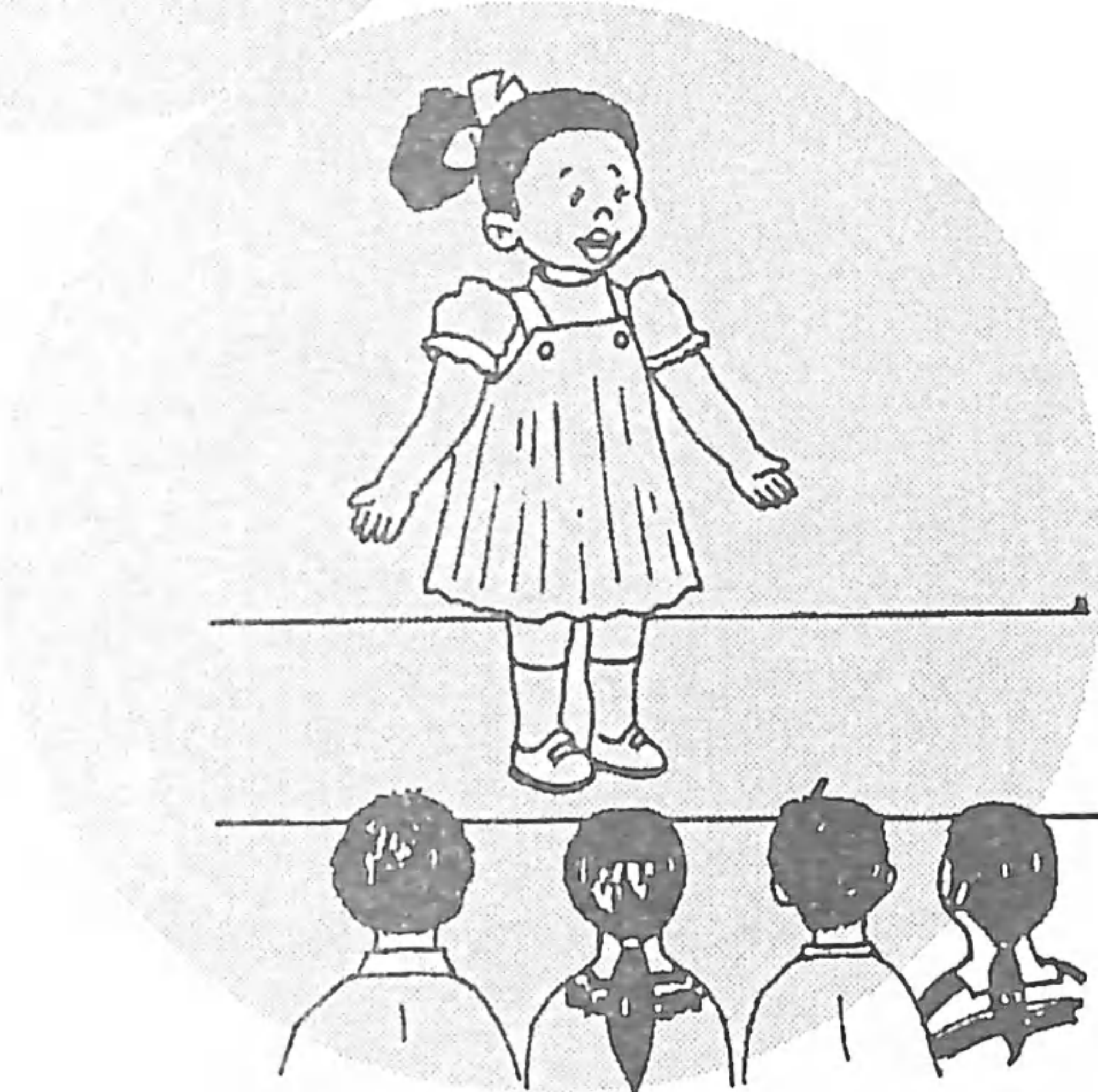

Achike nub'an ri tijonel.  
Achike nub'an ri tijoxel.  
Achike nub'an ri ixtän.



Pi Nwetamaj

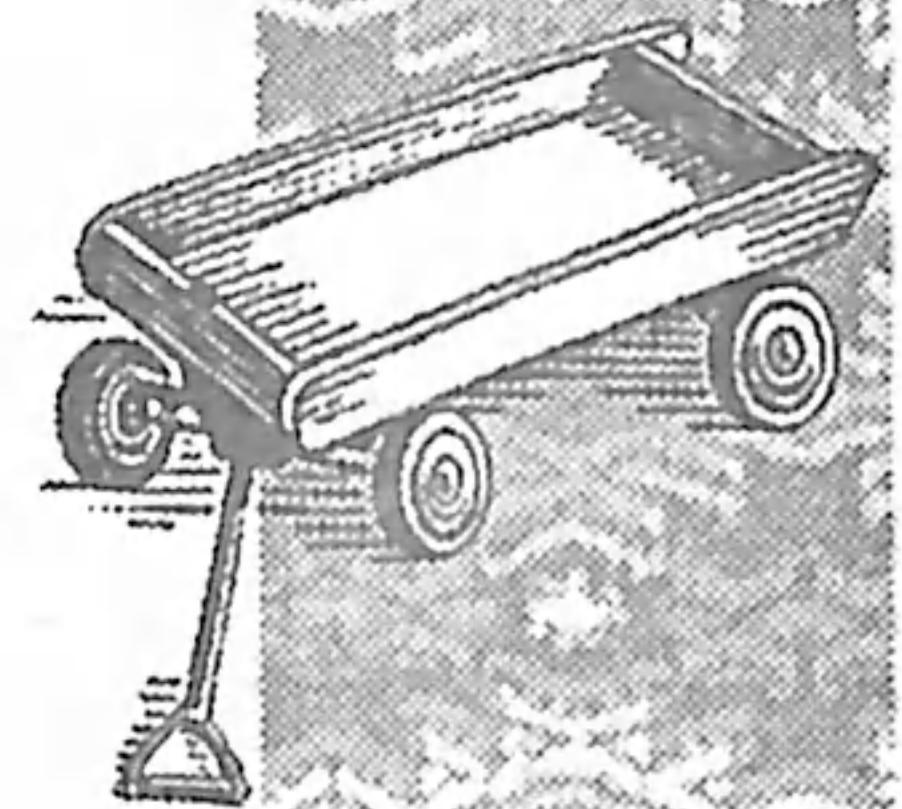
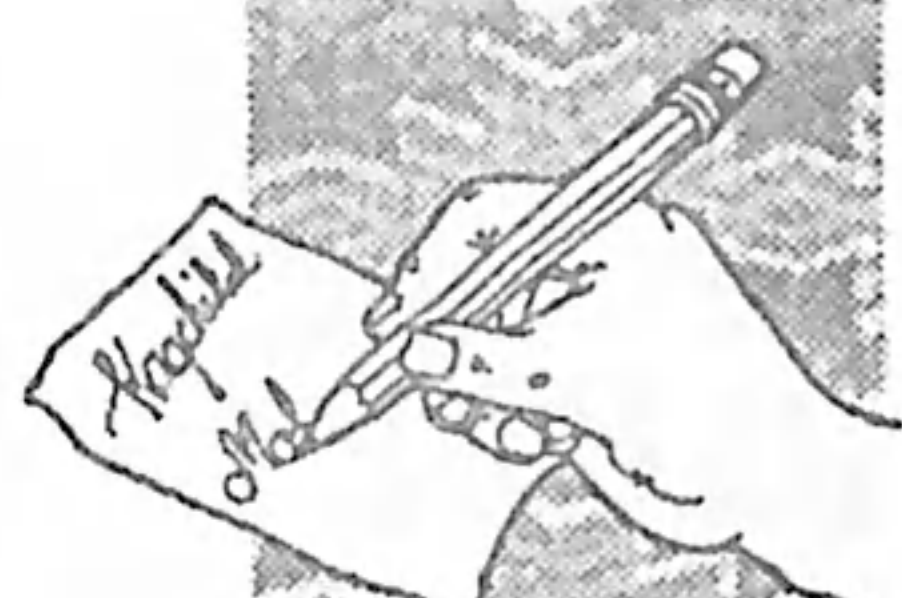

Tikirel nqetamaj ri tzij: ja' manaq.





Achike nub'än ri nutijonel

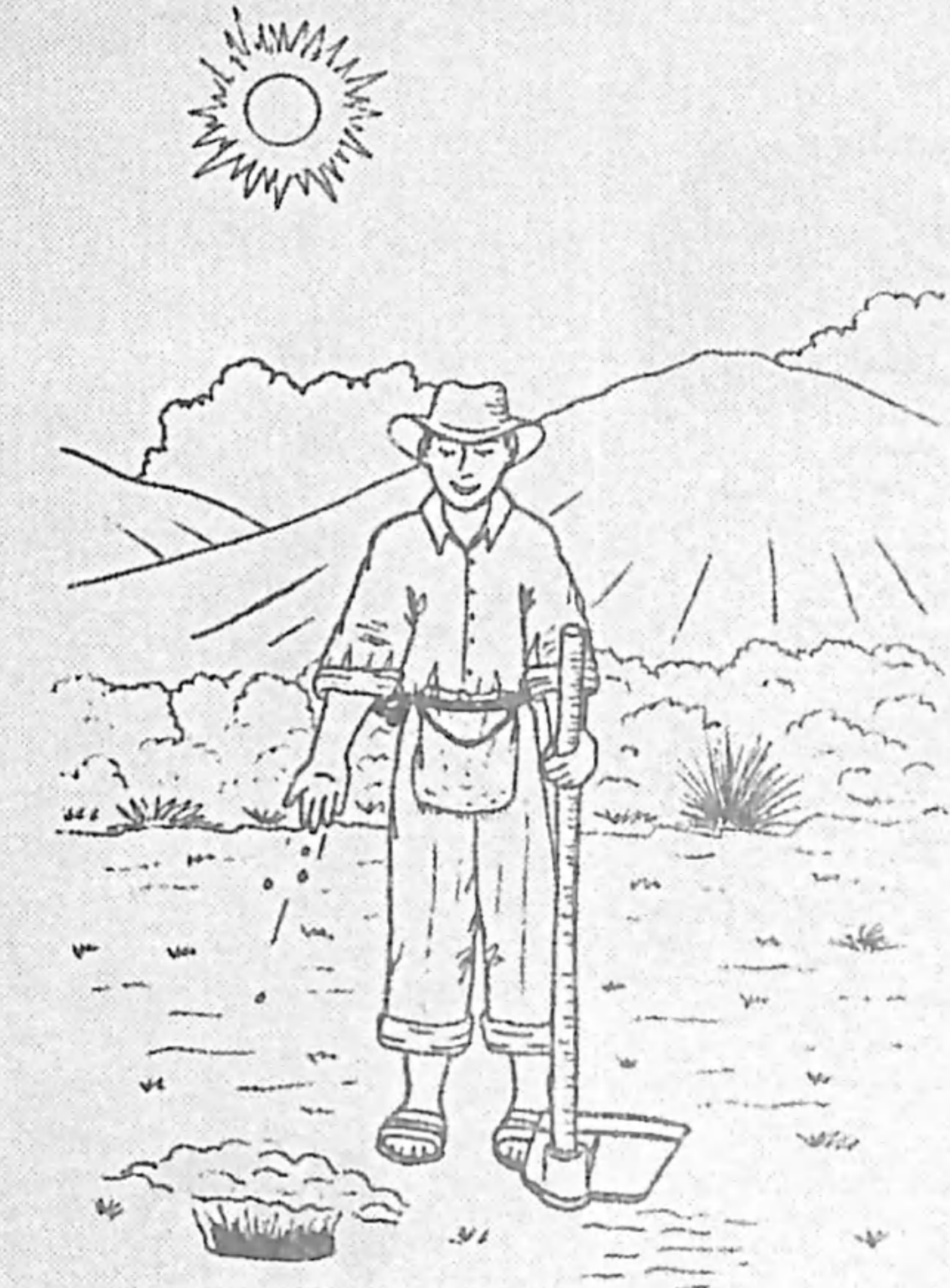
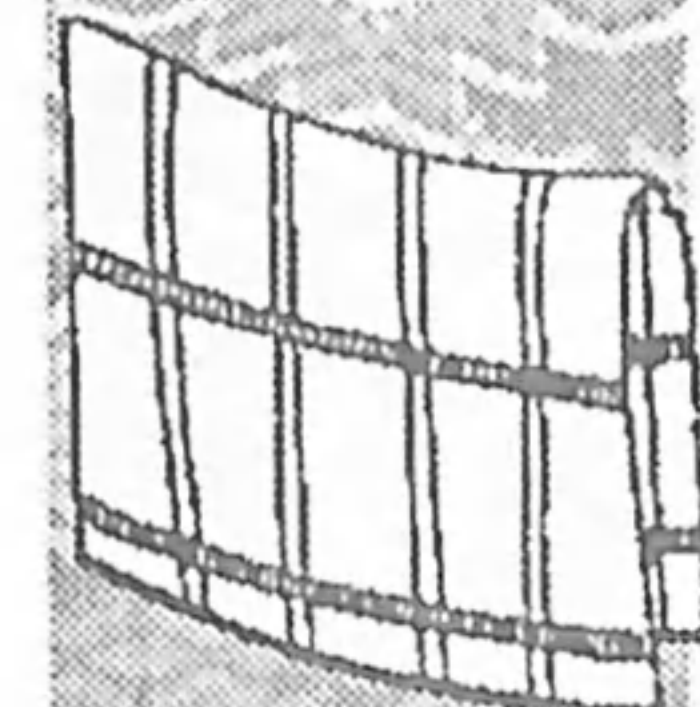
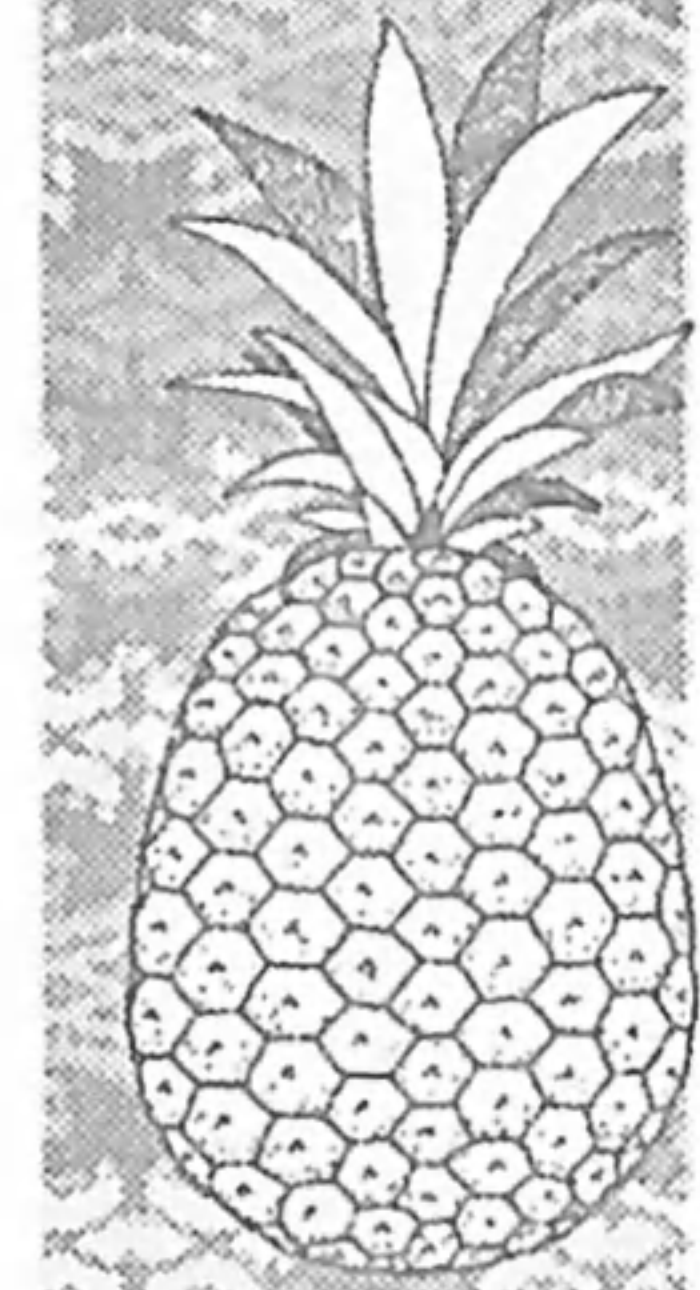

Achike nub'än ri nutata'



Achike nub'än ri nuchaq'

Tikirel nqakamuluj re taq tzij re' richin jeb'ël nketamaj ri tijoxela',  
chuqa' üt'z tkib'ana' jalajöj taq achib'äl chupam ri kitz'ib'awuj richin  
nketamaj pa rub'eyal.

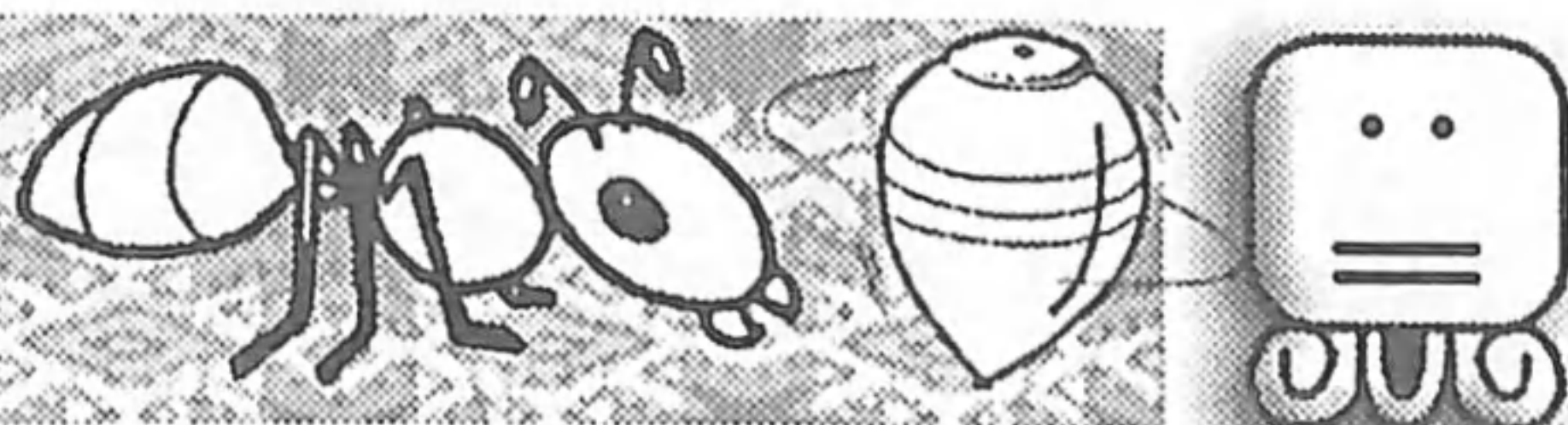

# K'utüy utzil



## Kojtzion

Xwan: Tab'ana' utzil  
ninqäj jub'a' ri asik'iwuj.

Ixkotz'i'j: üt k'a ja re' k'o

Xwan: Matyox chawe.

Ixkotz'i'j: majun nub'an

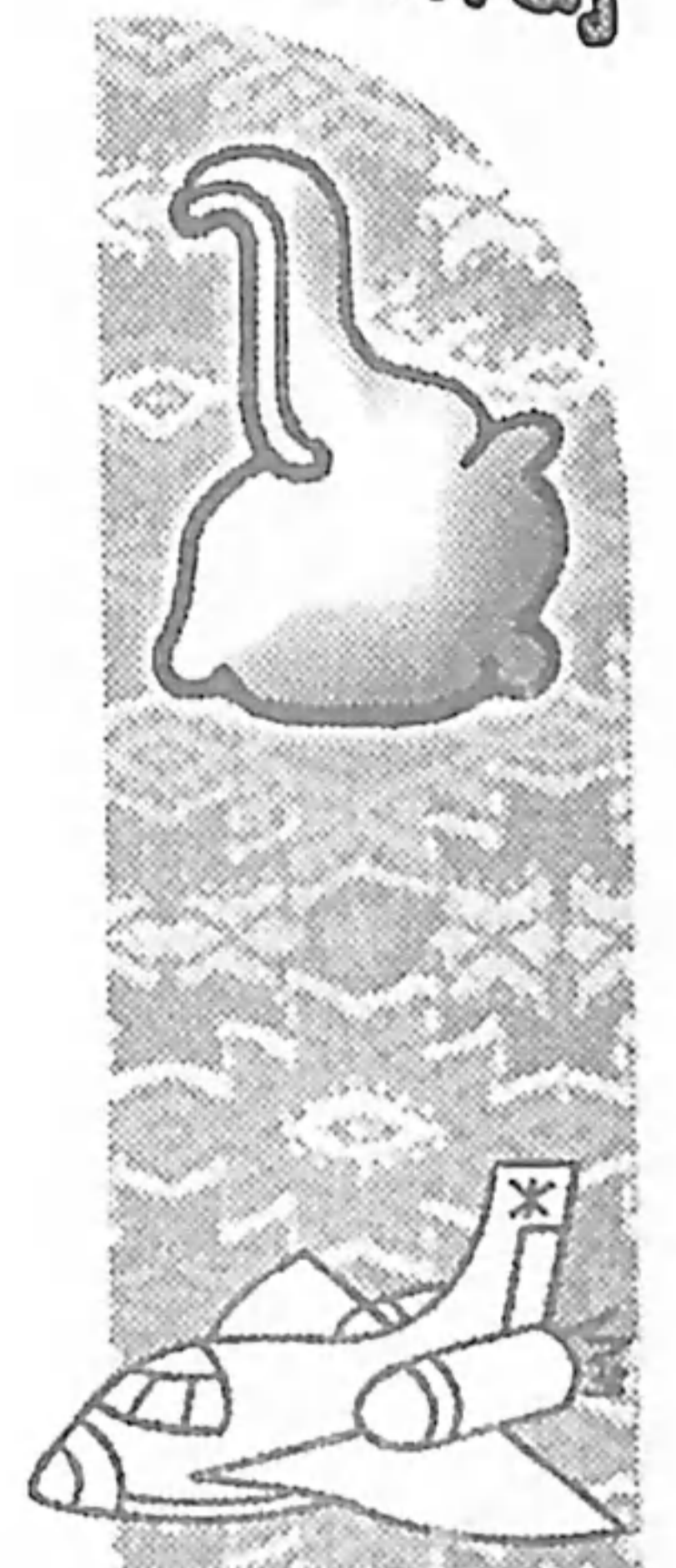

Xwan: Tab'ana' utzil  
tawoyoj jub'a' ri ate'

Ixkotz'i'j: üt k'a tawoyob'ej na  
jub'a'.

Xwan: Matyox chawe.

Ixkotz'i'j: majun nub'an



Xwan: Tab'ana' utzil yiq'ax  
jub'a' awik'in

Ixkotz'i'j: üt k'a kaq'ax

Xwan: Matyox chawe.

Ixkotz'i'j: majun nub'an.

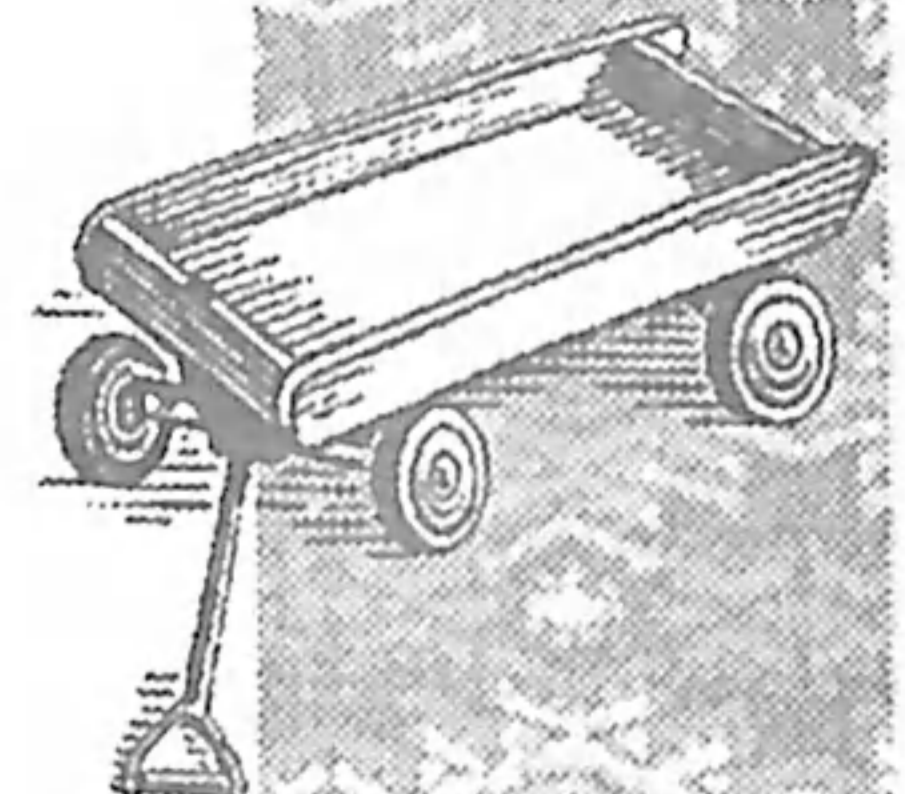
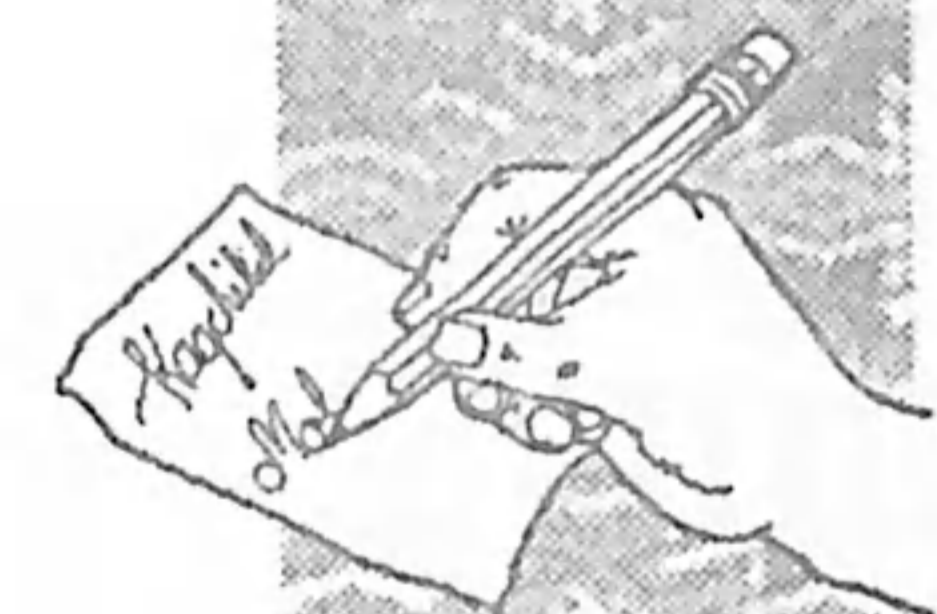

Tikirel yeb'e' rik'in ri tijonel, pa rochoch jun tijoxel richin nkik'utuj utzil.

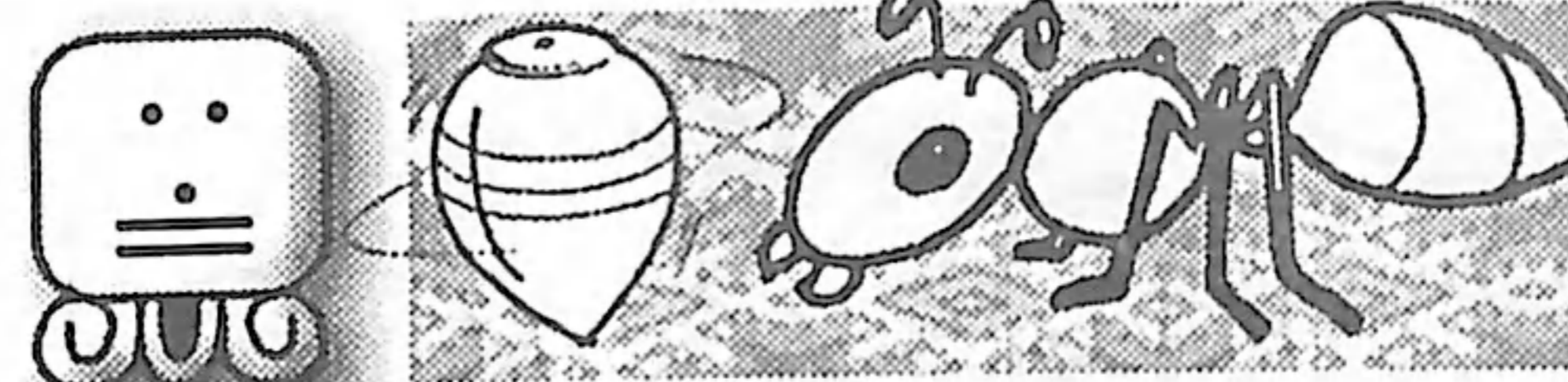
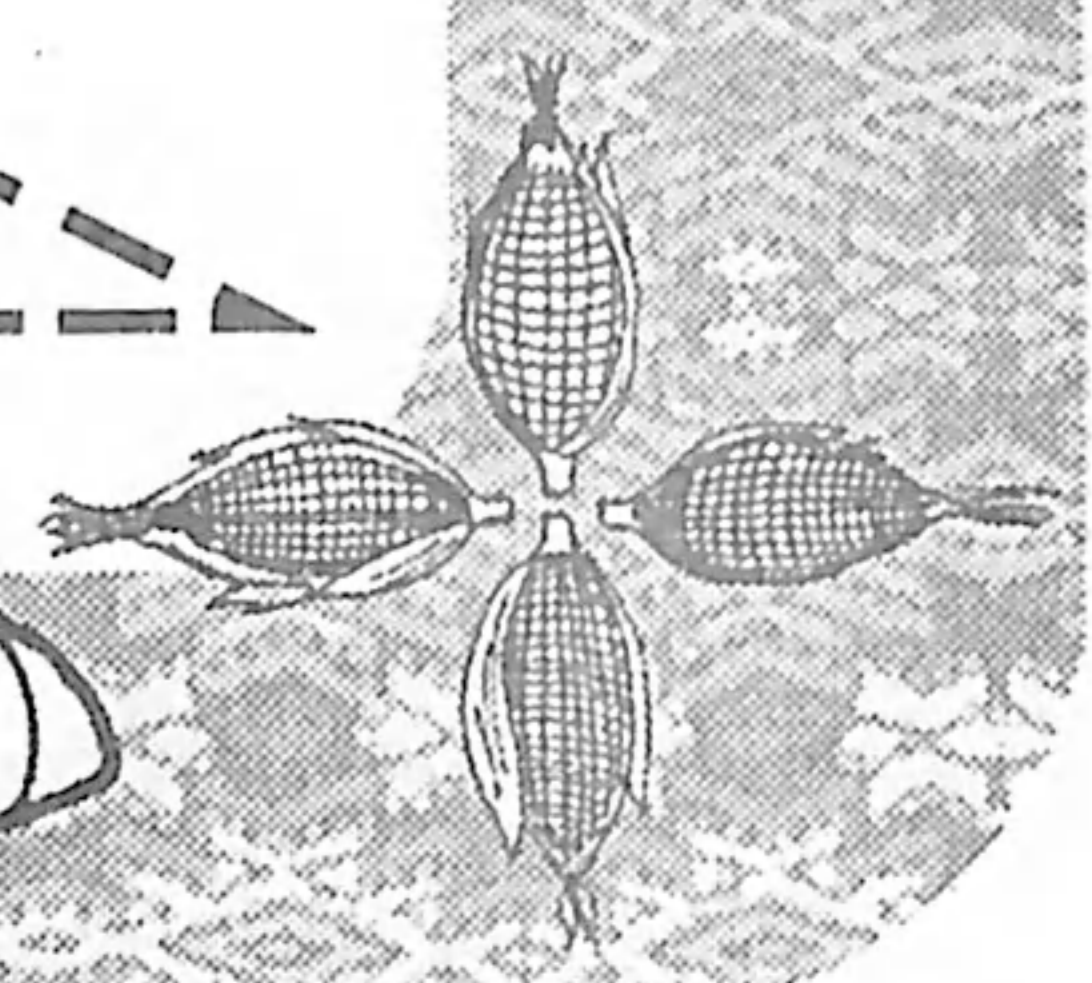



# Tqab'ana' re jun samaj re'

Keqatunu' rik'in jun juch' ri achib'äl rik'in ri achib'äl.

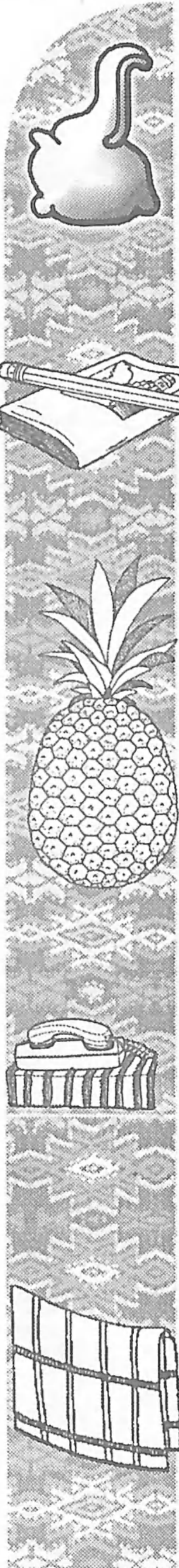

Nsamäj ri achin



Yetz'ib'an ri tijoxela'



Nq'ejelon ri tijoxel

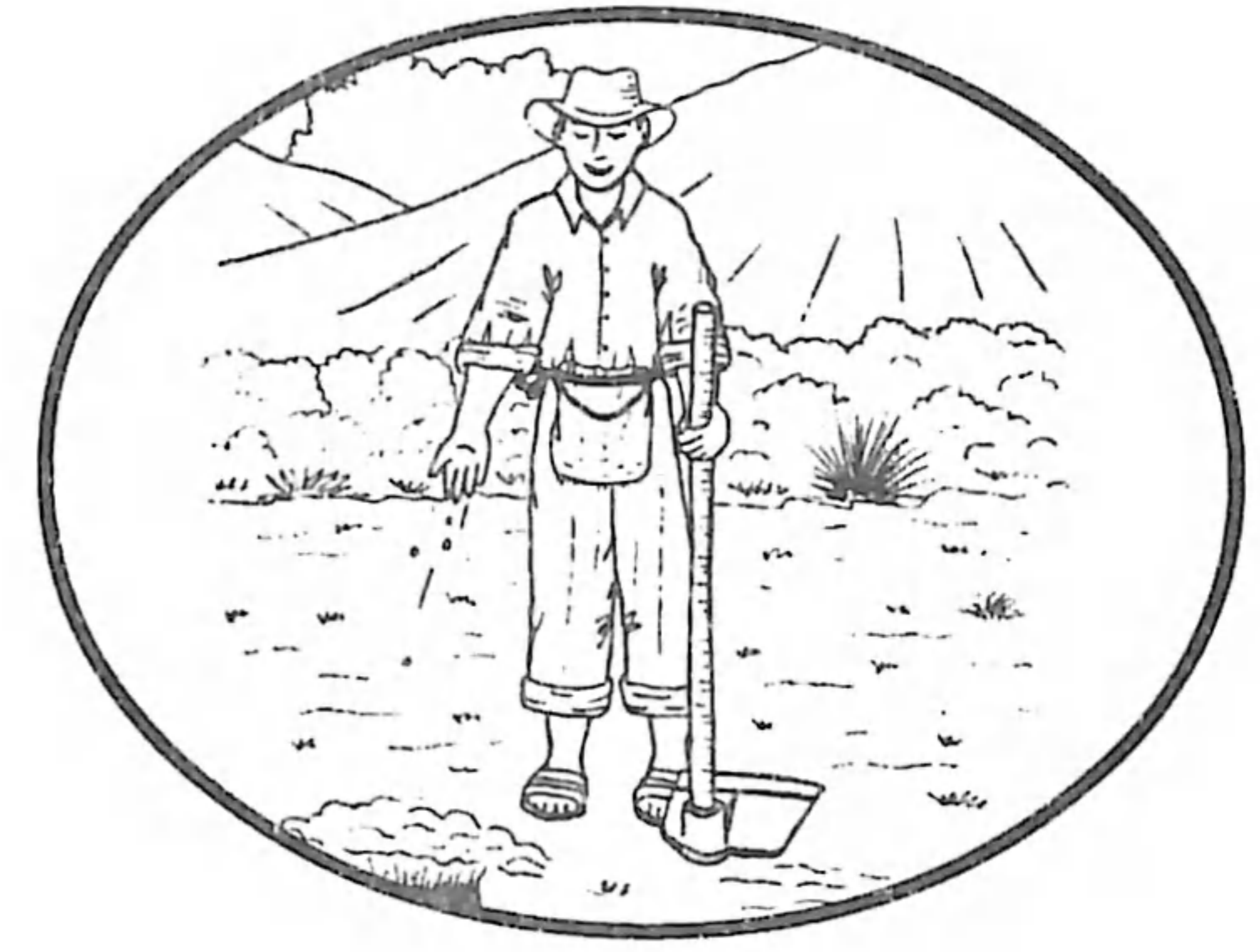

Nb'ixan ri tijonel



Ri tijoxela' nkitun ri achib'äl rik'in ri kib'i'.

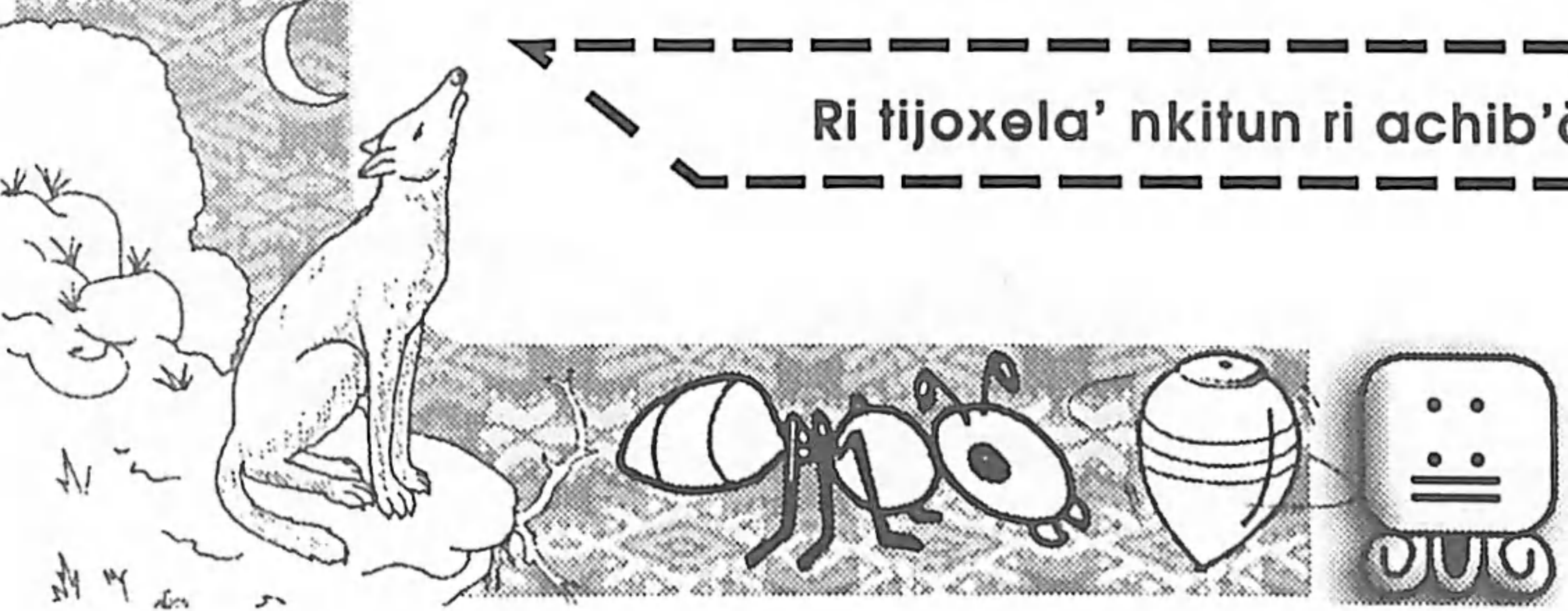

Kotzizon pa ruwi' re jun achib'äl re'

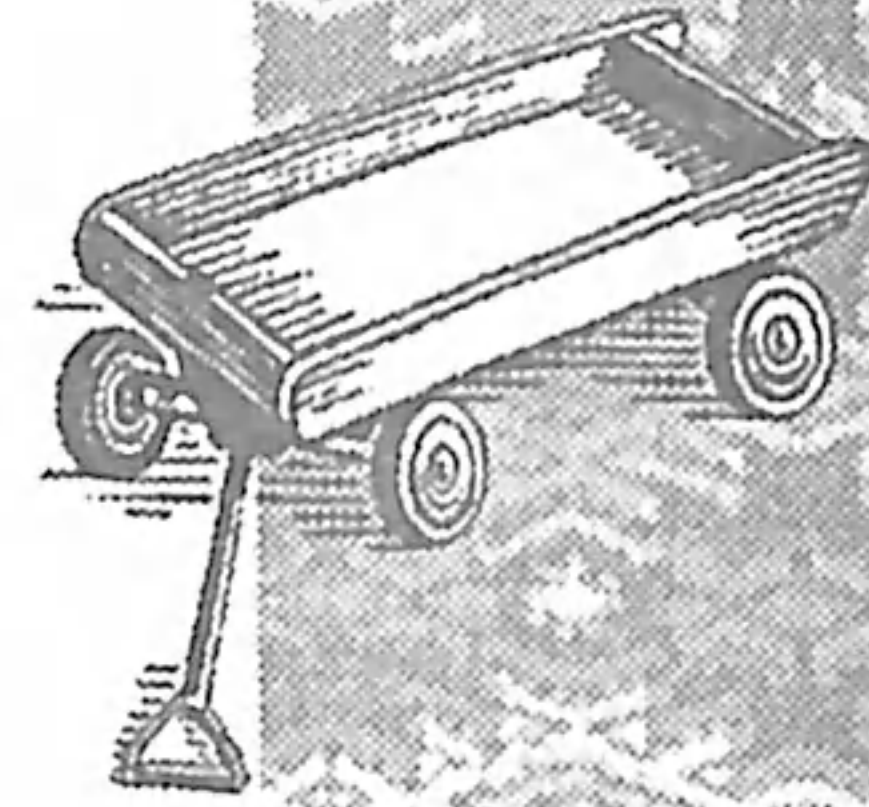
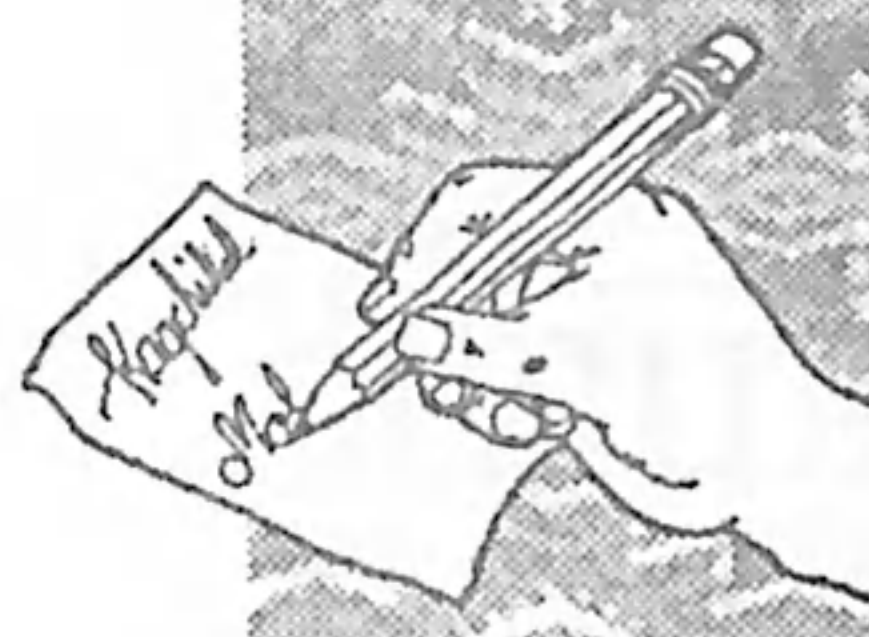
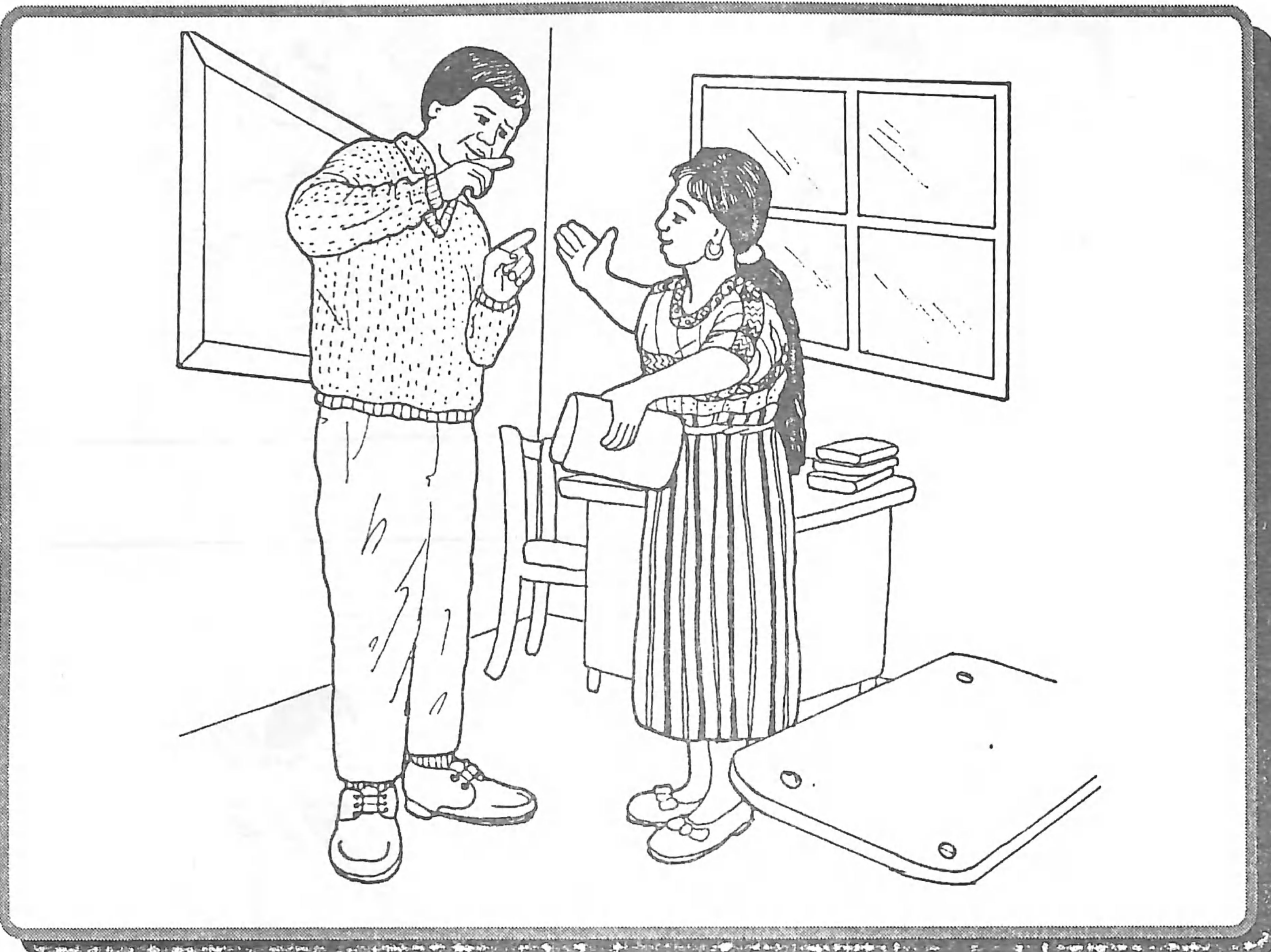

A large rectangular area with horizontal lines for writing. In the bottom right corner of this area, there is a small illustration of a pencil.

Ri tijoxela' nkitz'ib'aj pa ruwi' ri kajtz'uk ronojel ri nkitz'ët chupam ri achib'äl.



# Tojtob'enik



Blank writing area with two horizontal lines.

Blank writing area with two horizontal lines.



Blank writing area with two horizontal lines.

Blank writing area with two horizontal lines.

Kojtzijon pa kaka': Tqaqaja' jun sik'iwuj.  
Tqak'utuj utzil richin yojq'ax

Ri tijoxela' nkitz'ib'aj ka'i' taq b'ab' pa ruwi' ri nkitz'ët chupam ri achib'äl.  
Chuqa' yetzijon pa ruwi' ri nk'utux chi ke.

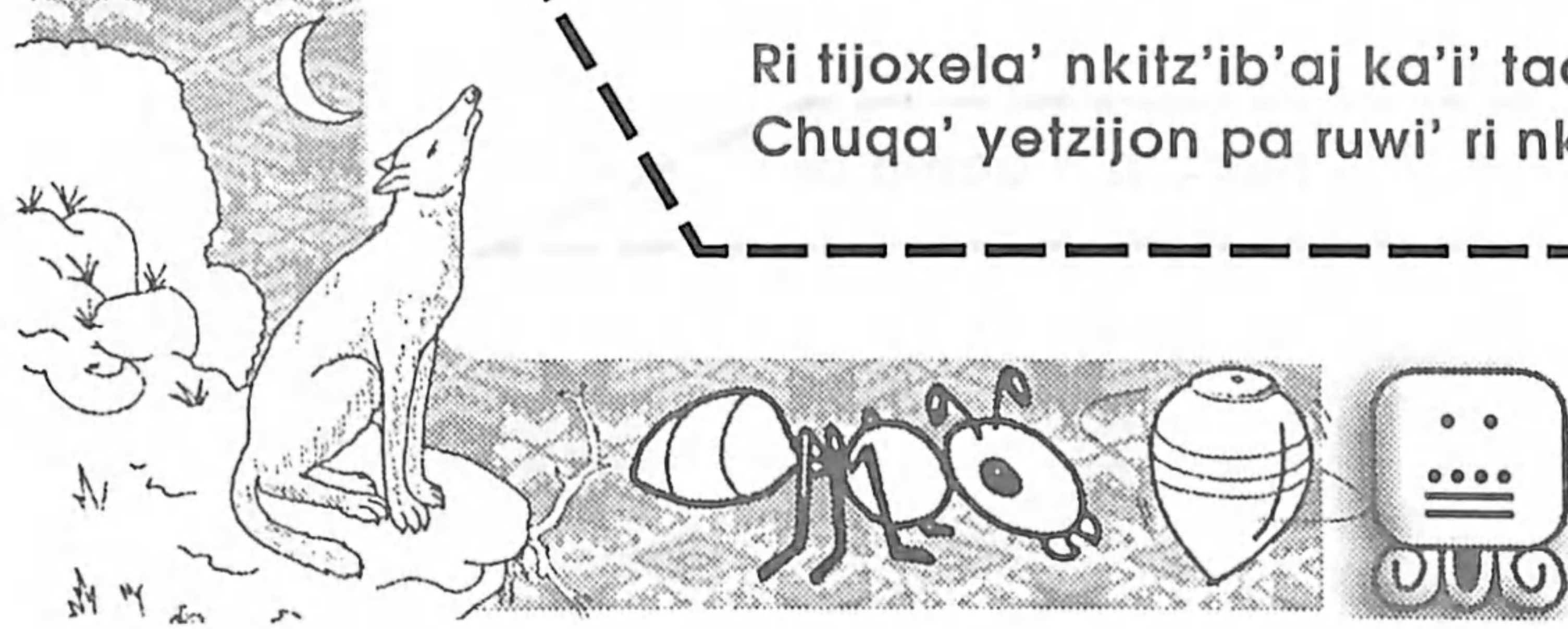

# RO' TANAJ

## Ri tzyaqb'äl



### Ri etamanik nuq'i' ri tijoxel:

Rub'i' chuqa' ruwäch ri jalajöj kib'onil ri tzyaqb'äl.  
Nretamaj ri jalajöj kipimil ri tzyaqb'äl, pim, xax.  
Ntzijon pa ruwi' ri tzyaqb'äl.

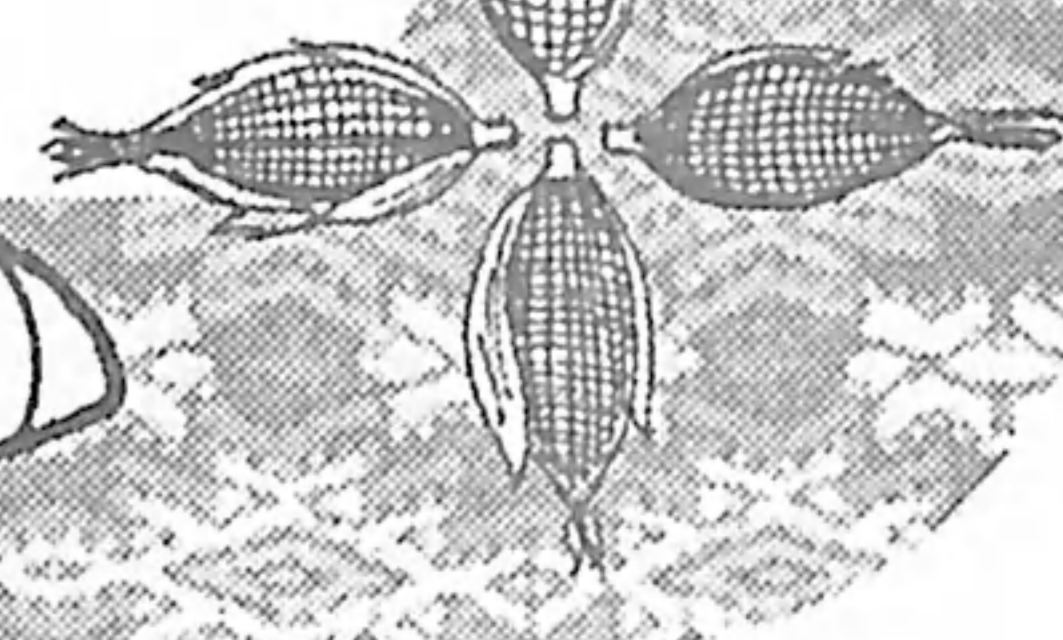
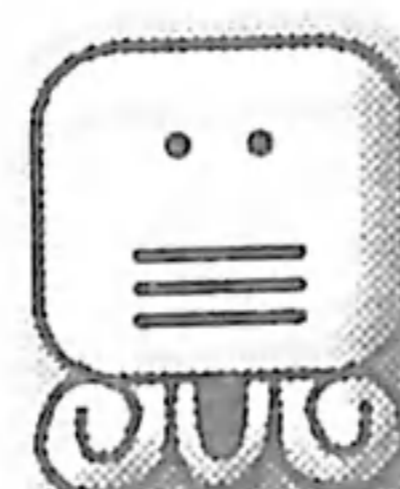
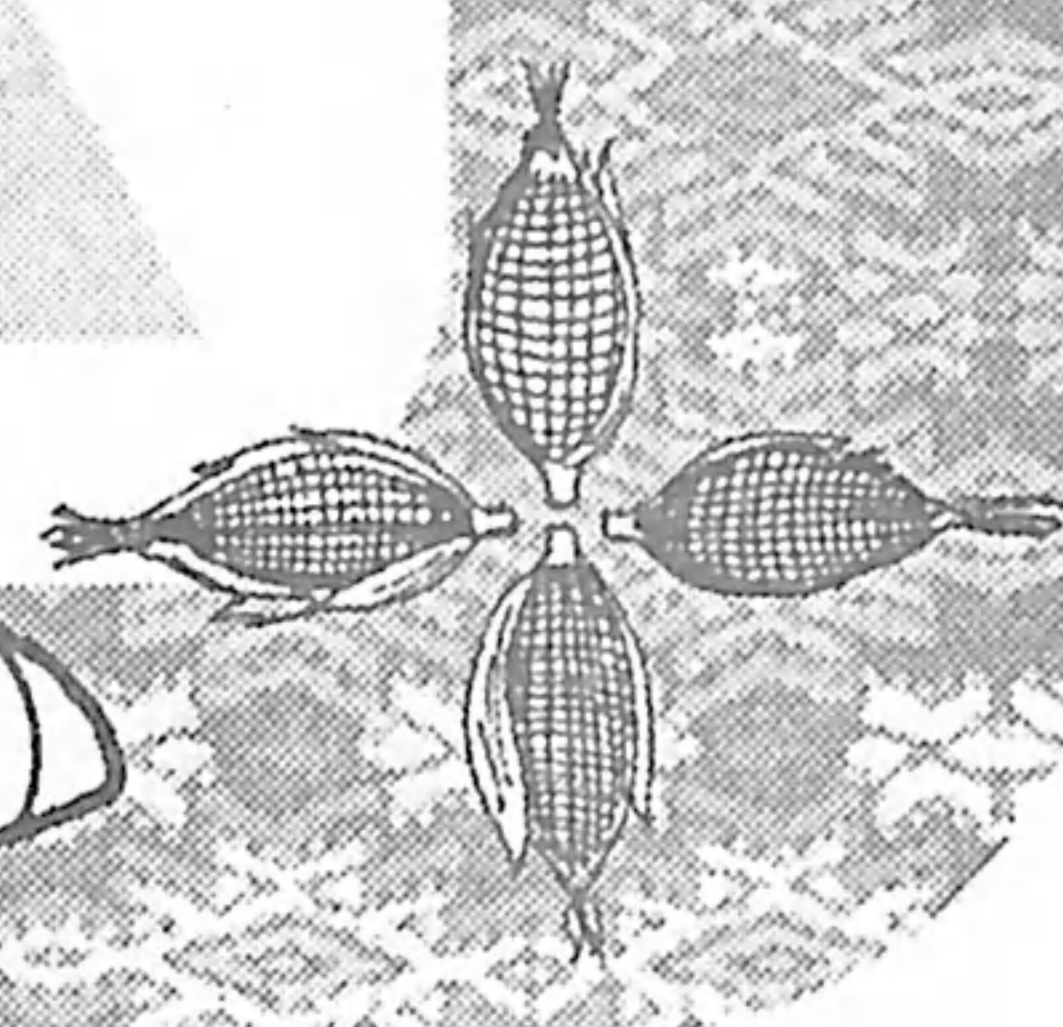
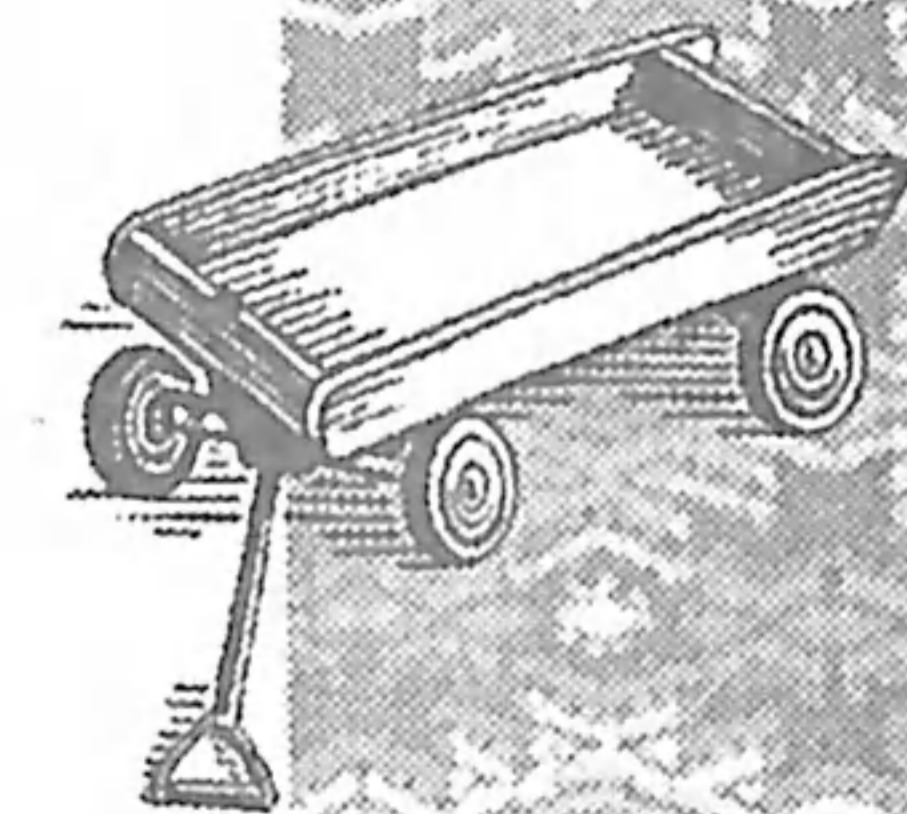
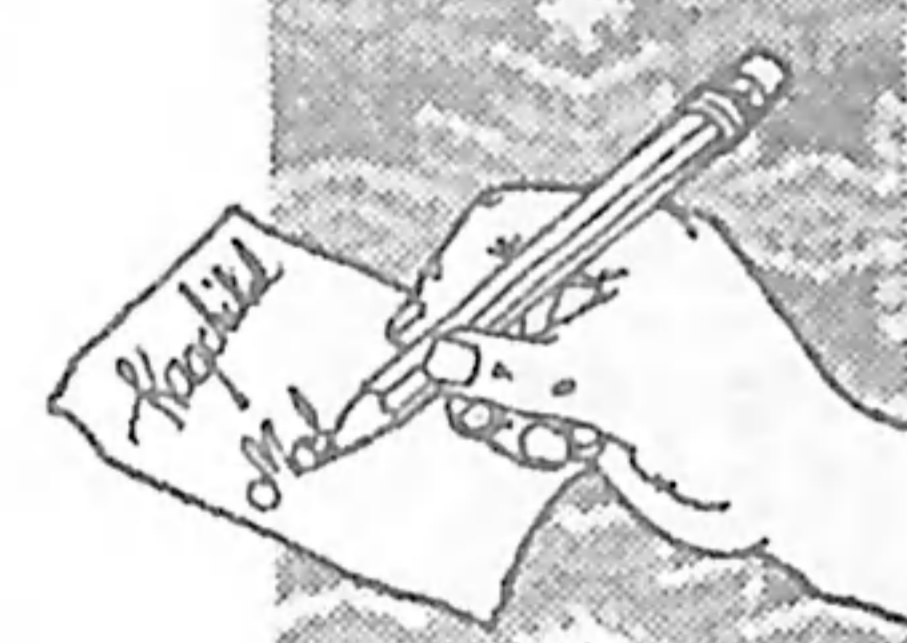



Tqab'onij rutzyaq ri ti ixtän, chuqa' ri ti ala' rik'in jalajöj ruwäch b'onil

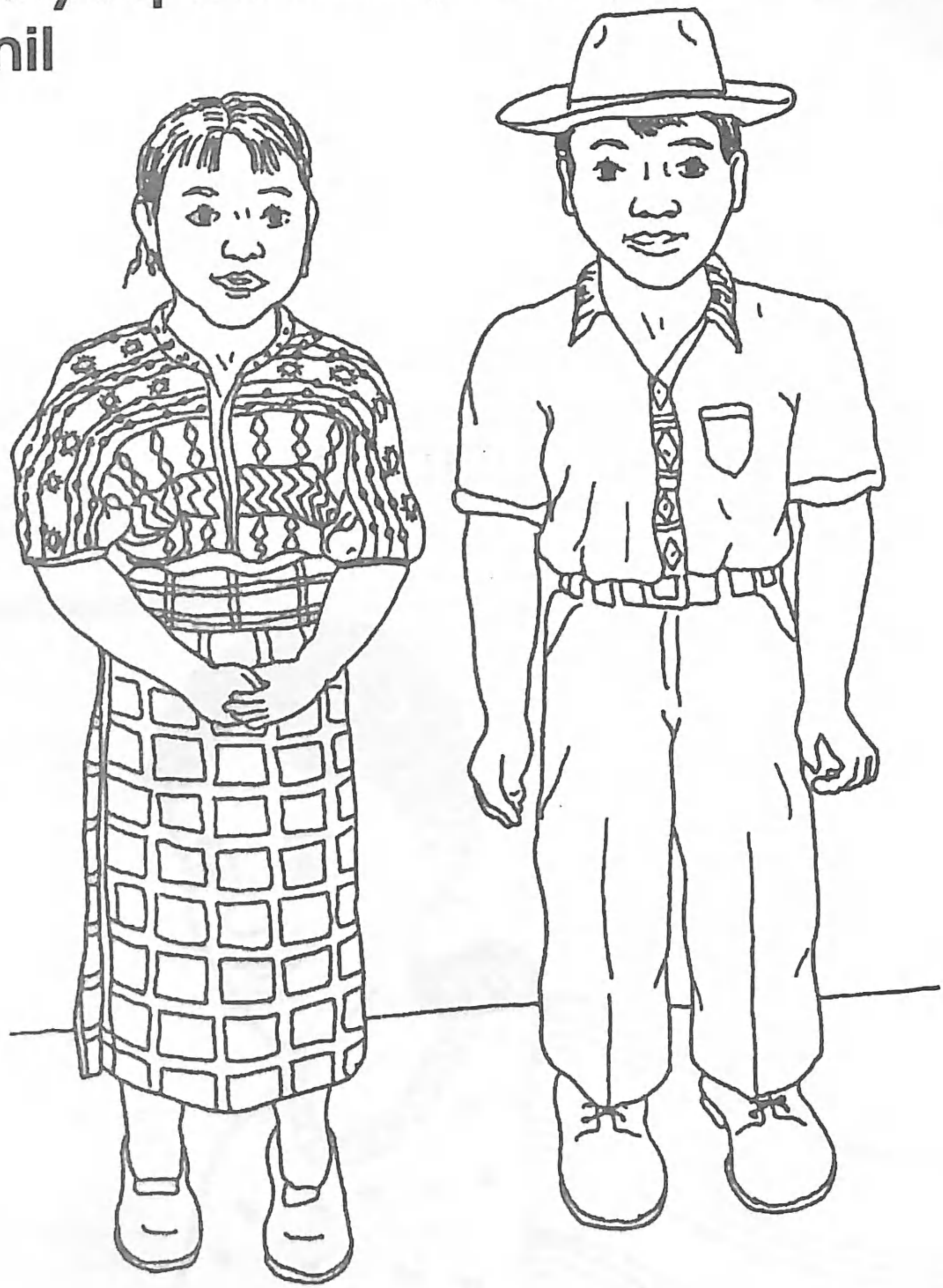

Tqab'onij ri taq kajtz'uk rik'in ri b'onil nk'utux

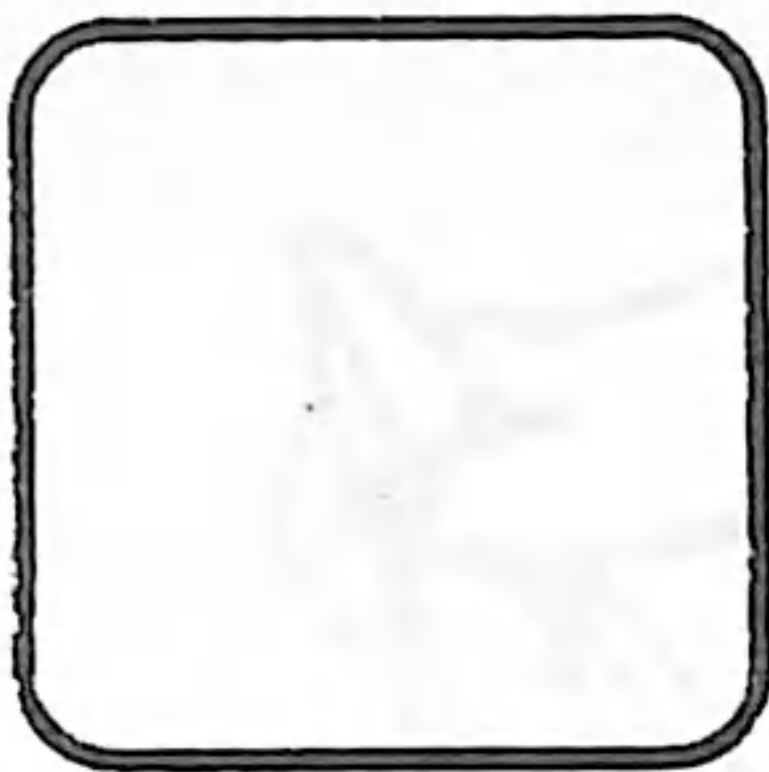

Käq



Säq



K'aqo'j

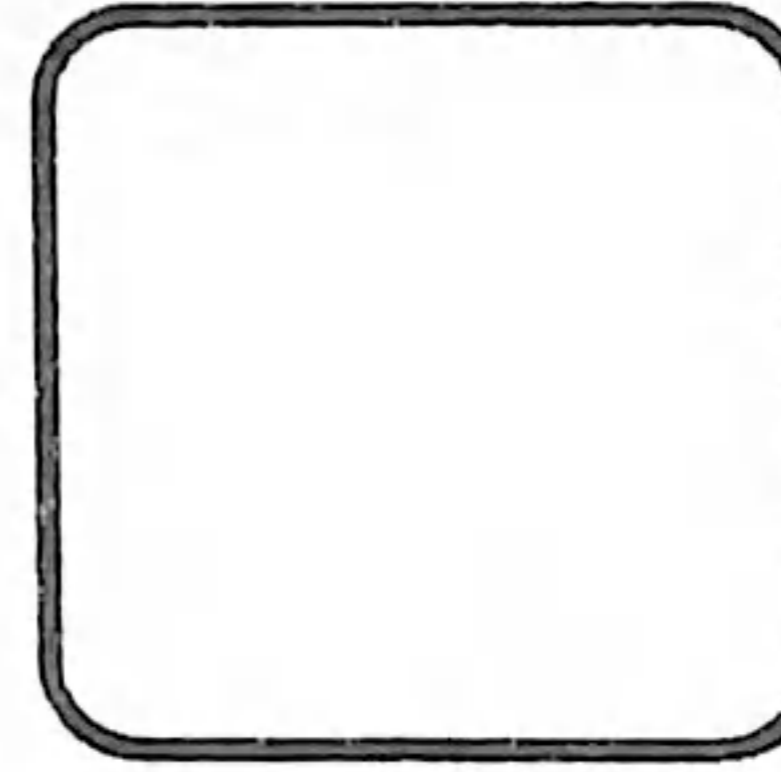

xar



räx



saqsöj

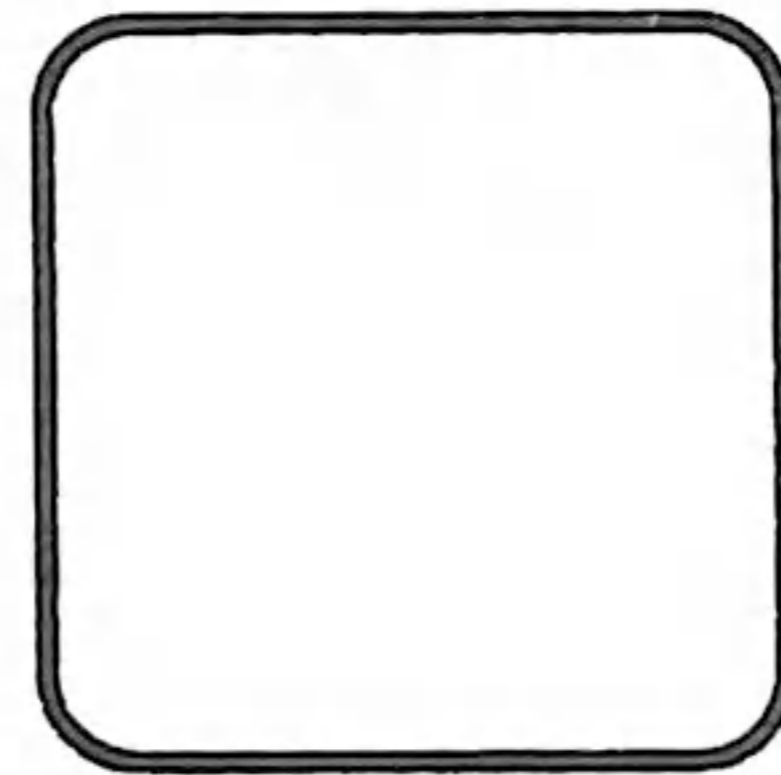

q'eq

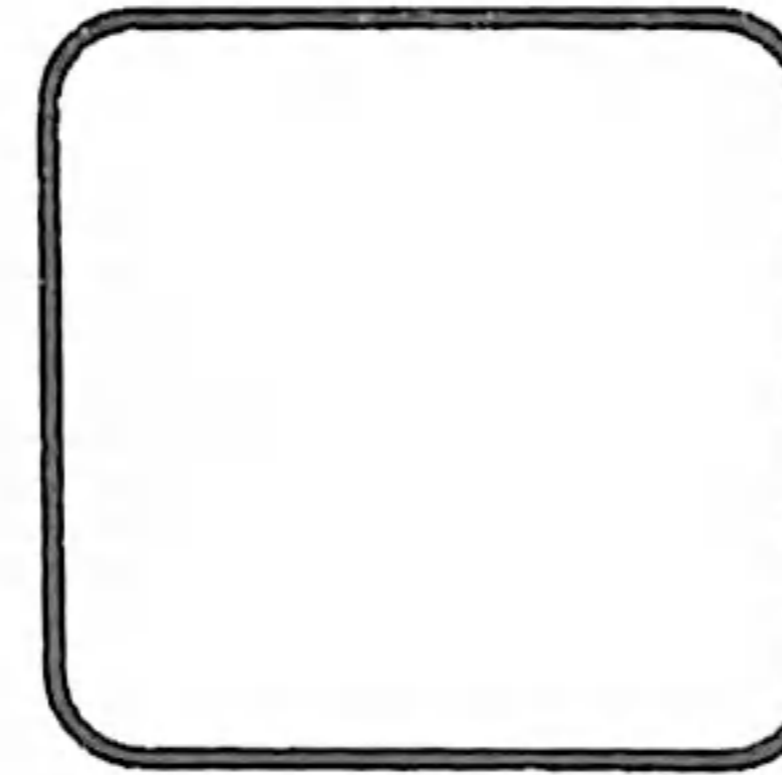

q'anq'öj

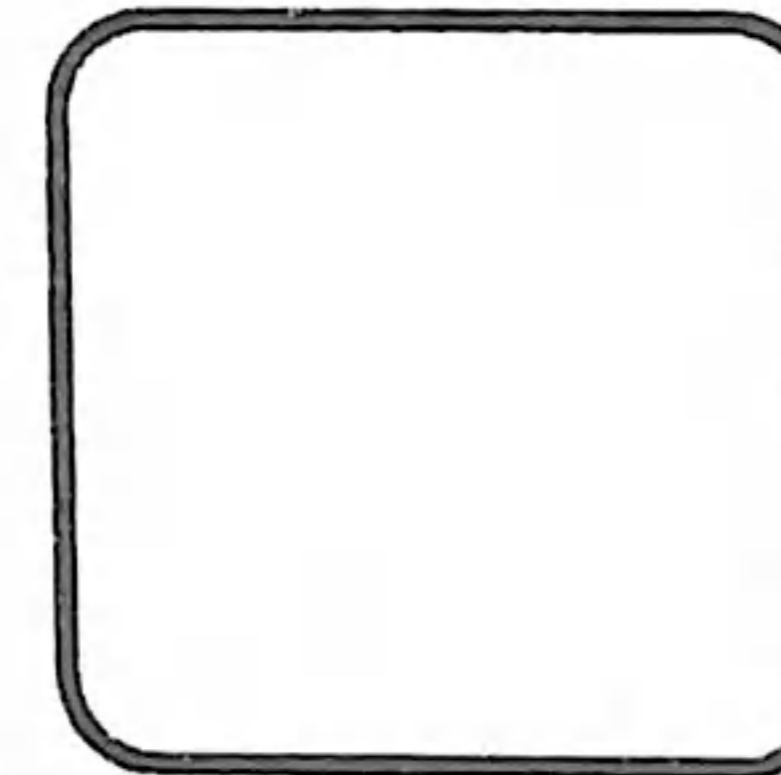

raxröj

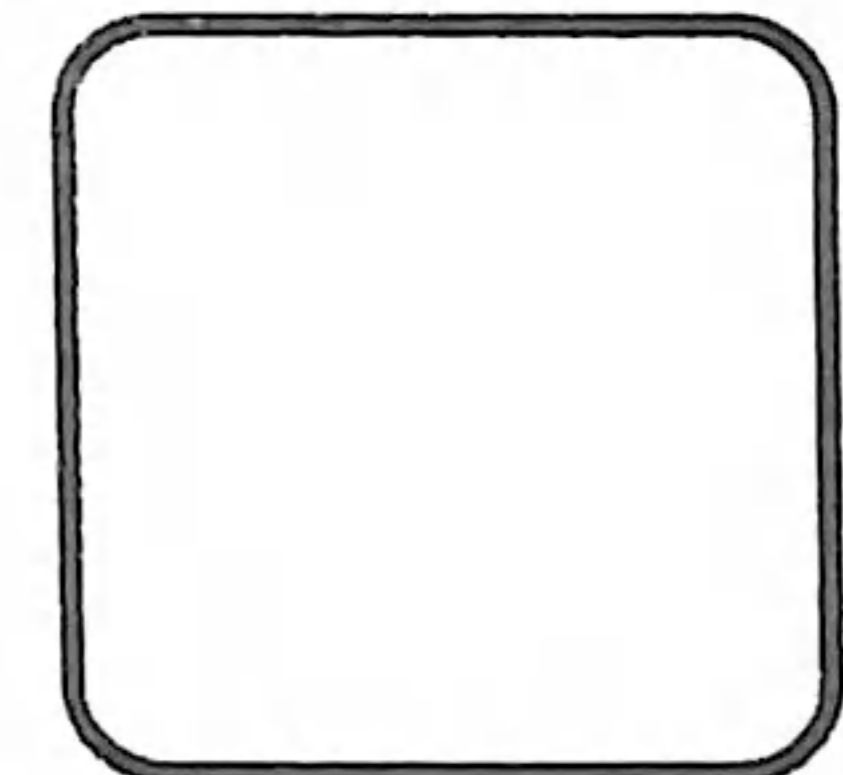

Saqsöj

Ri tijonel k'o chi yeruto' ri tijoxela' richin nkib'onij ri achib'äl.



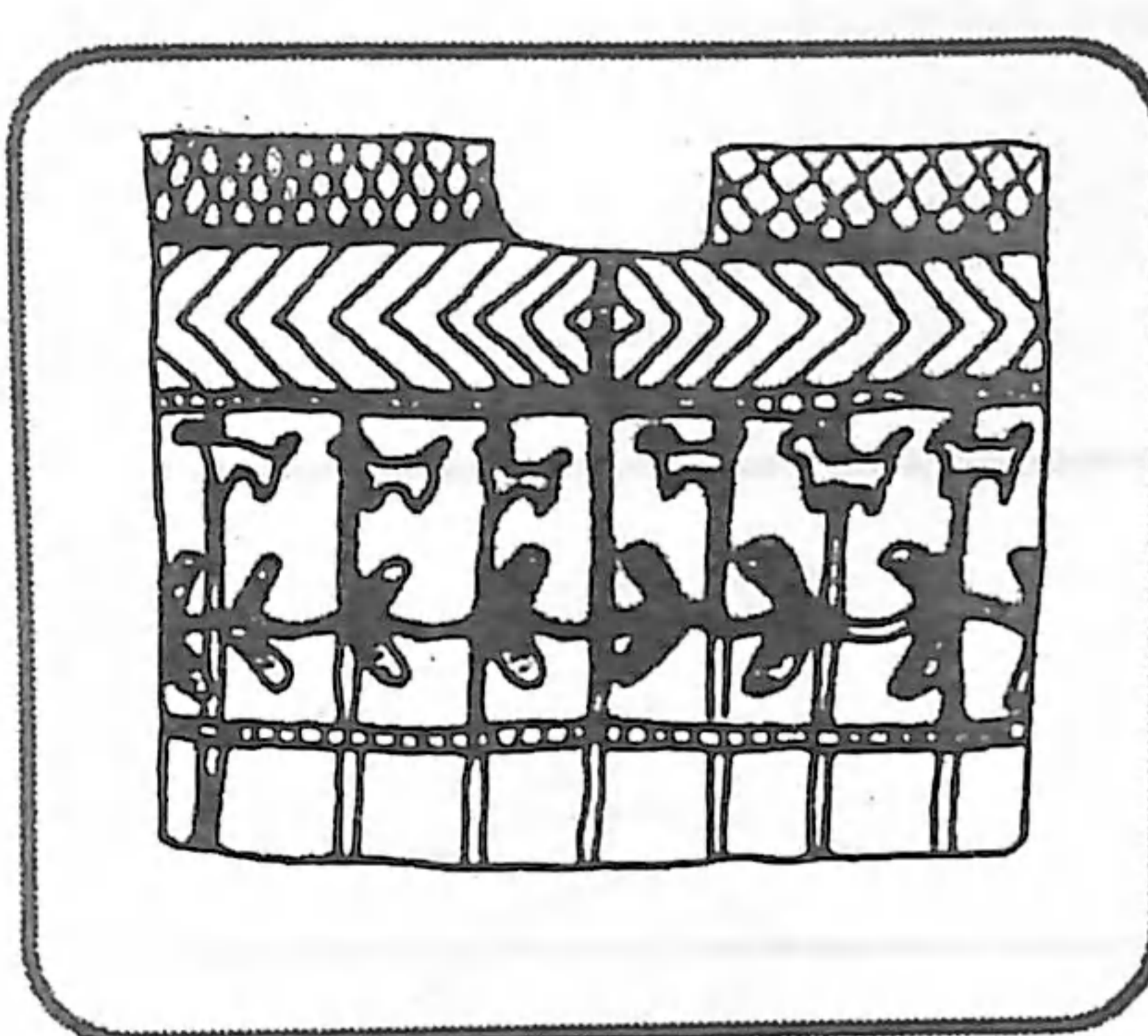

Po't

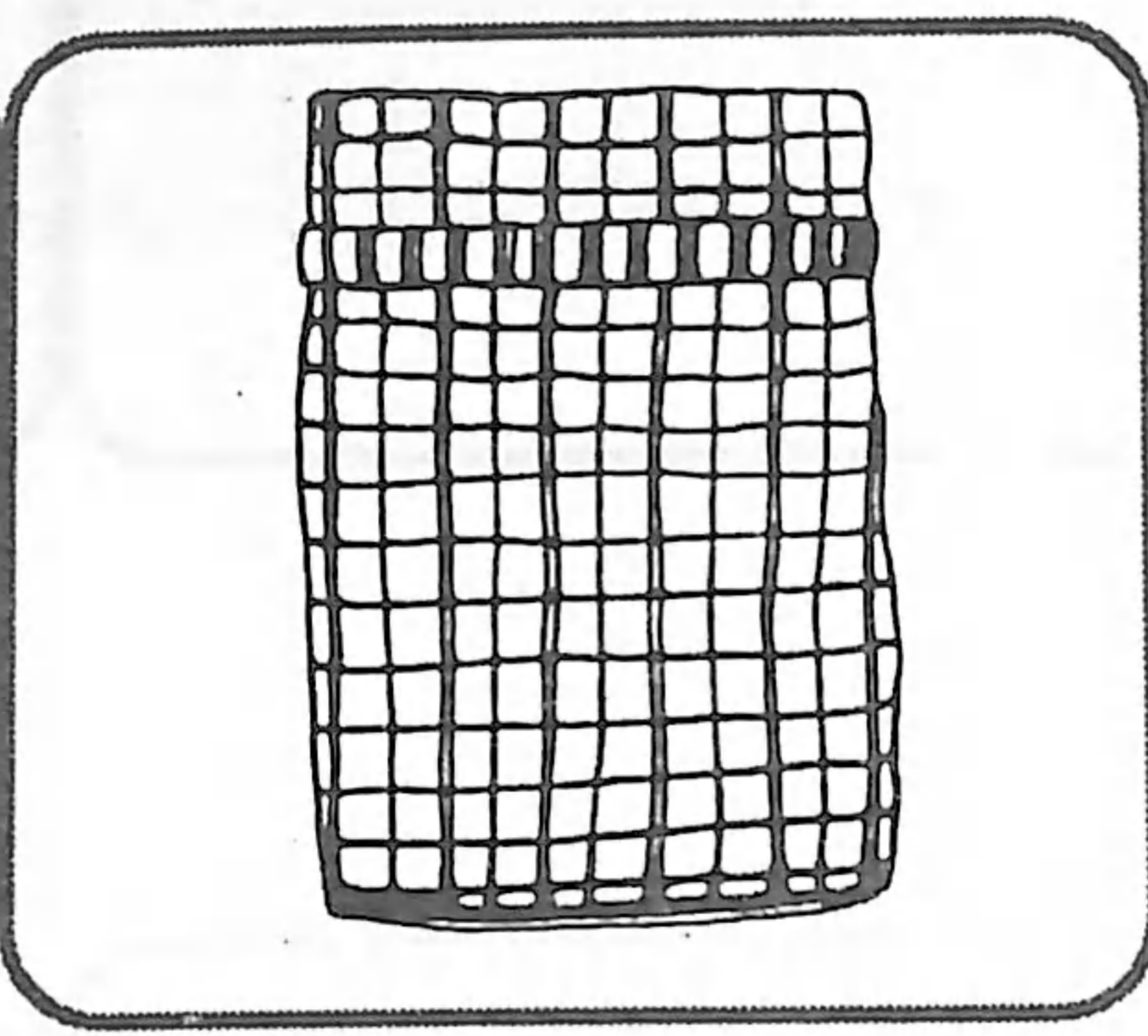

uq - uqaj



ejqab'al



Xoq'op

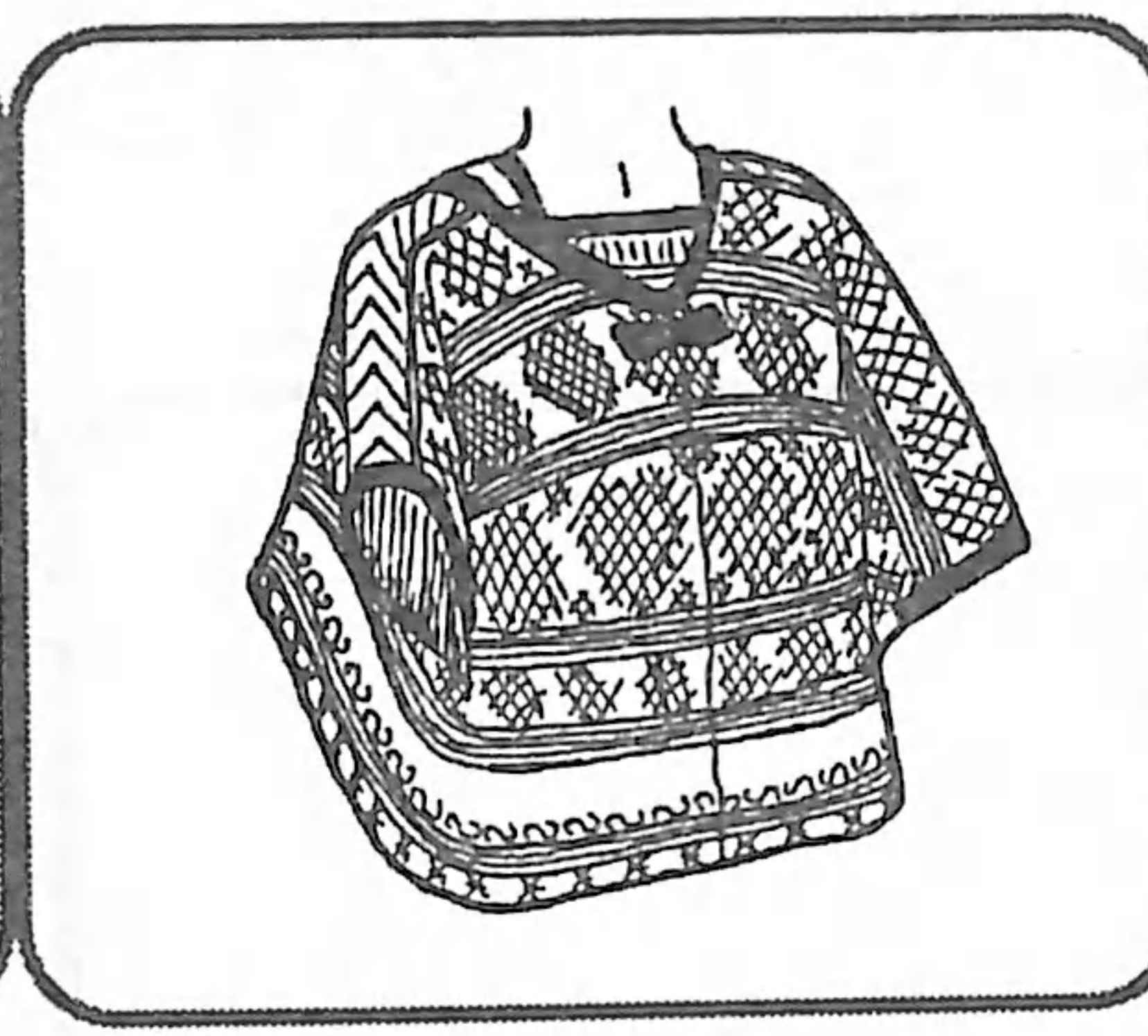

rij po't

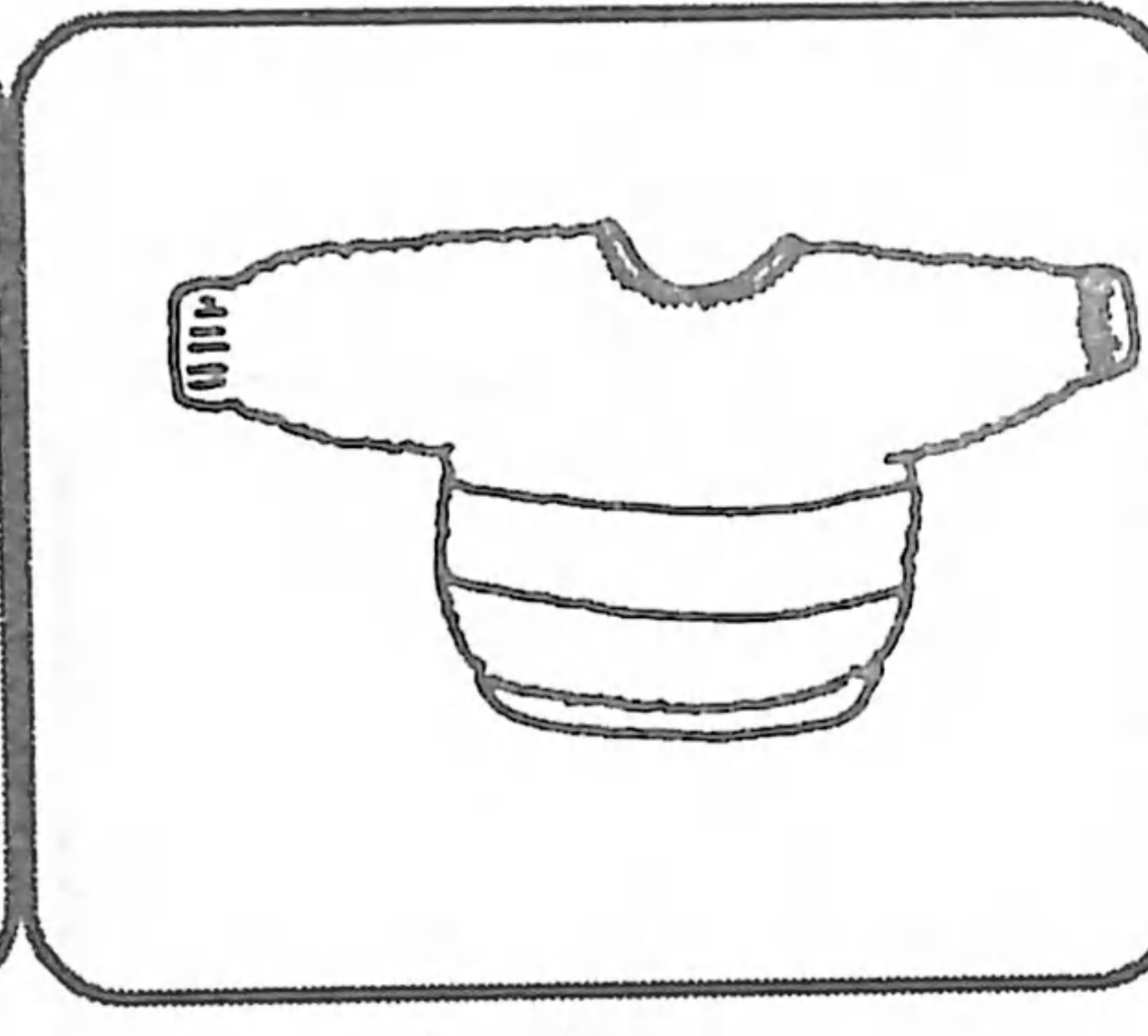

koton





# Qetamaj ka'i' oxi' taq tzij

## Rutzyab'äl ri achin

Ri Nwetamaj

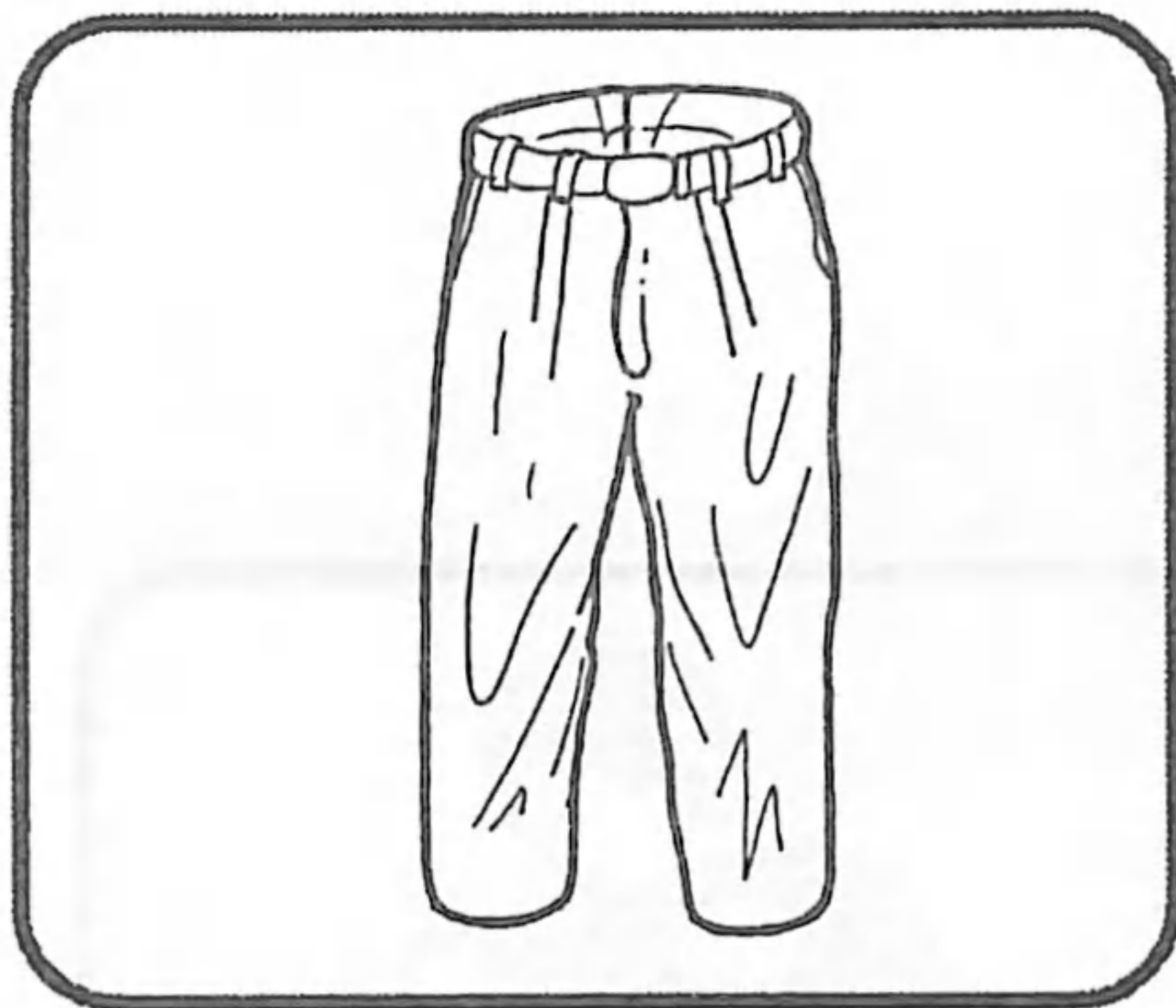

Wex

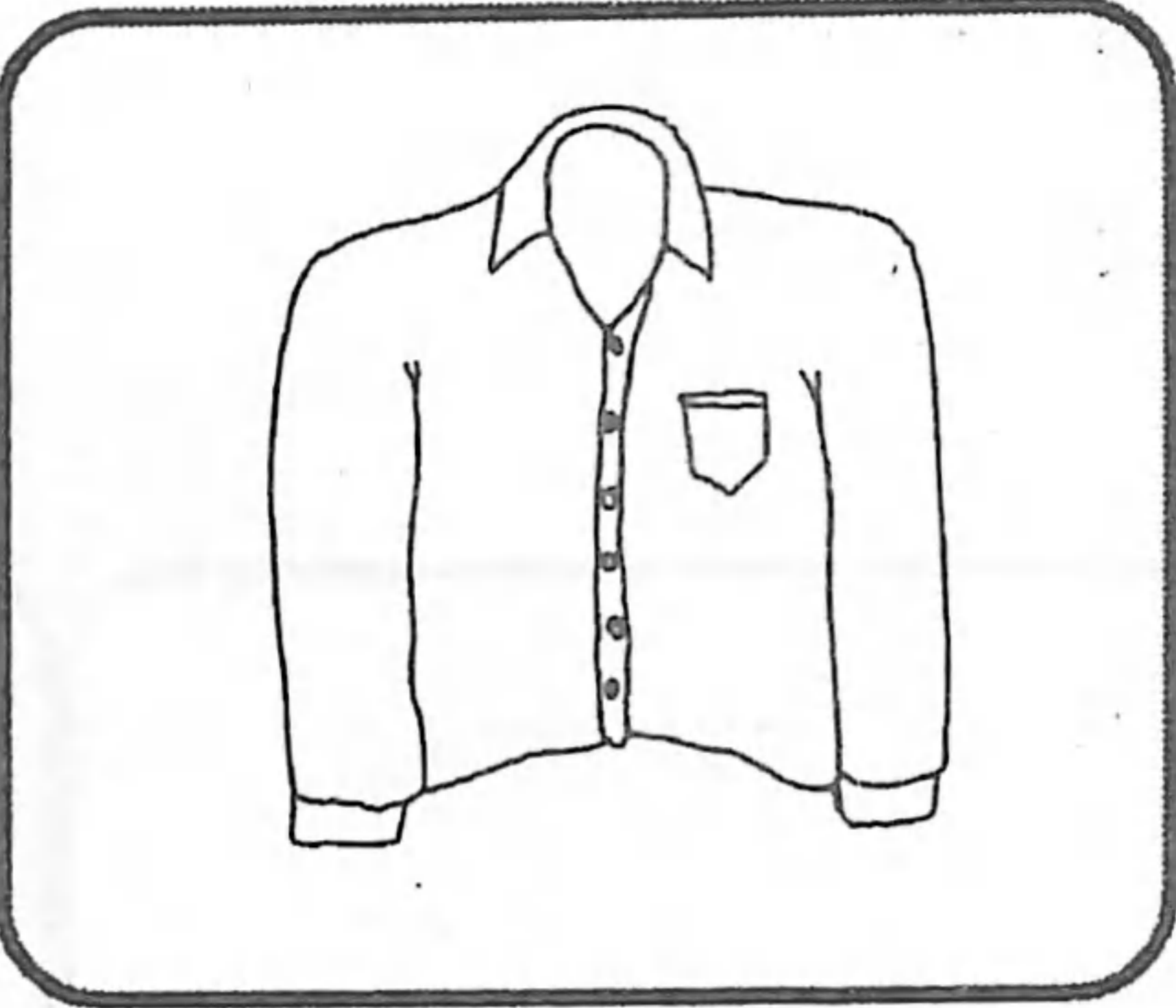

Kamixa'

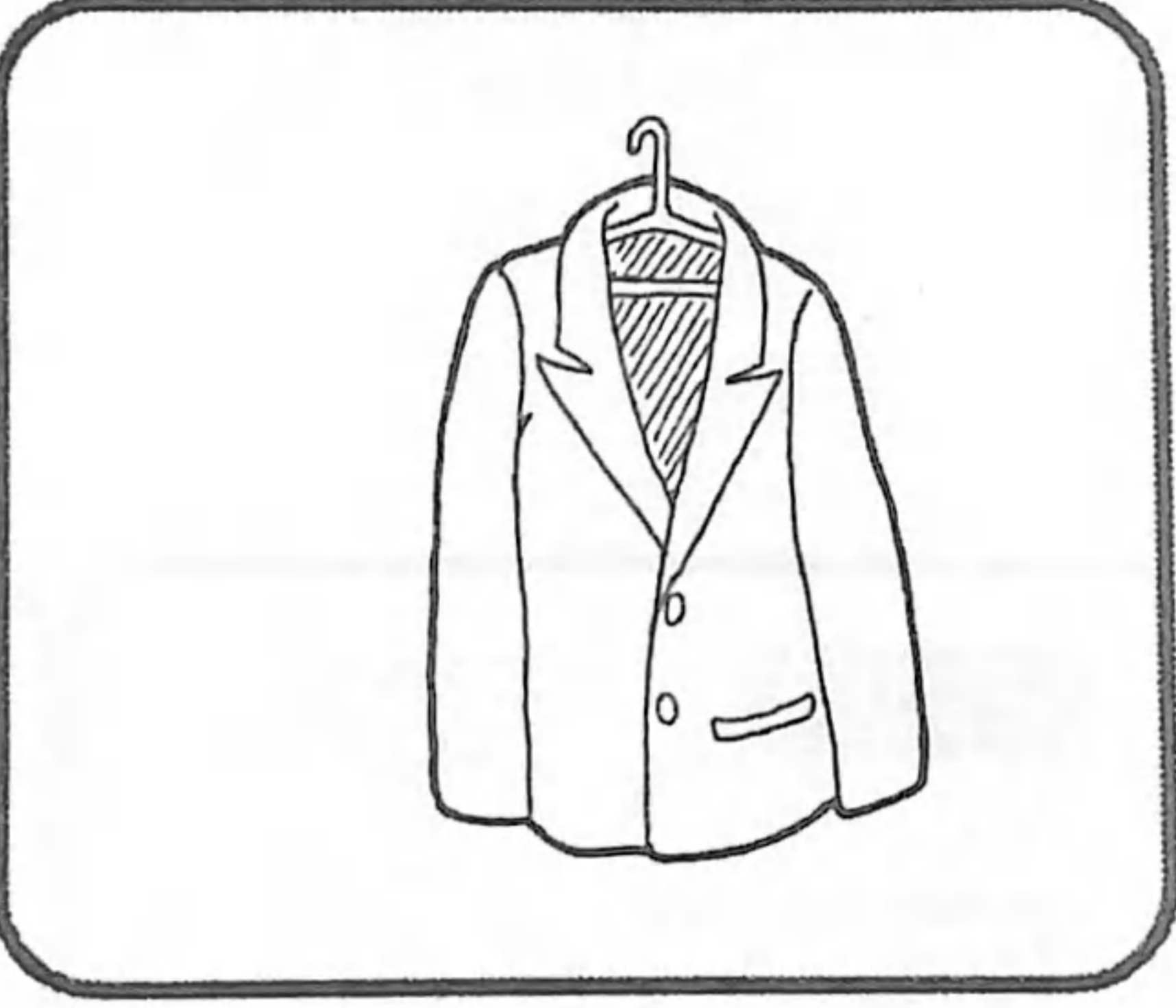

Koton

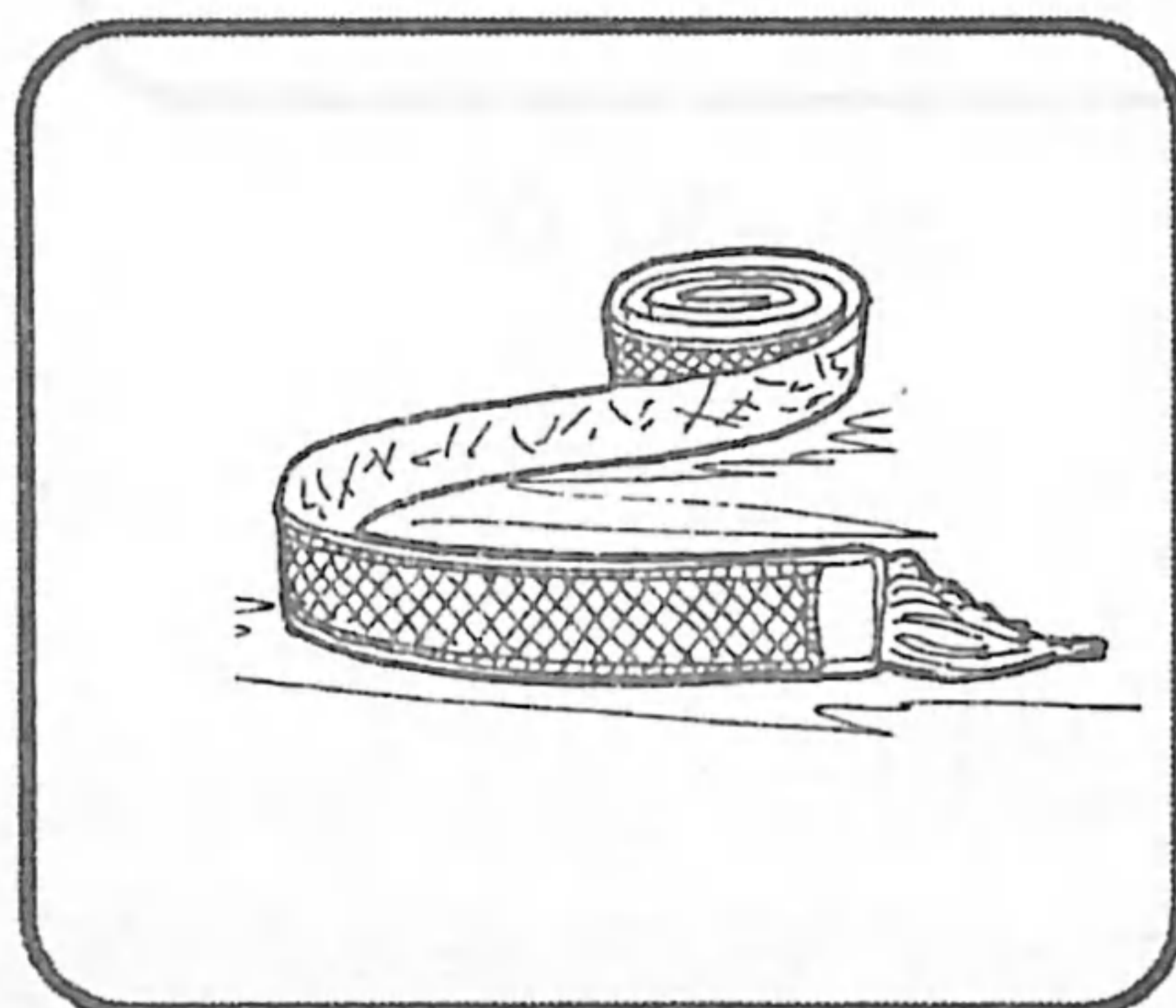

Pas - Ximb'äl

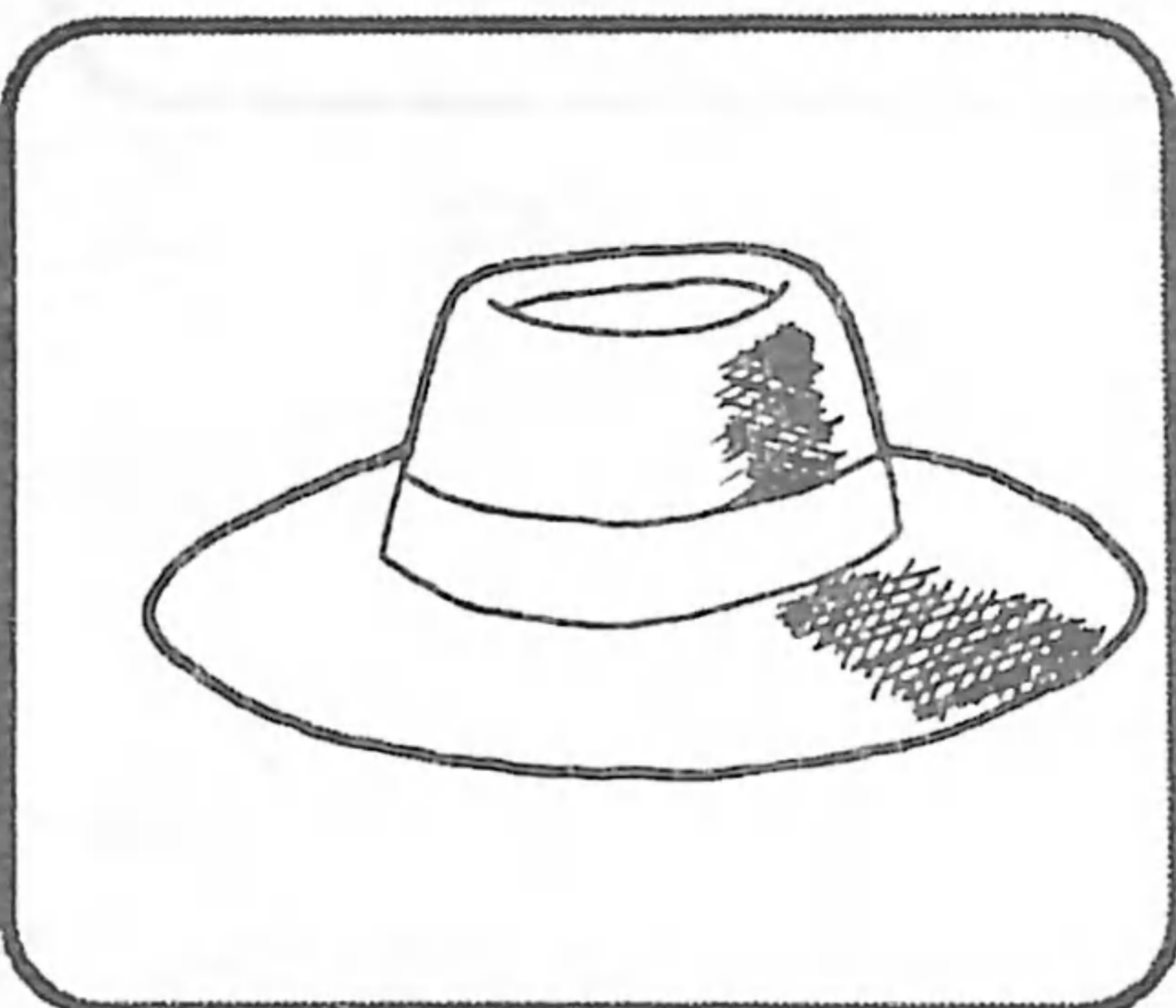

pawi'aj

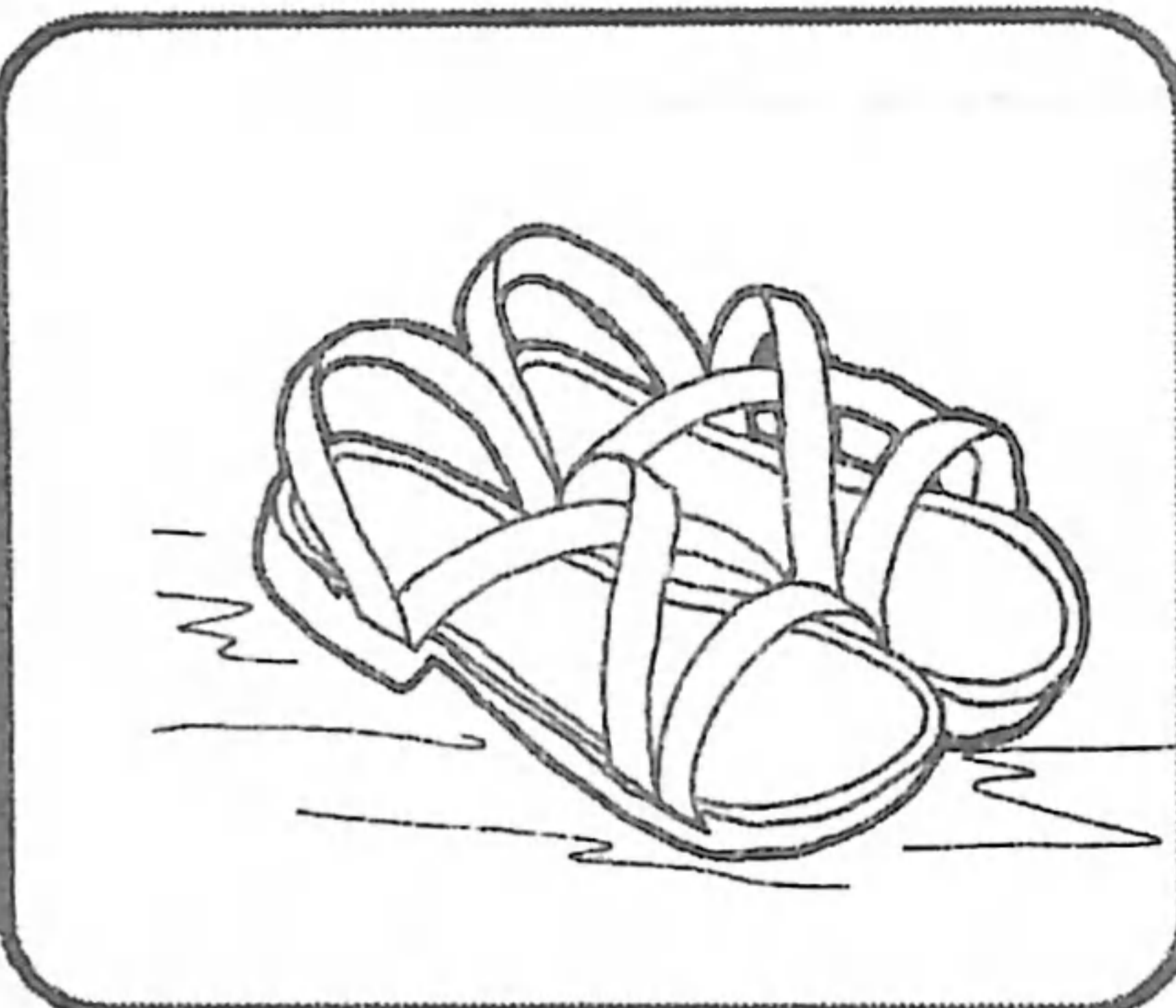

xajab'

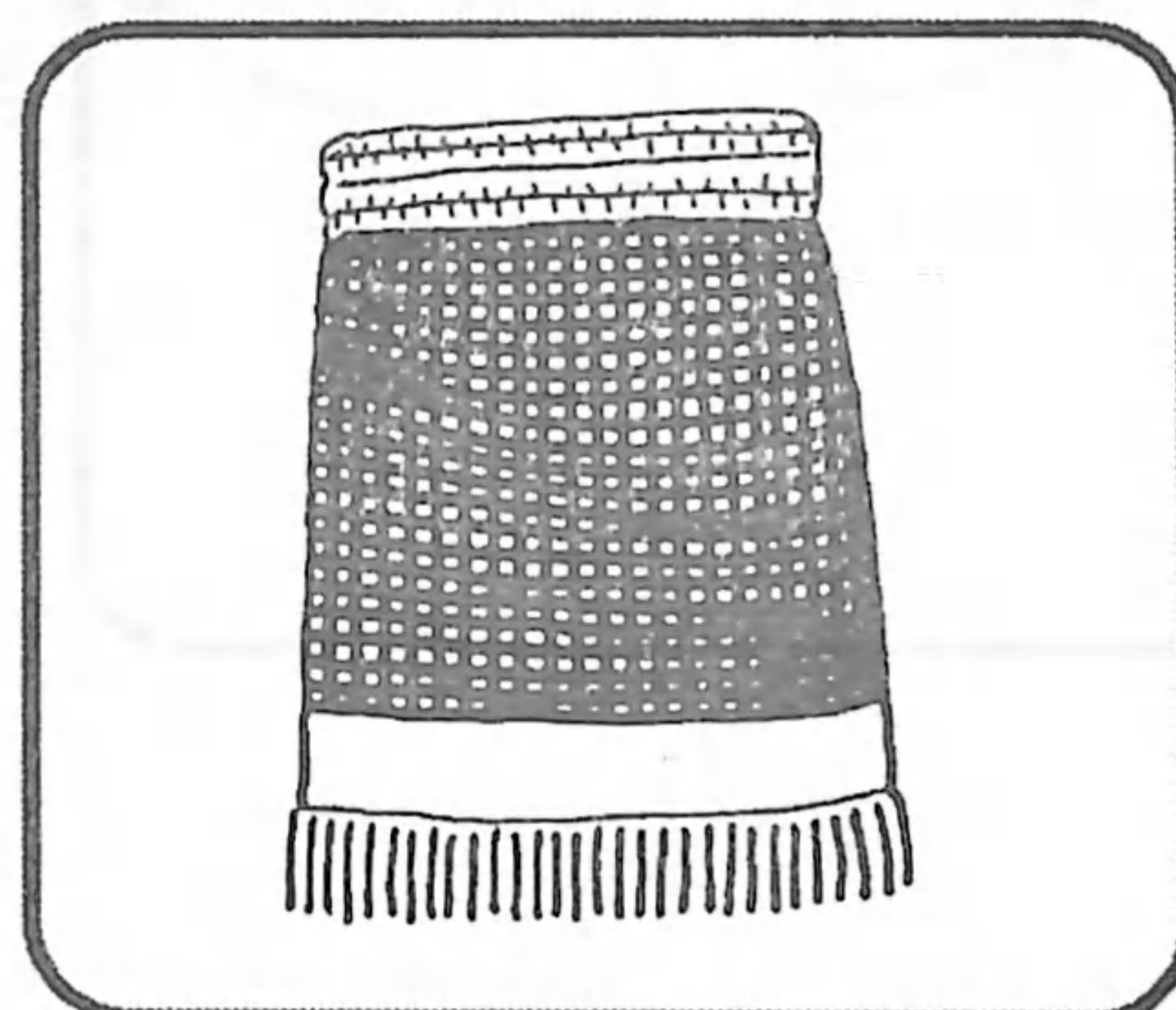

xerka

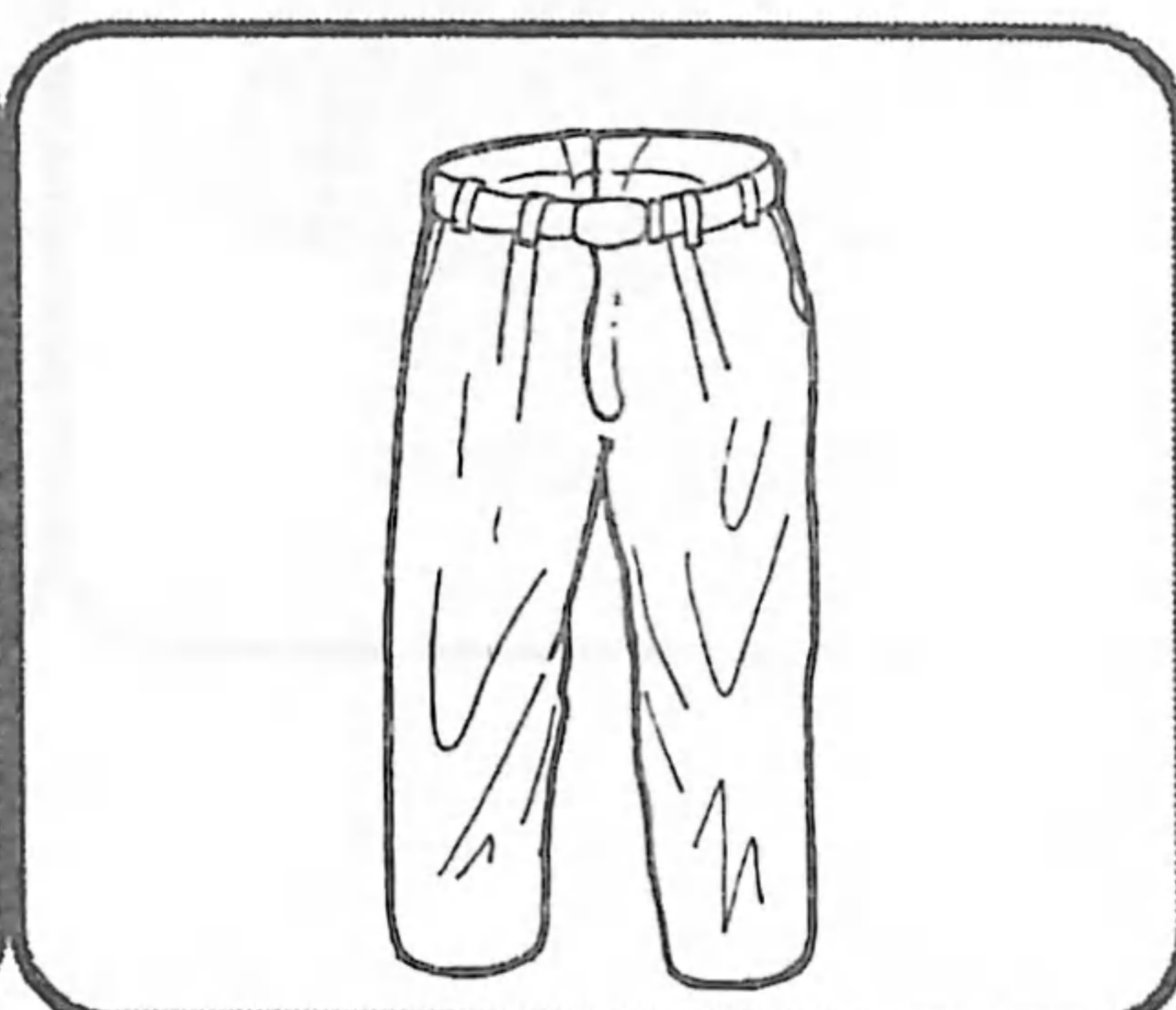

Wex

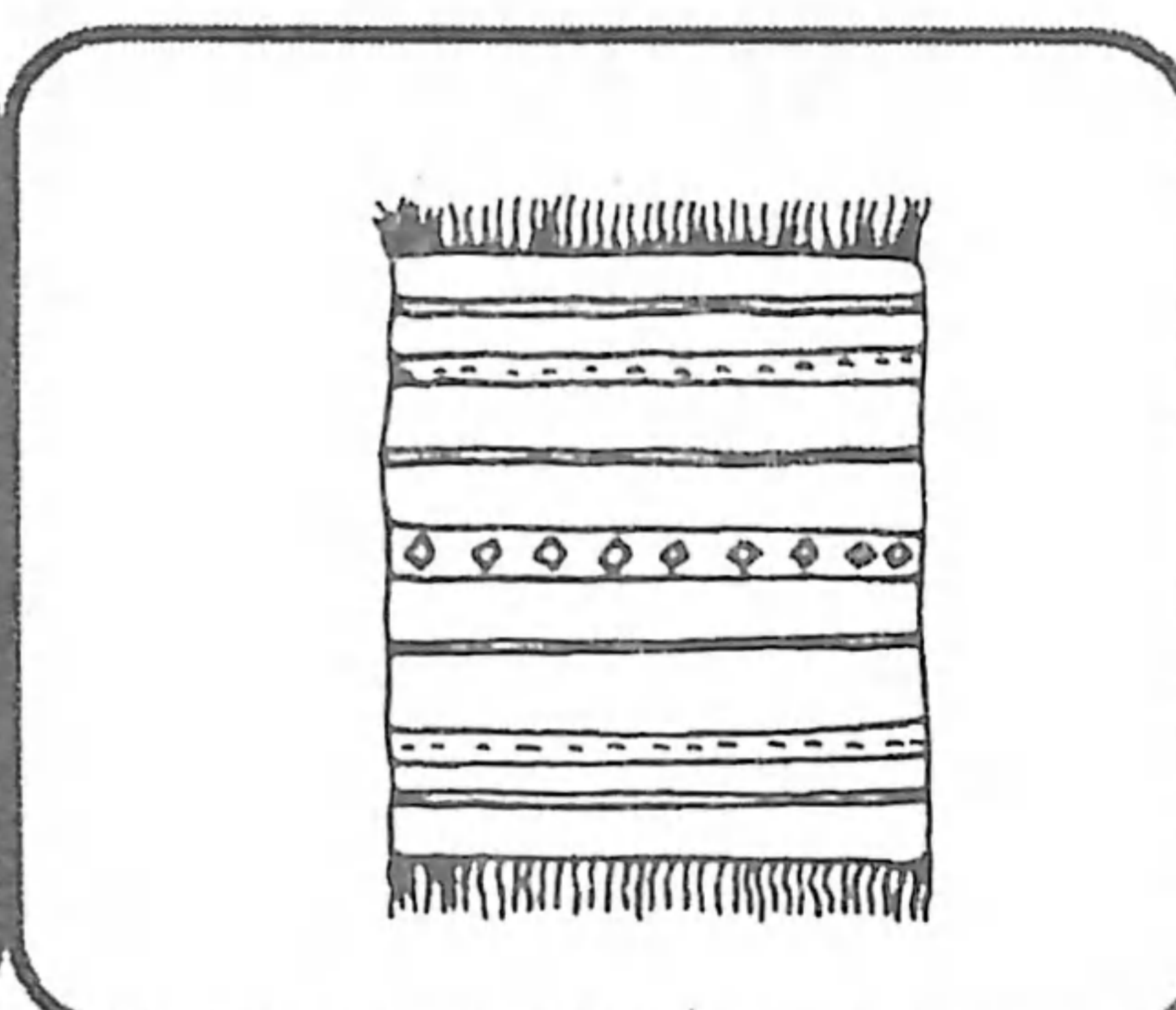

su't

Ütz tqak'utu' chi kiwäch ri tijoxela' re jalajöj tzyaqb'äl re'.

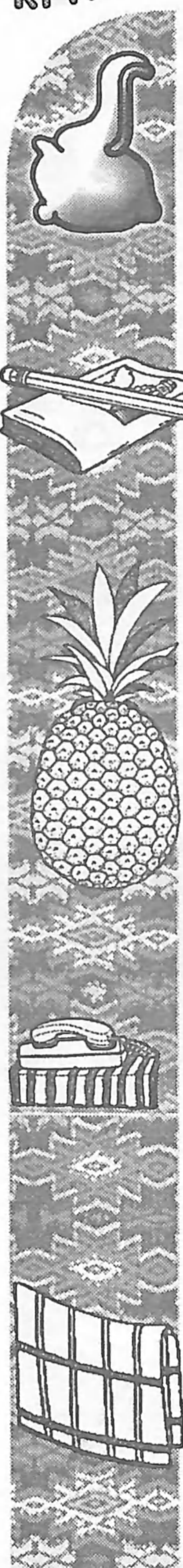

# Solojsamaj

## Tqab'onij rutzyaqb'al re jun ixöq re':

Chi xar ri ruq,  
 Chi käq ri rupo't,  
 Chi k'aqo'j ri rupas,  
 Chi q'an ri rejqab'al,  
 Chi xar chuqa' chi q'an ri ruxaq'op

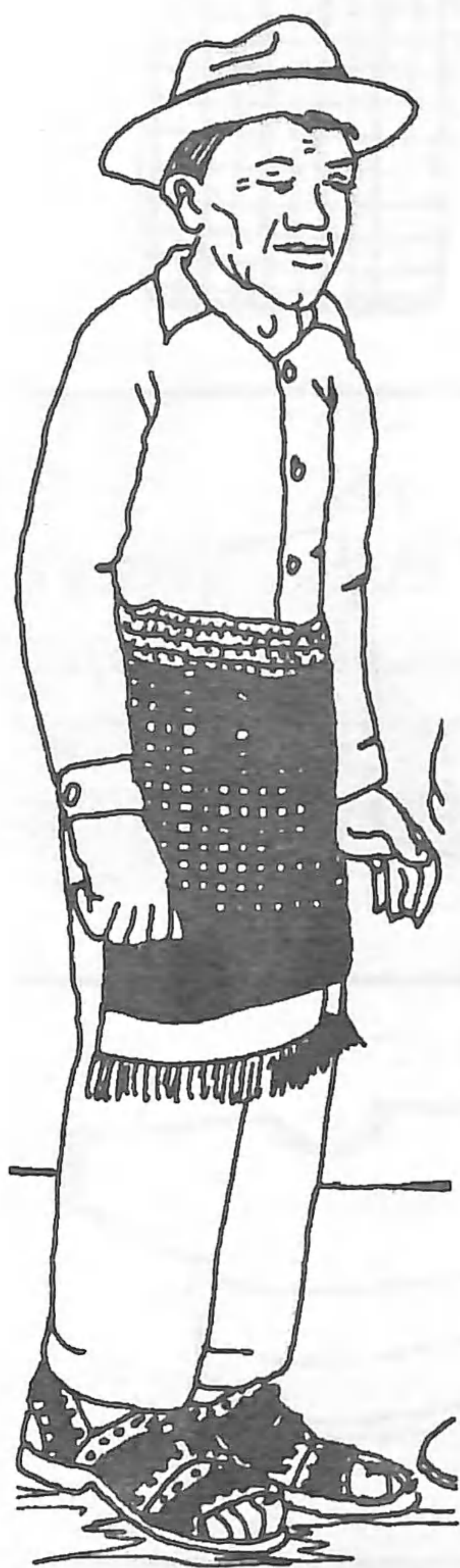
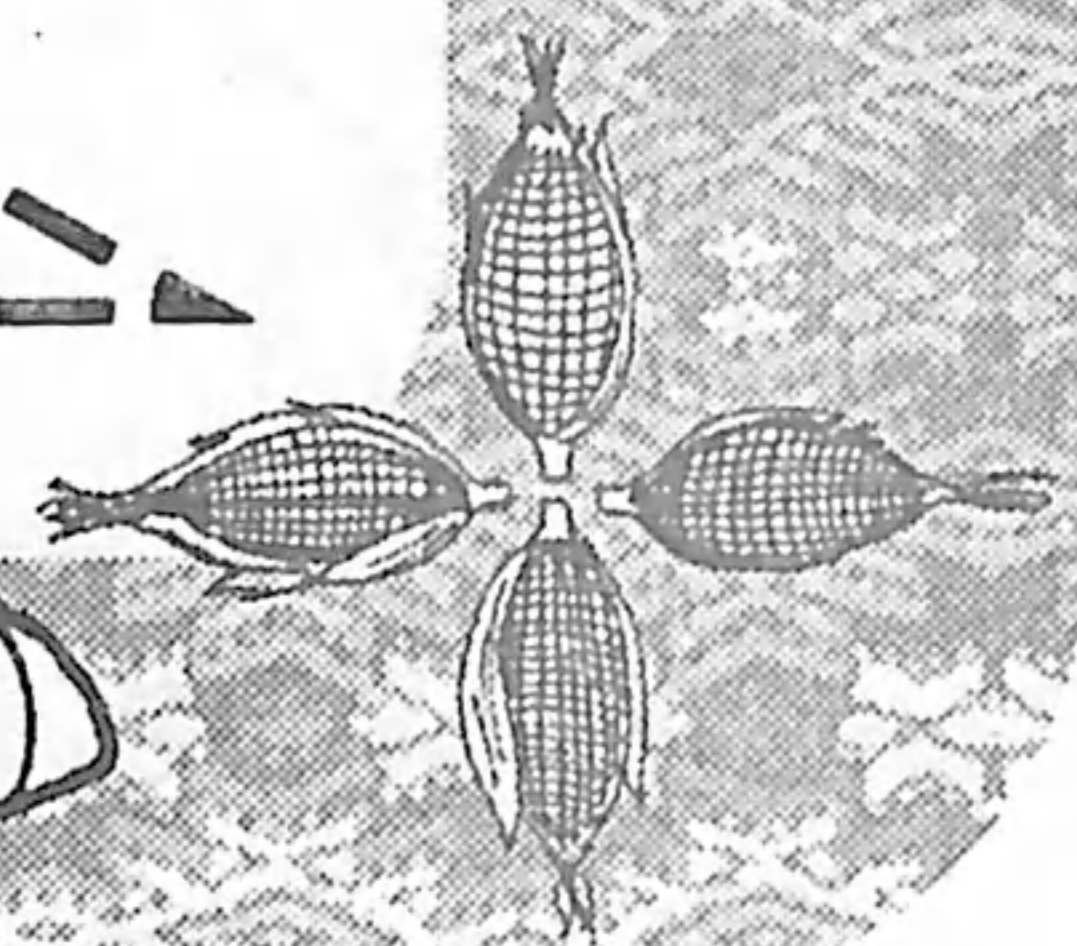
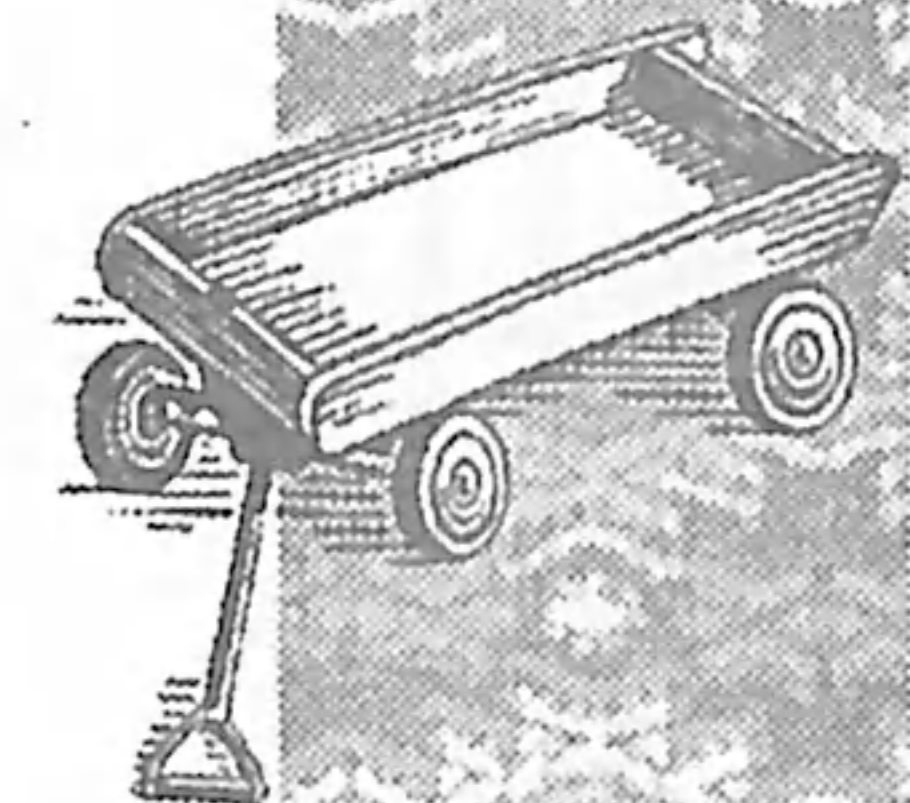

## Tqab'onij rutzyaqb'al re jun achi re':

Chi säq ri ruwex  
 Chi xar ri rukamixa'  
 Chi q'eq ri rukoton  
 Chi Käq ri ruximb'al  
 Chi q'eq rik'in säq ri ruxerka  
 Chi K'aqo'j ri ruxajab'

Ri tijoxela' k'o chi nkib'onij rupam ri kitzyaqb'al ri winaqi'.

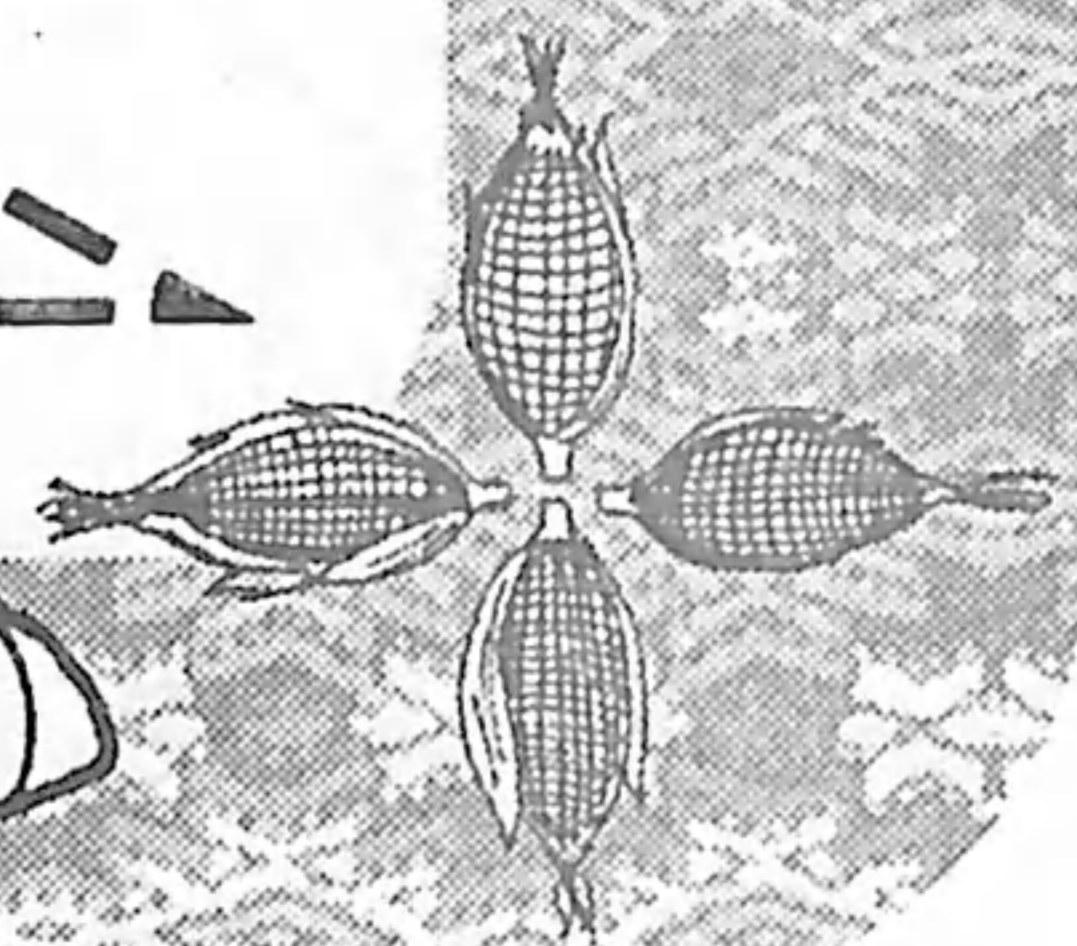



# Kojtzijon

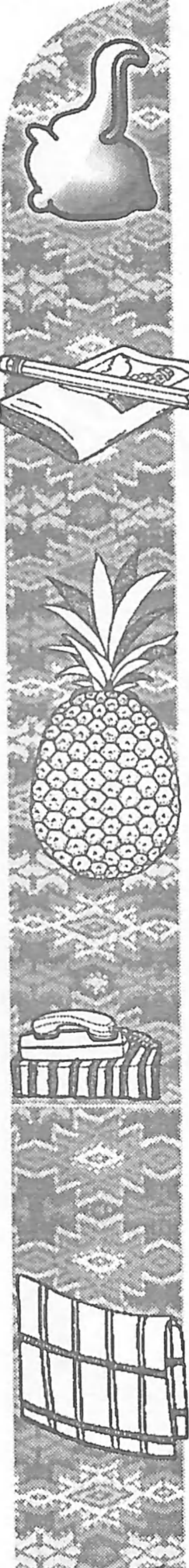

Achike xuloq' ri ate' chawe  
Jun nuwex räx rub'onil



Achike xusipaj chawe ri atata'  
jun wuq xar rub'onil

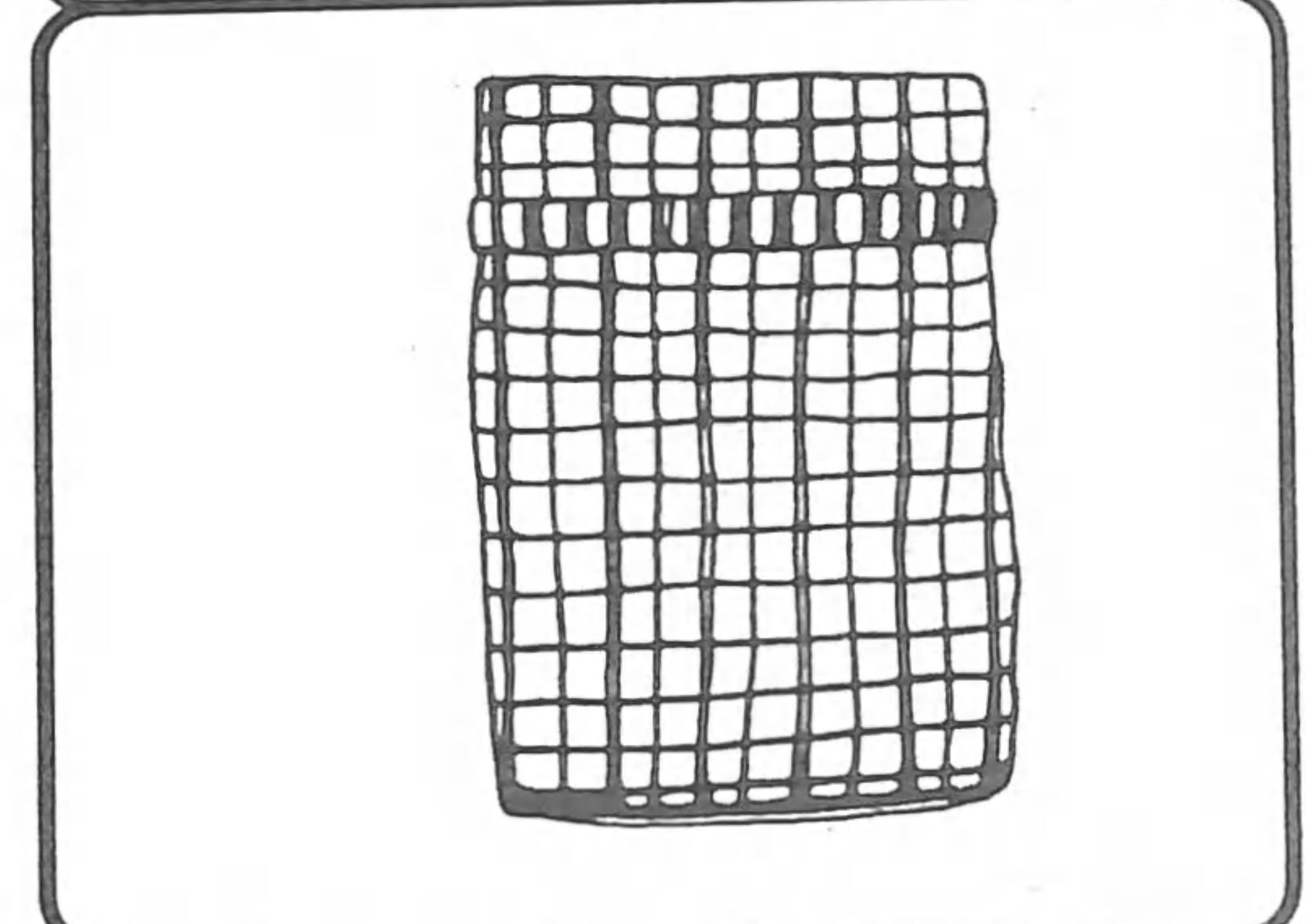

Achike xaloq' pe pa k'ayb'äl  
jun q'eq nukamixa'.



Achike xusipaj ri rute' chi re ri ak'wal  
Jun käq rukoton.

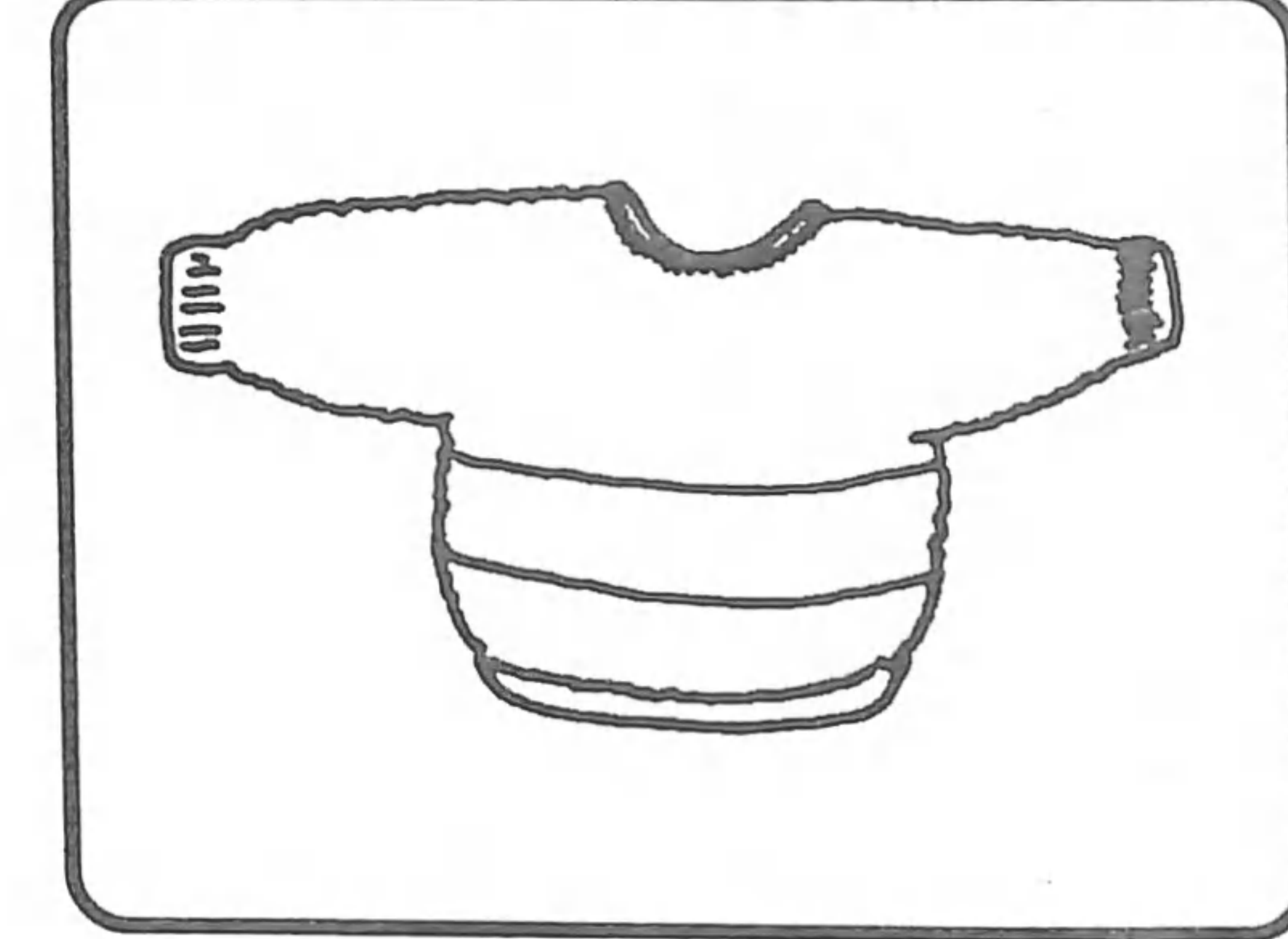

Ri tijoxela' nkikamuluj pe ri nuk'utuj ri tijonel chi ke.





Saqche': Xsaqër k'a Ixchel.  
 Ixchel: Xsaqër k'a Saqche'.  
 Saqche': La ützwäch.  
 Ixchel: Ütz nuwäch matyox. La ützwäch rat.  
 Saqche': Ütz nuwäch matyox.  
 Ixchel: Matyox k'a ri'.  
 Ixchel: Akuchi' yatb'e wi ma Saqche'.  
 Saqche': Xa yinb'e pa k'ayb'äl.  
 Ixchel: Achike k'a nab'eb'ana' pa k'ayb'äl.  
 Saqche': Xa ninb'enuloq'o' jun ruq ri wixjayil.  
 Ixchel: Ütz ri ma Saqche' tachajij awi'.  
 Saqchel: Matyox chawe.  
 Ixchel: Chwa'q chik.  
 Saqche': Chwa'q chik matyox.  
 Ixchel: Matyox k'a ri'.



Keqanuk'u' ri tijoxela' richin nqab'an re jun tzijonem re'.





# Nim, loman, Ko'öl

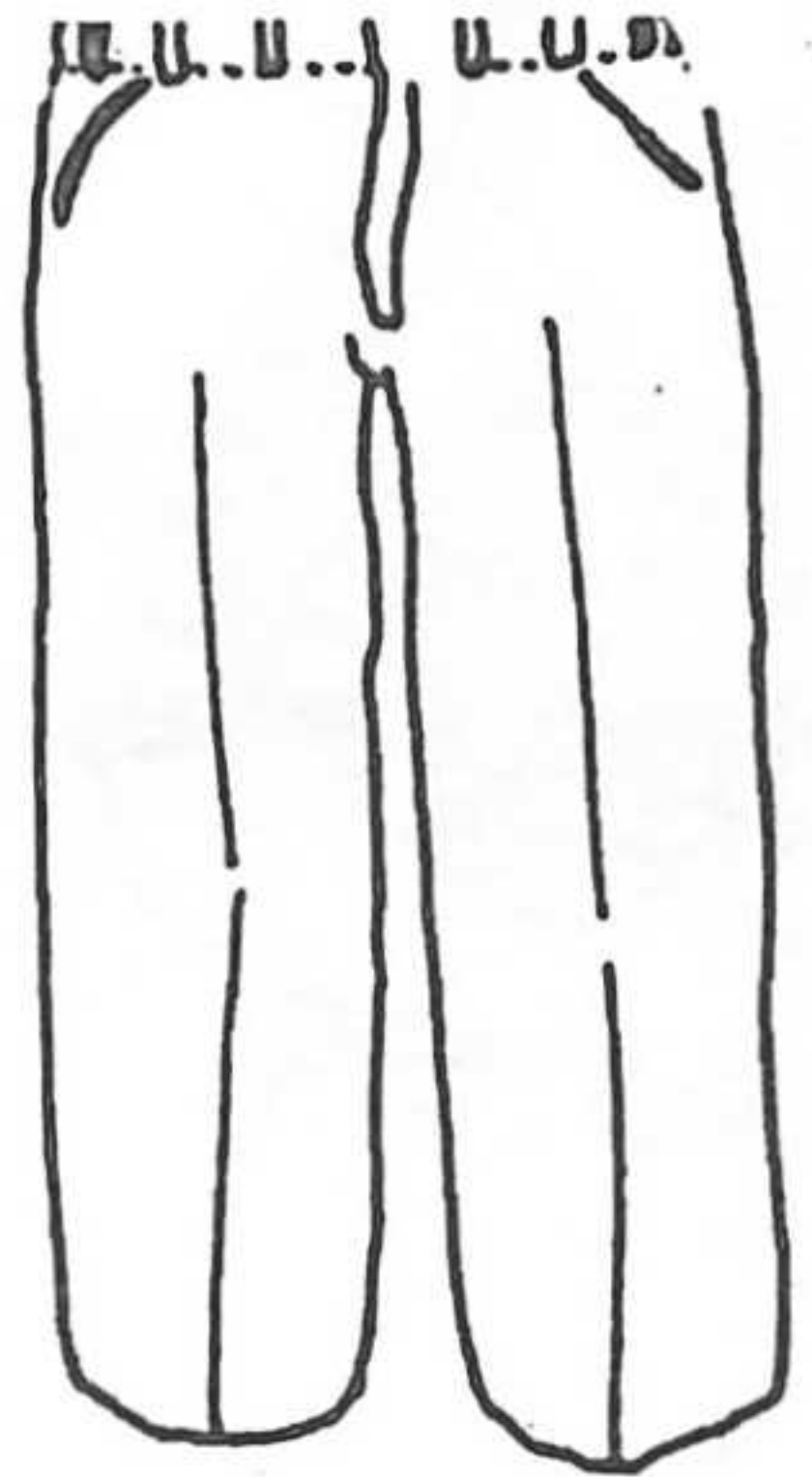

Nim



loman

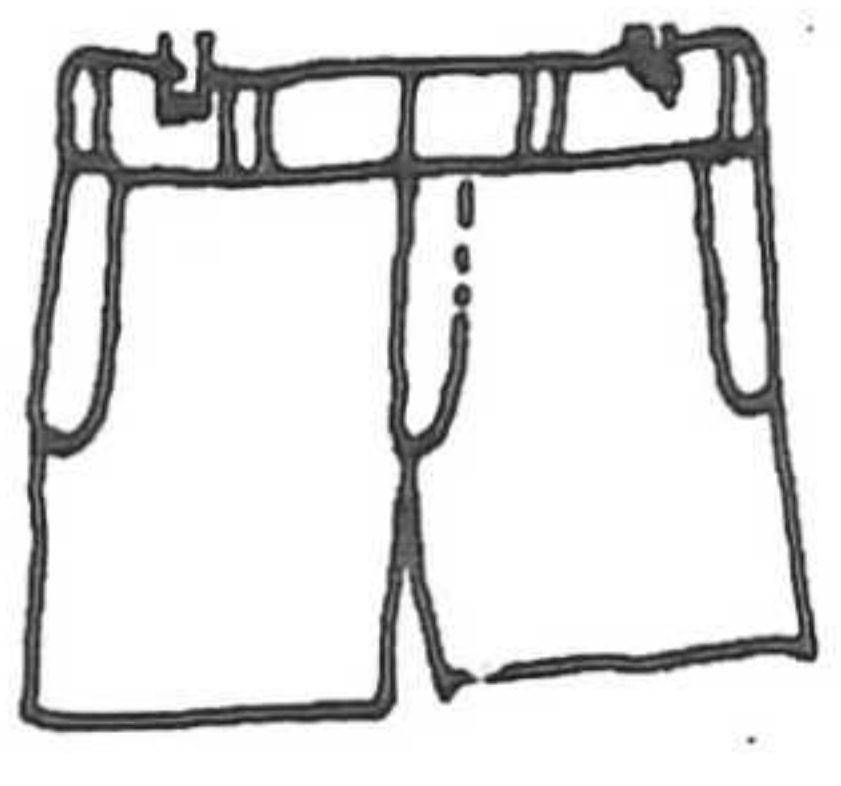

ko'öl

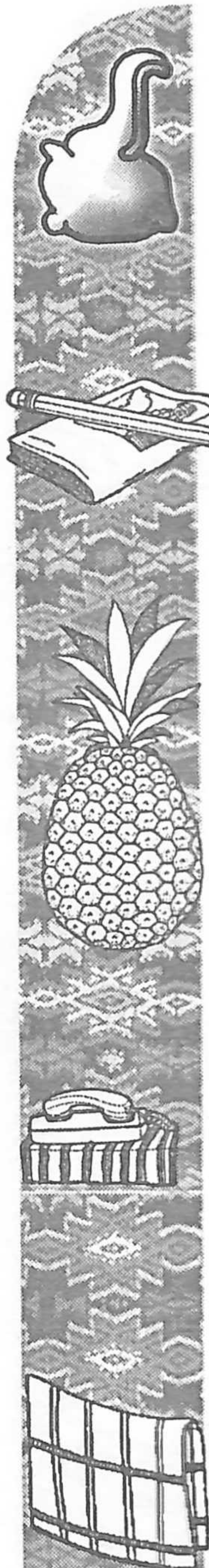

# Xax, pim, kow, b'uyül



Pim

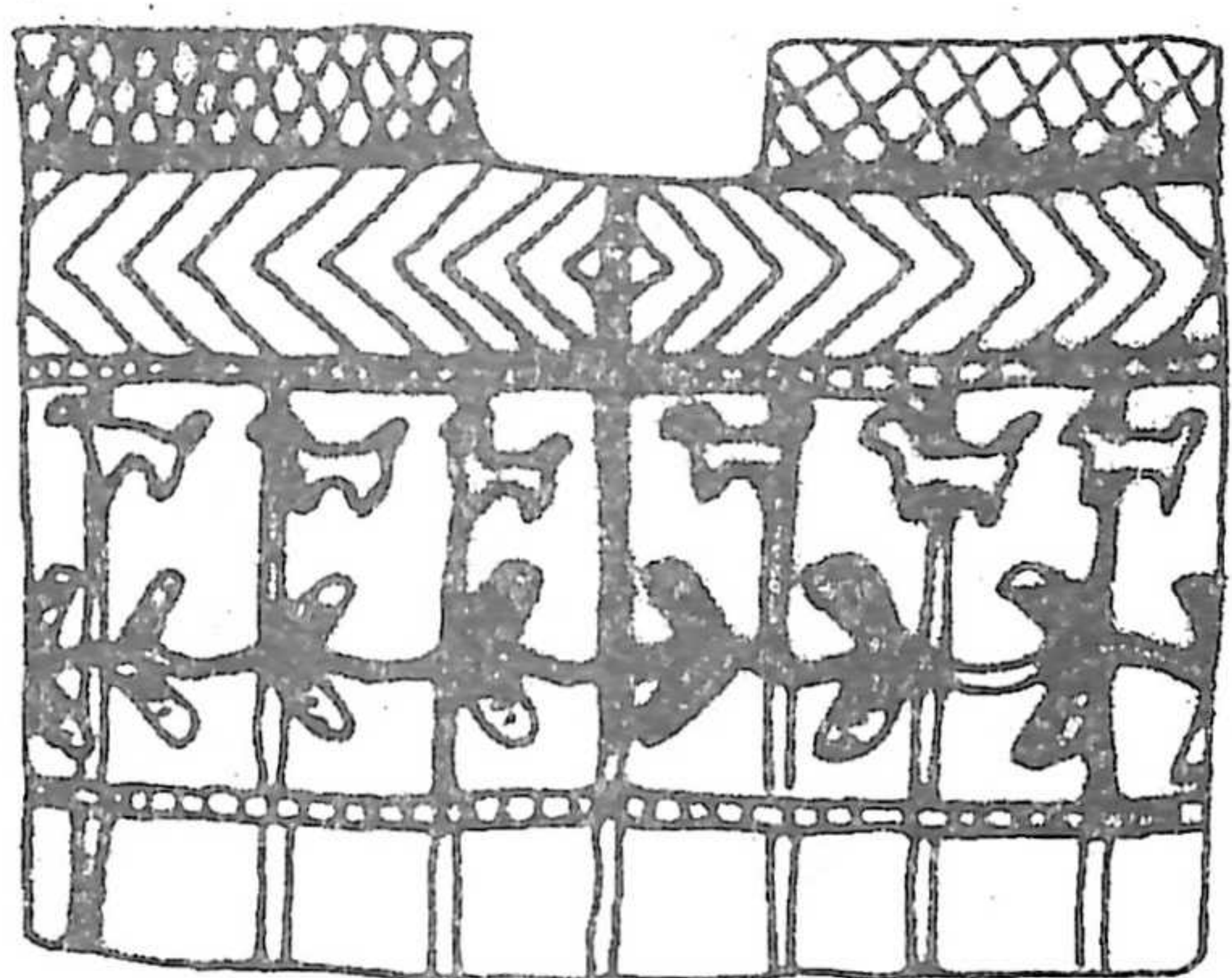

XAX

Janila nim ruwex xuloq' pe ri tat.  
Jeb'ël pim ri ruq xuloq' pe ri nan.

Ri tijoxela' tkichapa' jalajöj taq tzyäq richin nkina' ri rupimil, chuqa' nkliz'ët ri rupalen.

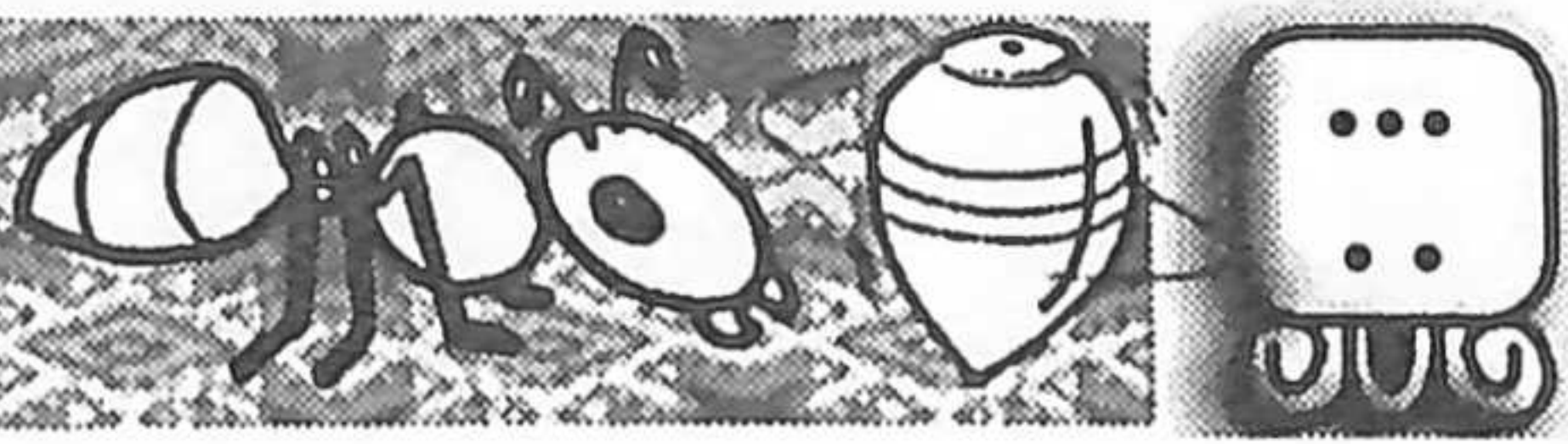

Chupam re jun ruxaq wuj re' nqab'an rachib'al jun ti  
ixtän, k'a ri' nqawiäq rik'in ruk'aj tzyäq.

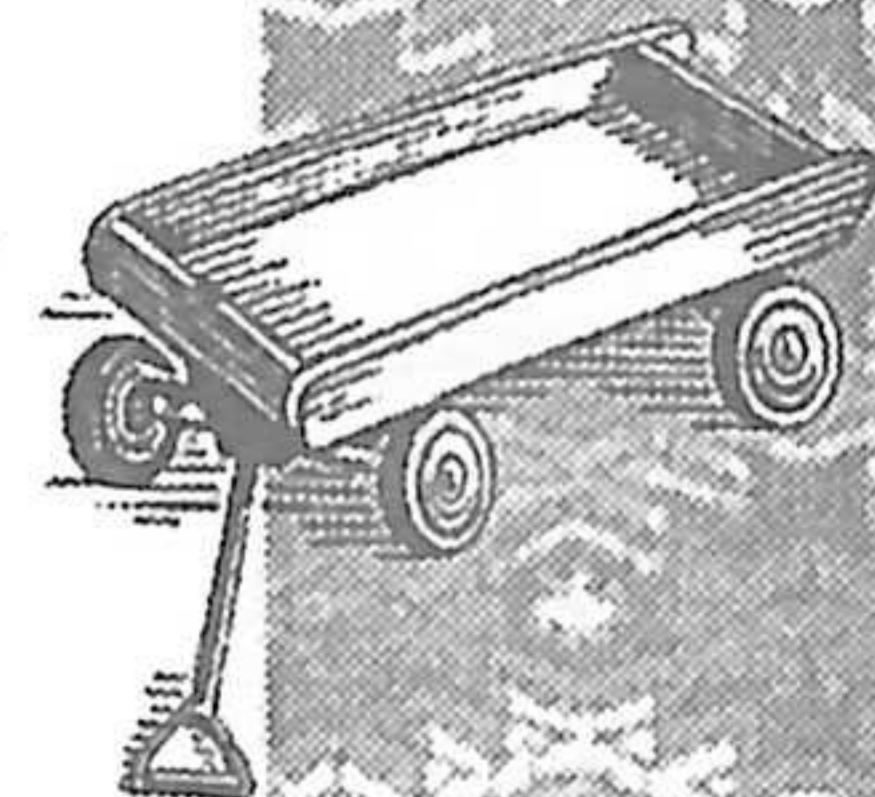
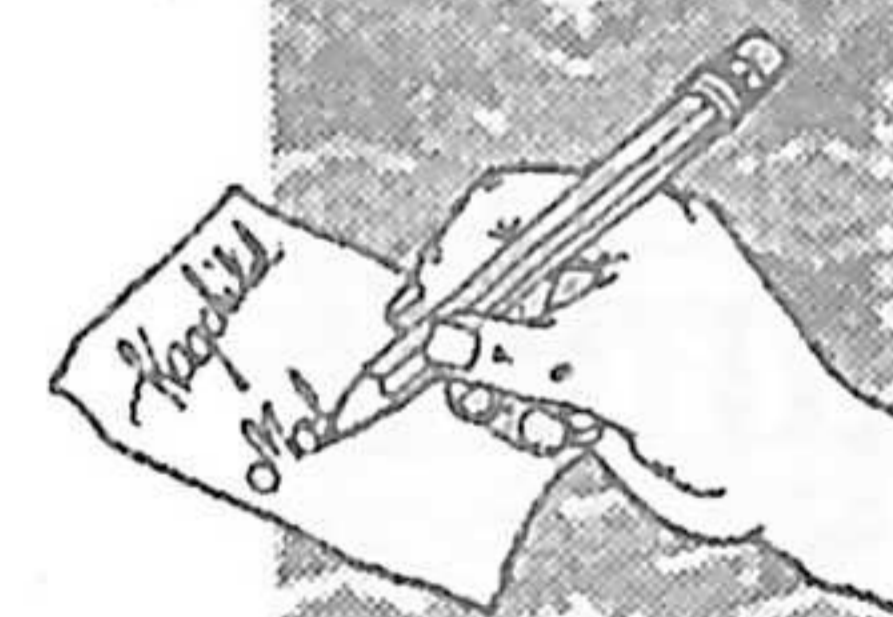

Ri tijonel keruto' ri tijoxela' richin nkib'an ri achib'al, chuqa' tuk'utu' ri  
jalajöj kib'onil tzyäq, chuqa' ri kipimil ri tzyäq ri xkik'am pe ri tijoxela'.

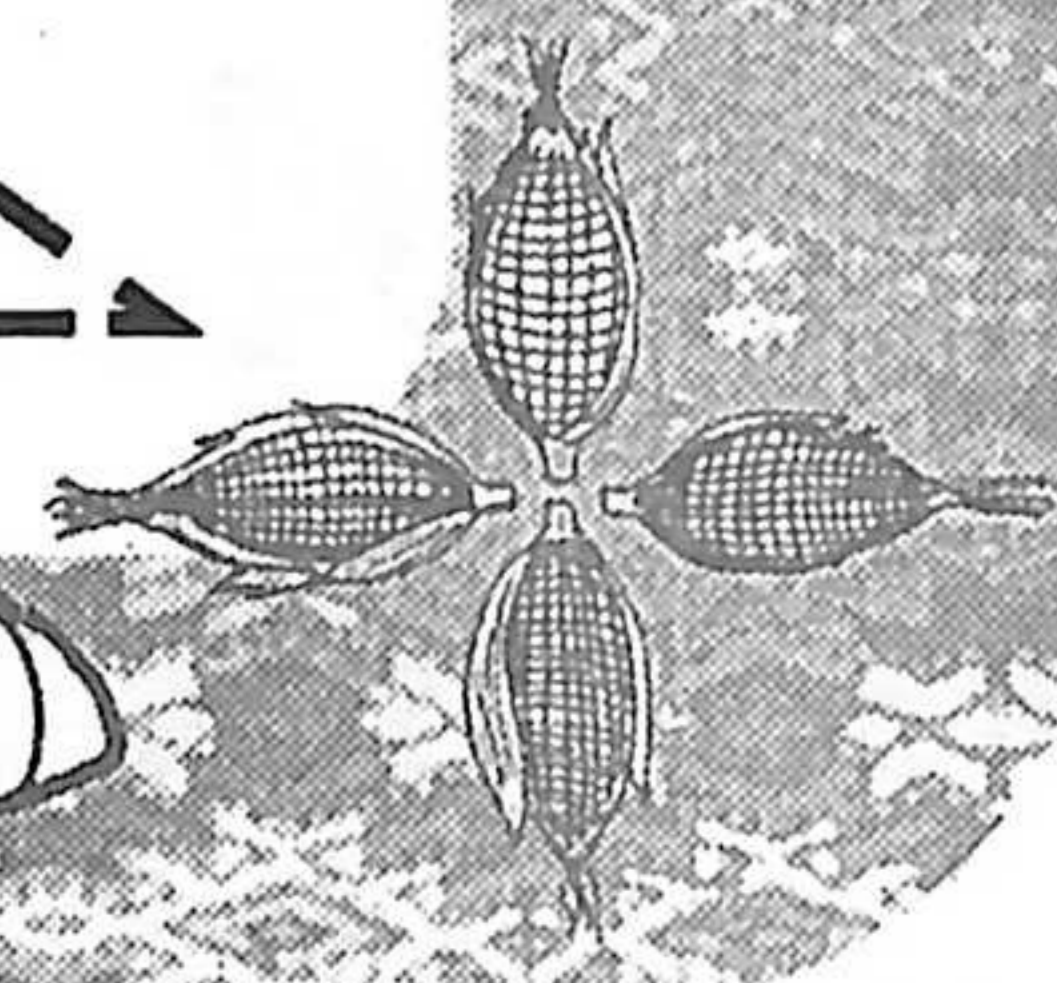
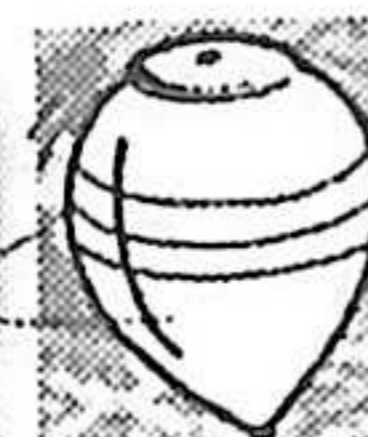
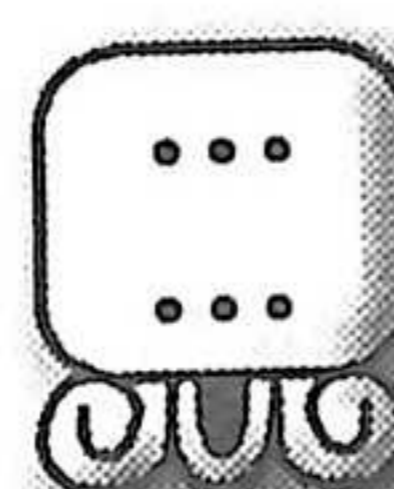





Chupam re jun ruxaq wuj re' nqab'än rachib'äl jun ti ala', k'a ri' nqawiq rik'in ruk'aj tzyäq.

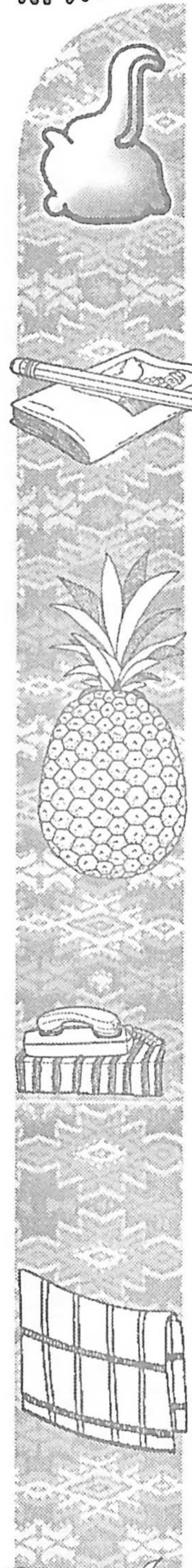

Ri tijonel keruto' ri tijoxela' richin nkib'än ri achib'äl, chuqa' tuk'utu' ri jalajöj kib'onil tzyäq, chuqa' ri kipimil ri tzyäq ri xkik'am pe ri tijoxela'.

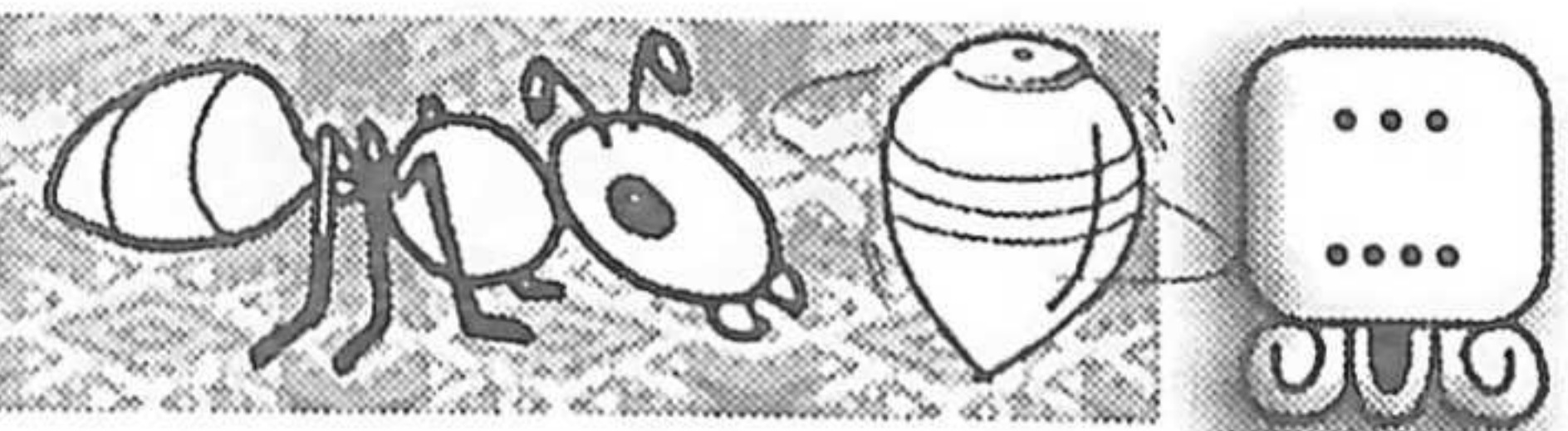

# Ri tijoxela' yetzijon pa ruwi' re jun achib'äl re'

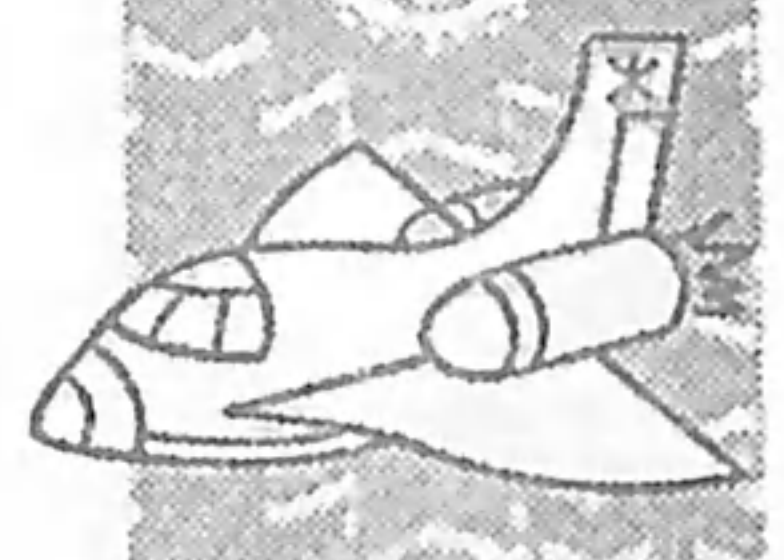
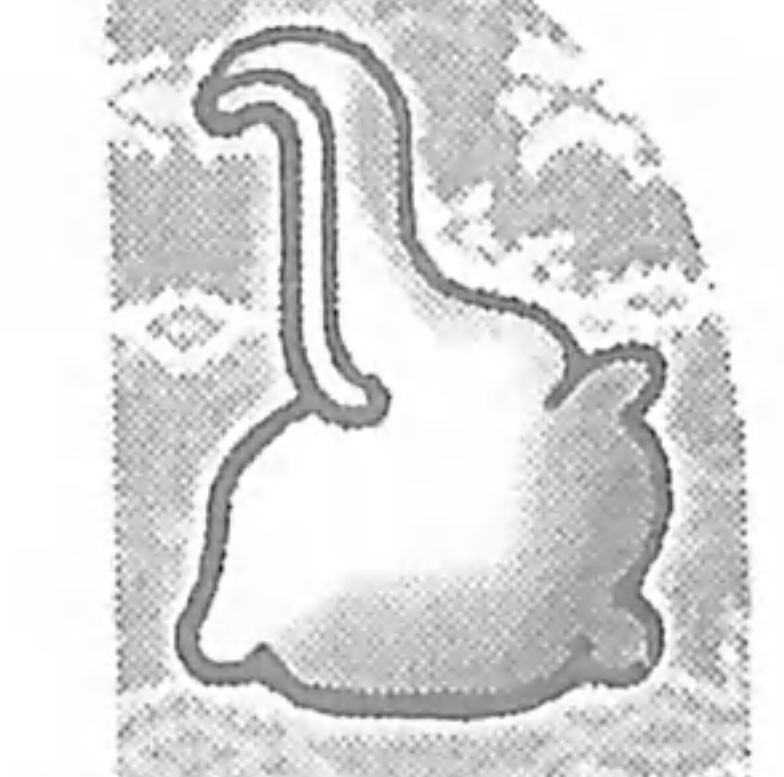

Blank writing area with horizontal lines and a pencil icon at the bottom right.

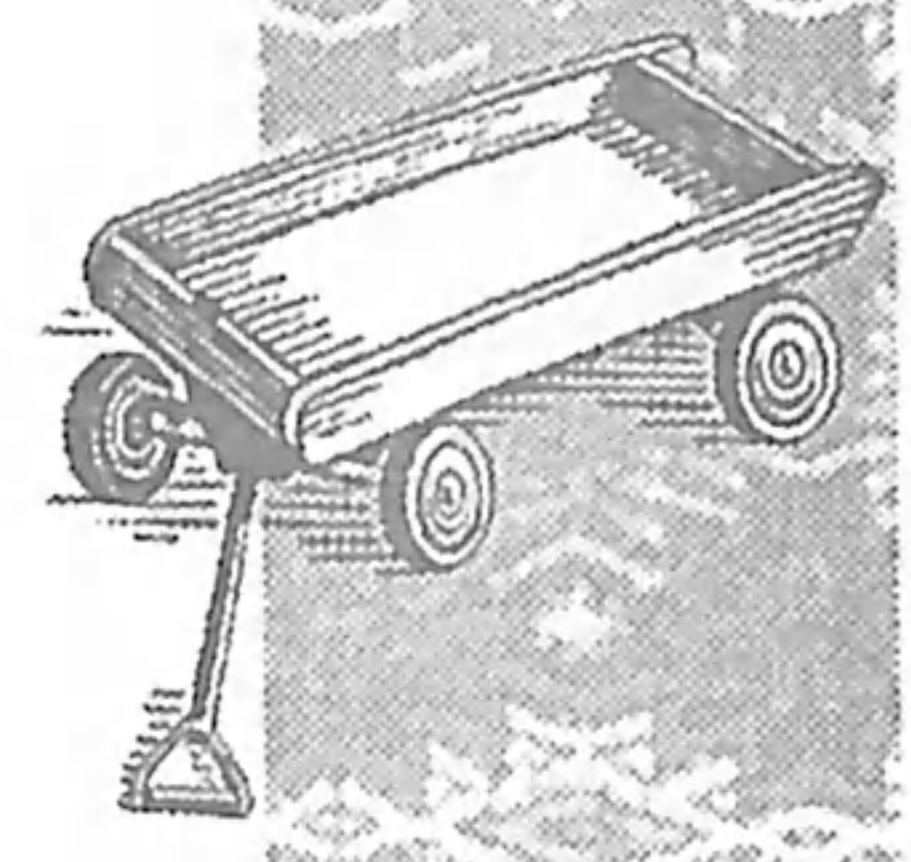

Ri tijoxela' yetzijon pa ruwi' ri nkitz'ët chupam ri achib'äl.



# Tojtob'enik



Ri Xinwetamal

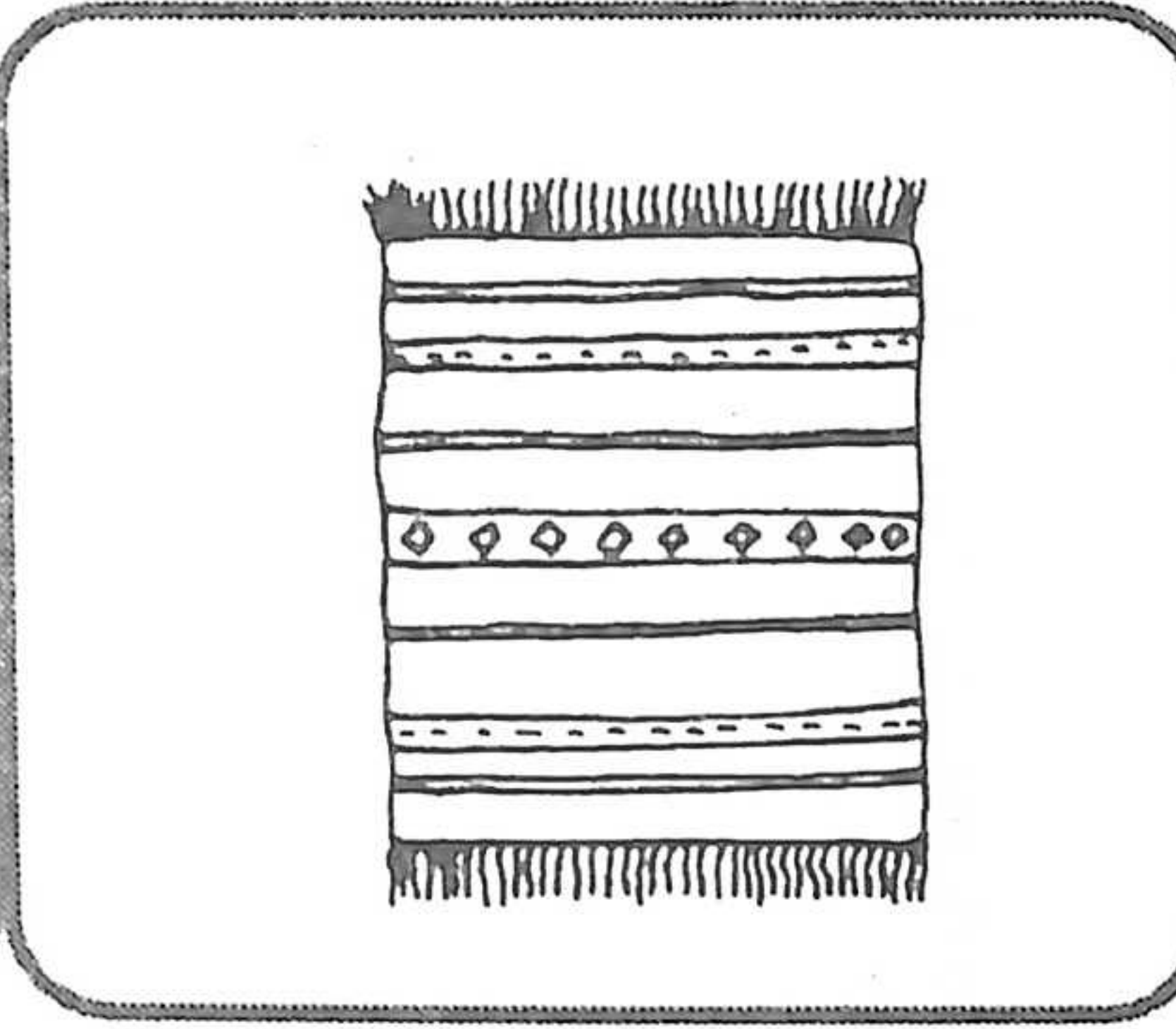
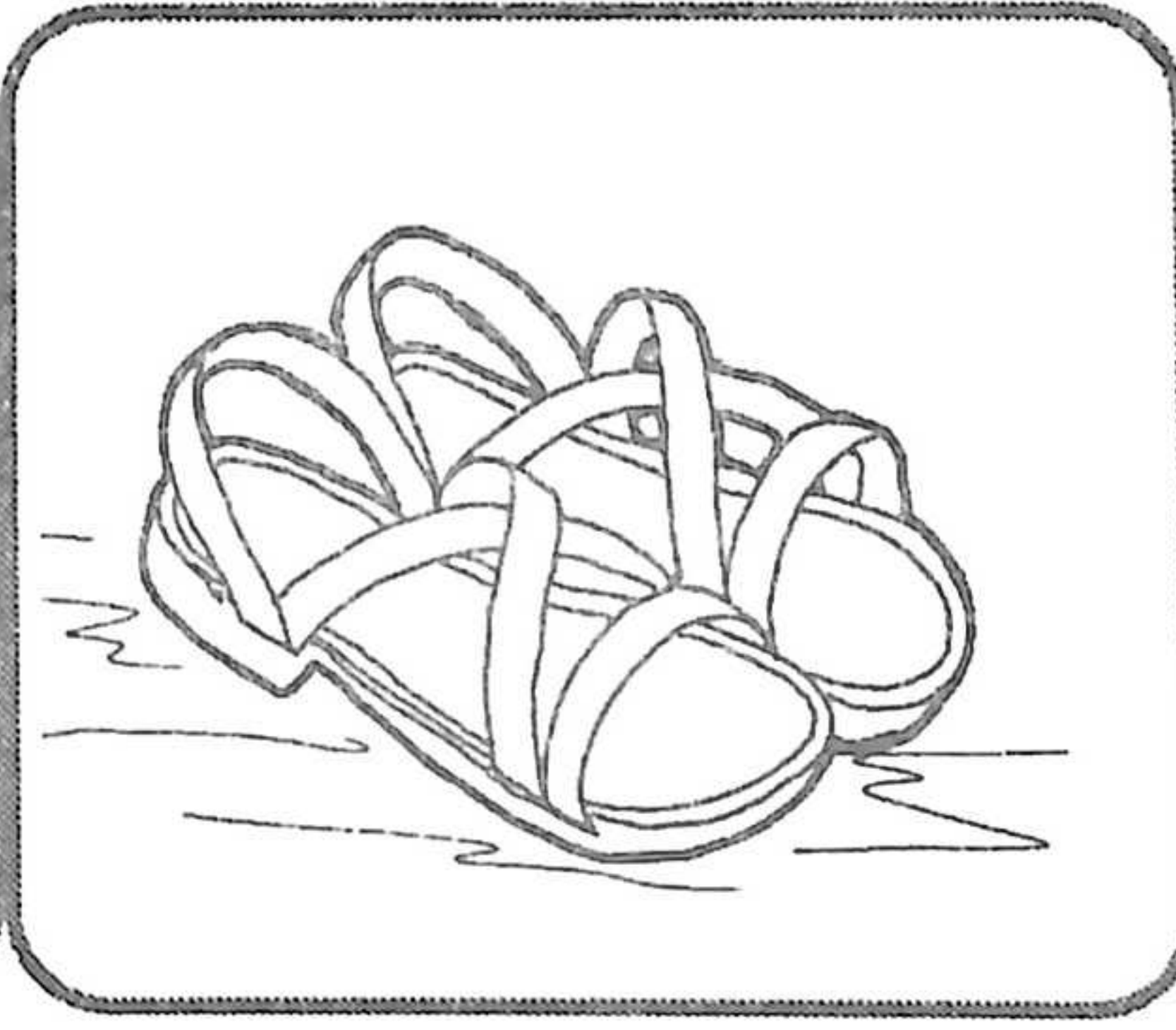
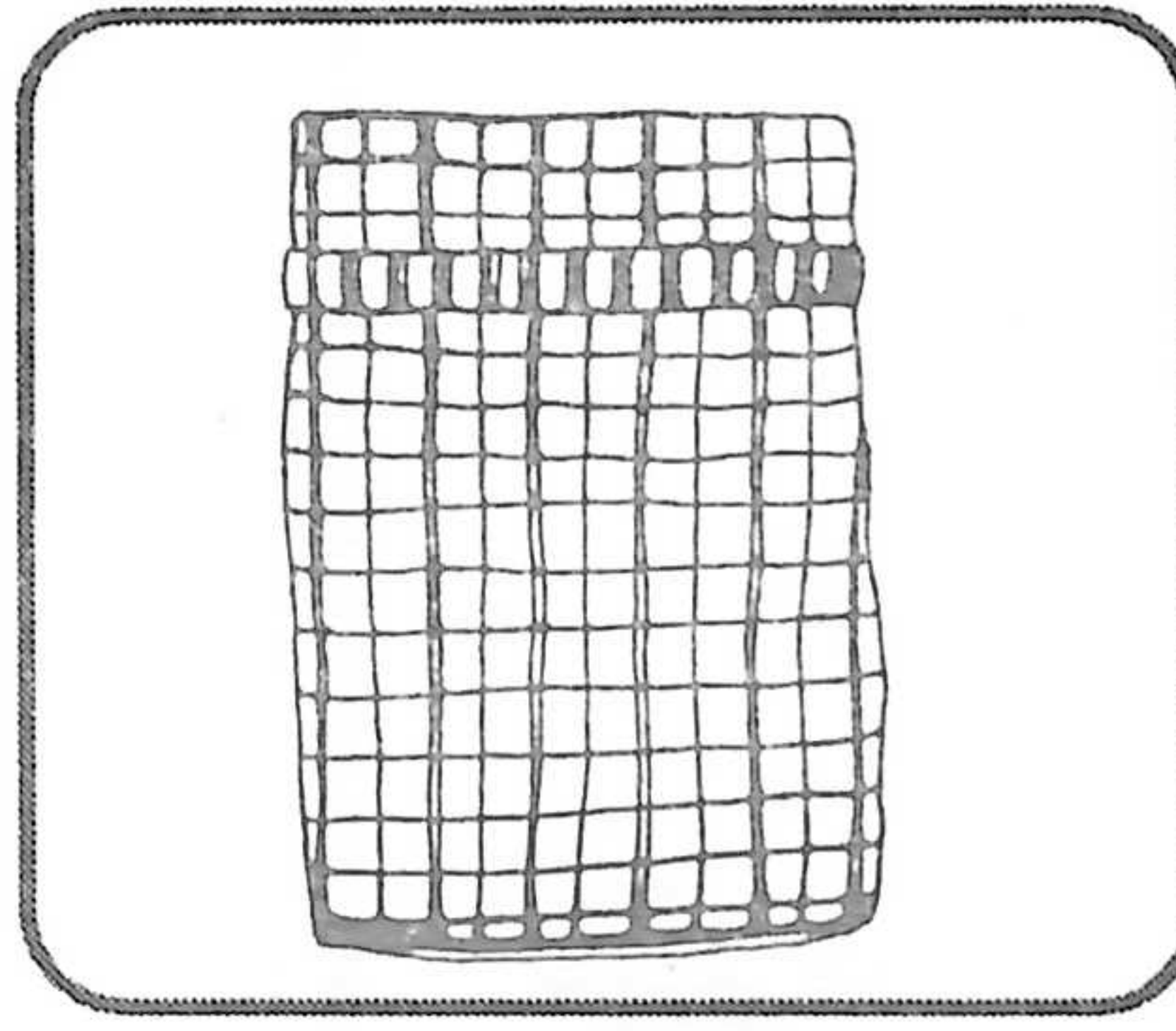
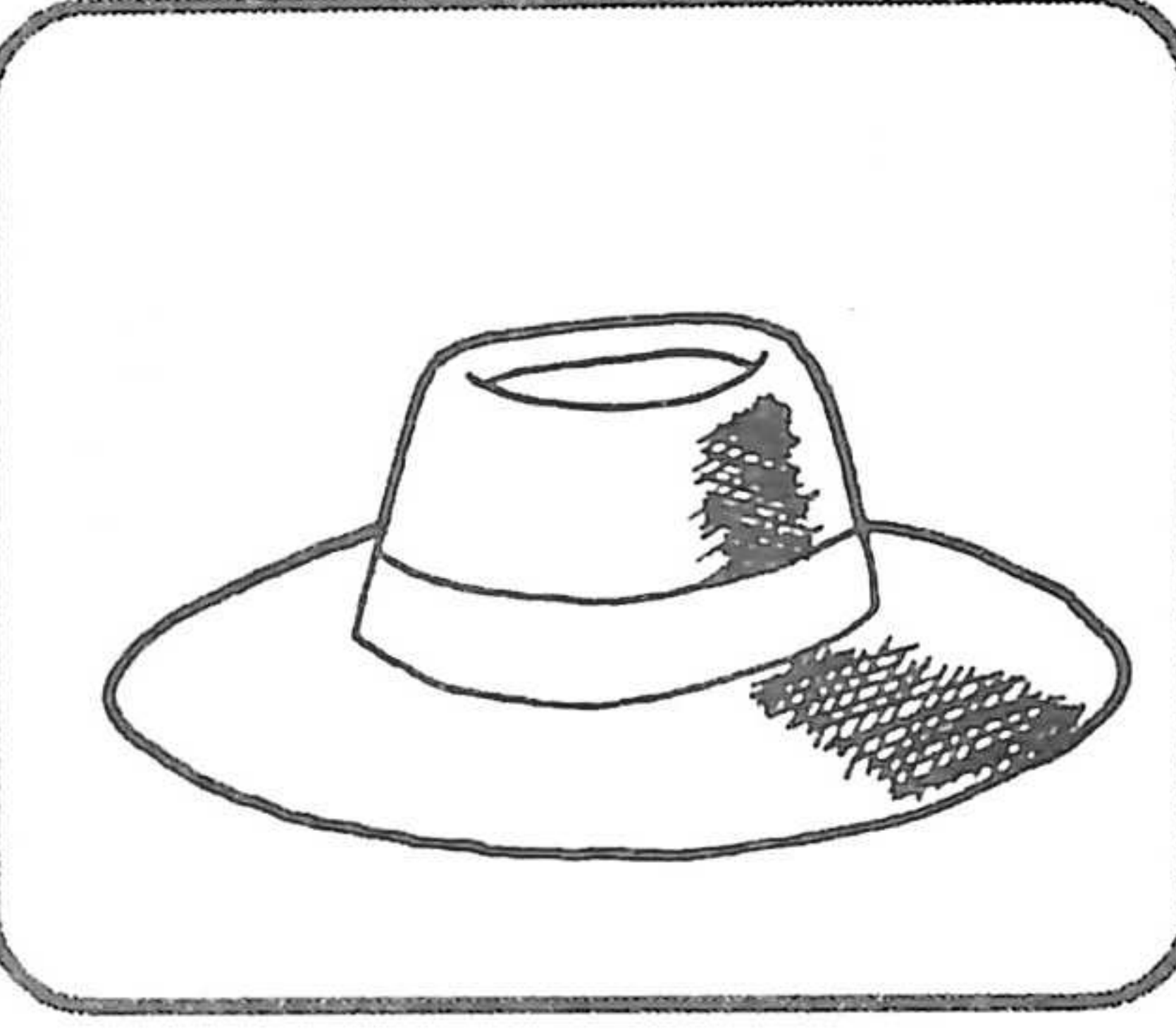
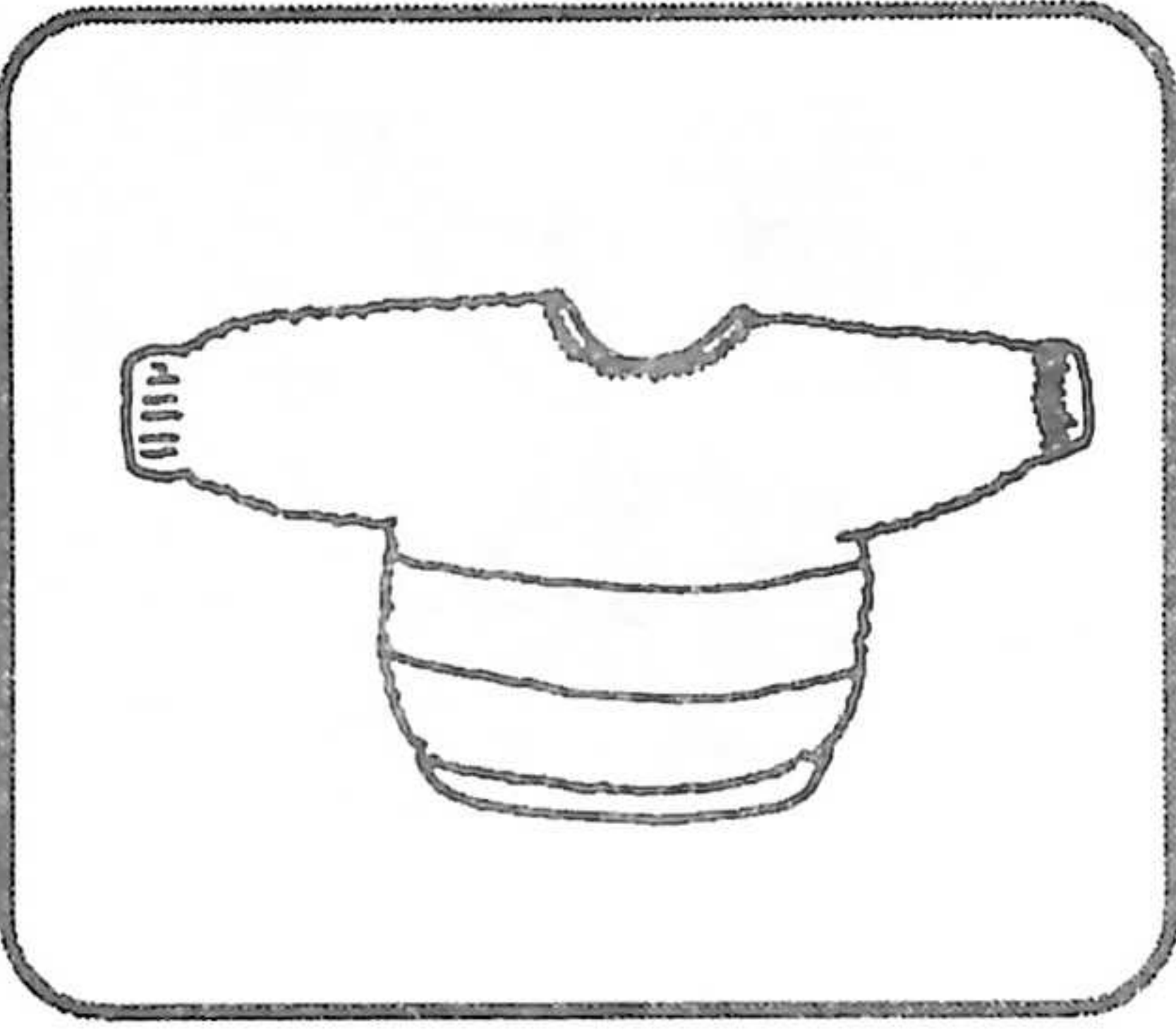
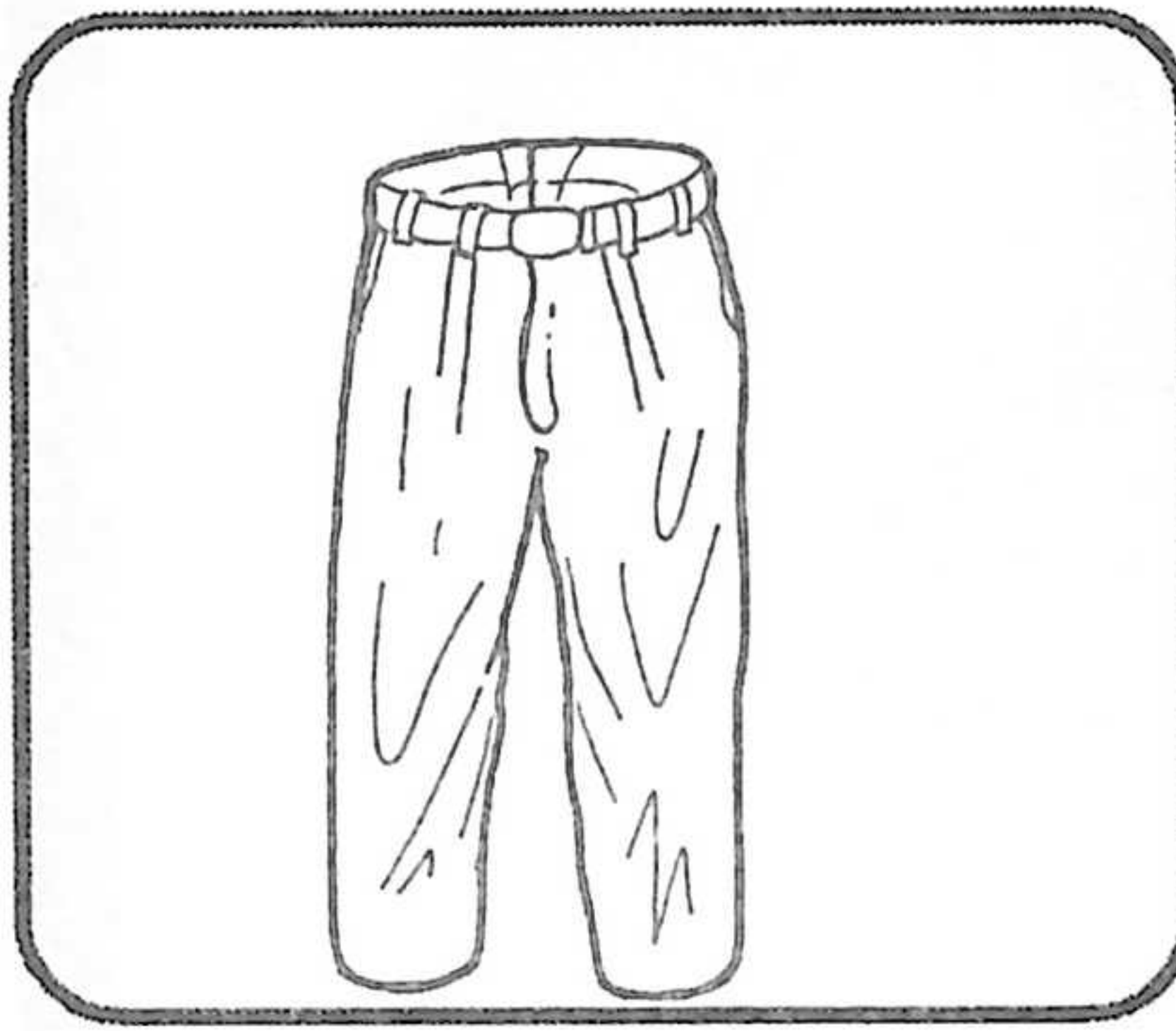
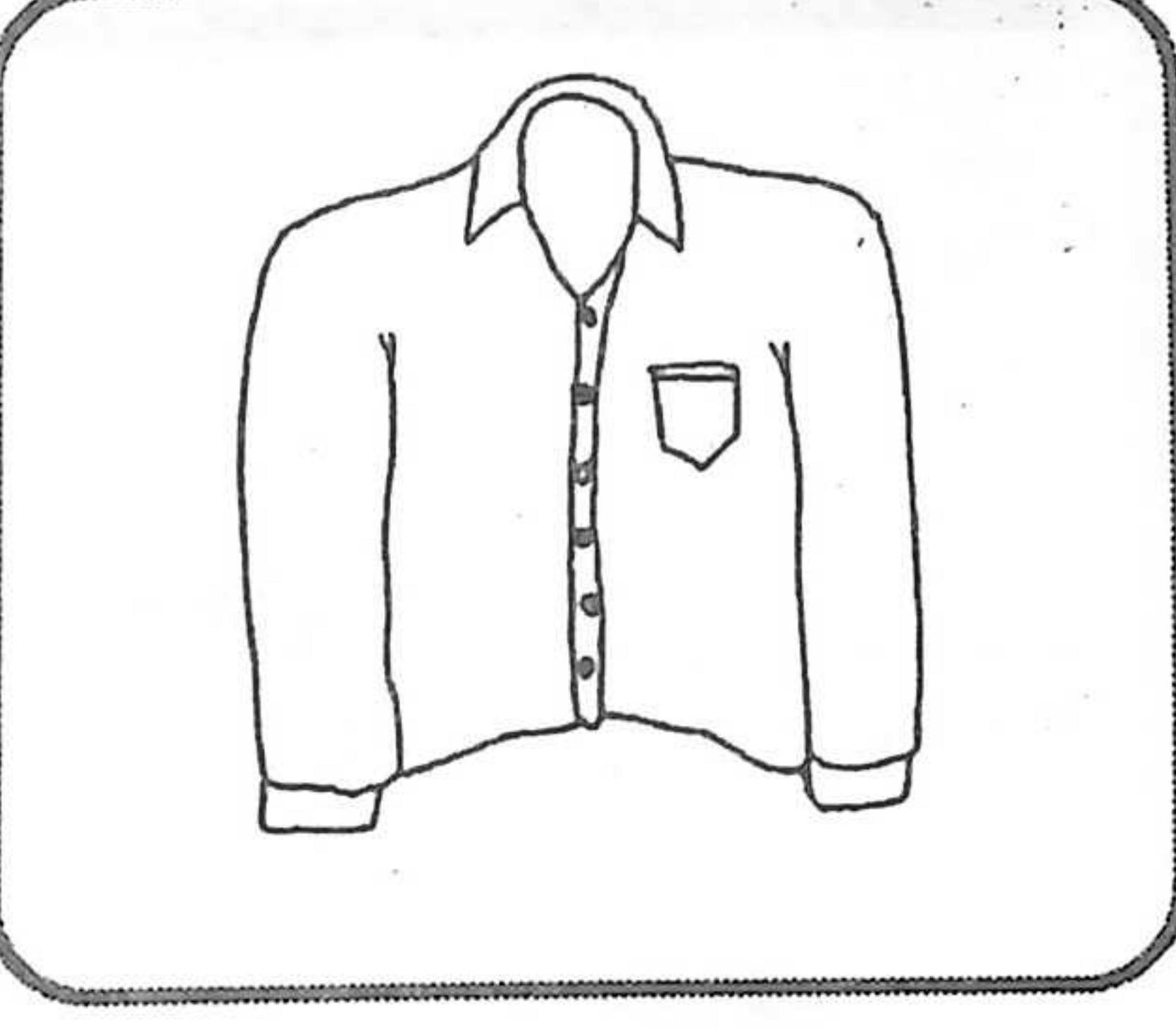
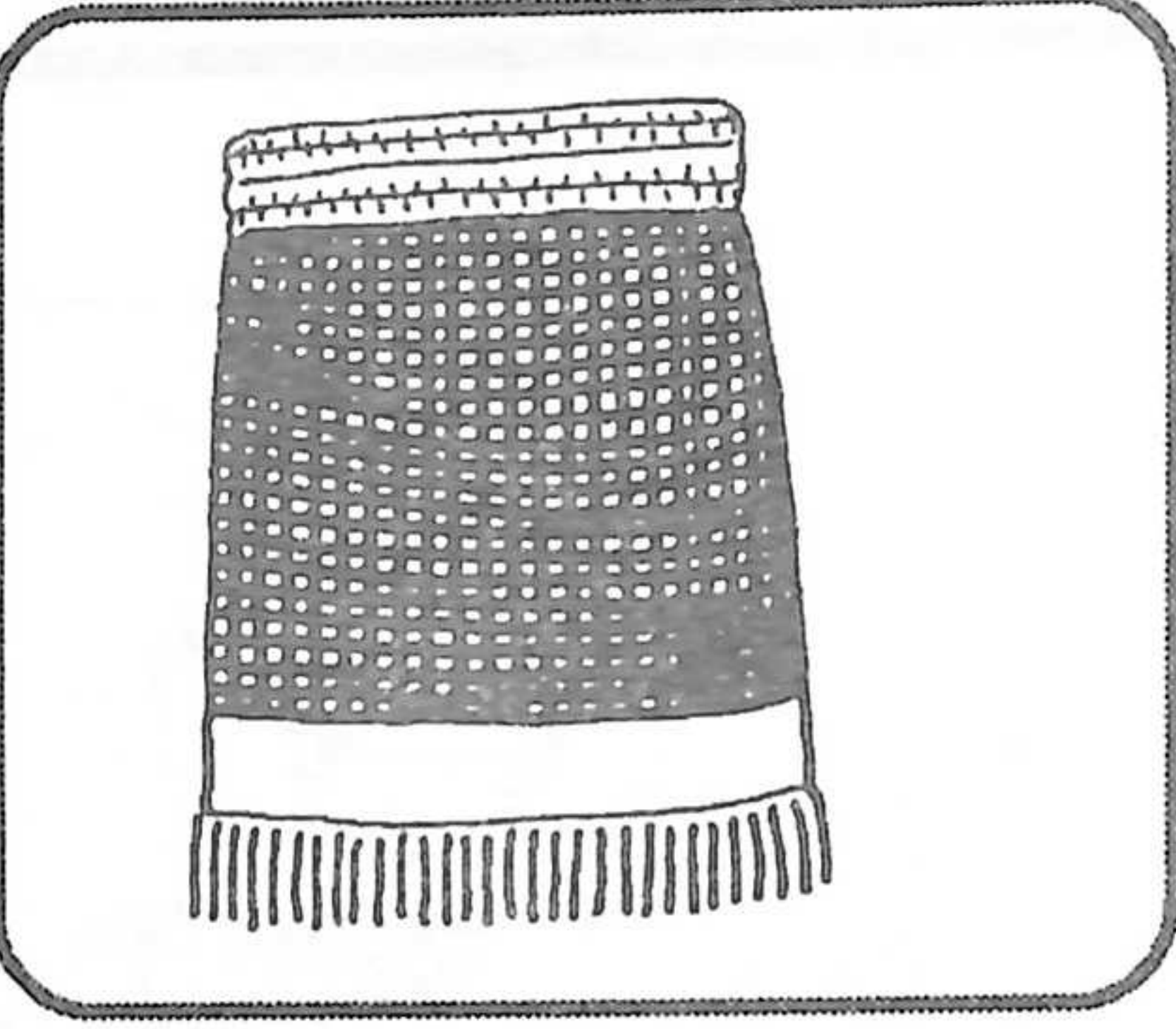
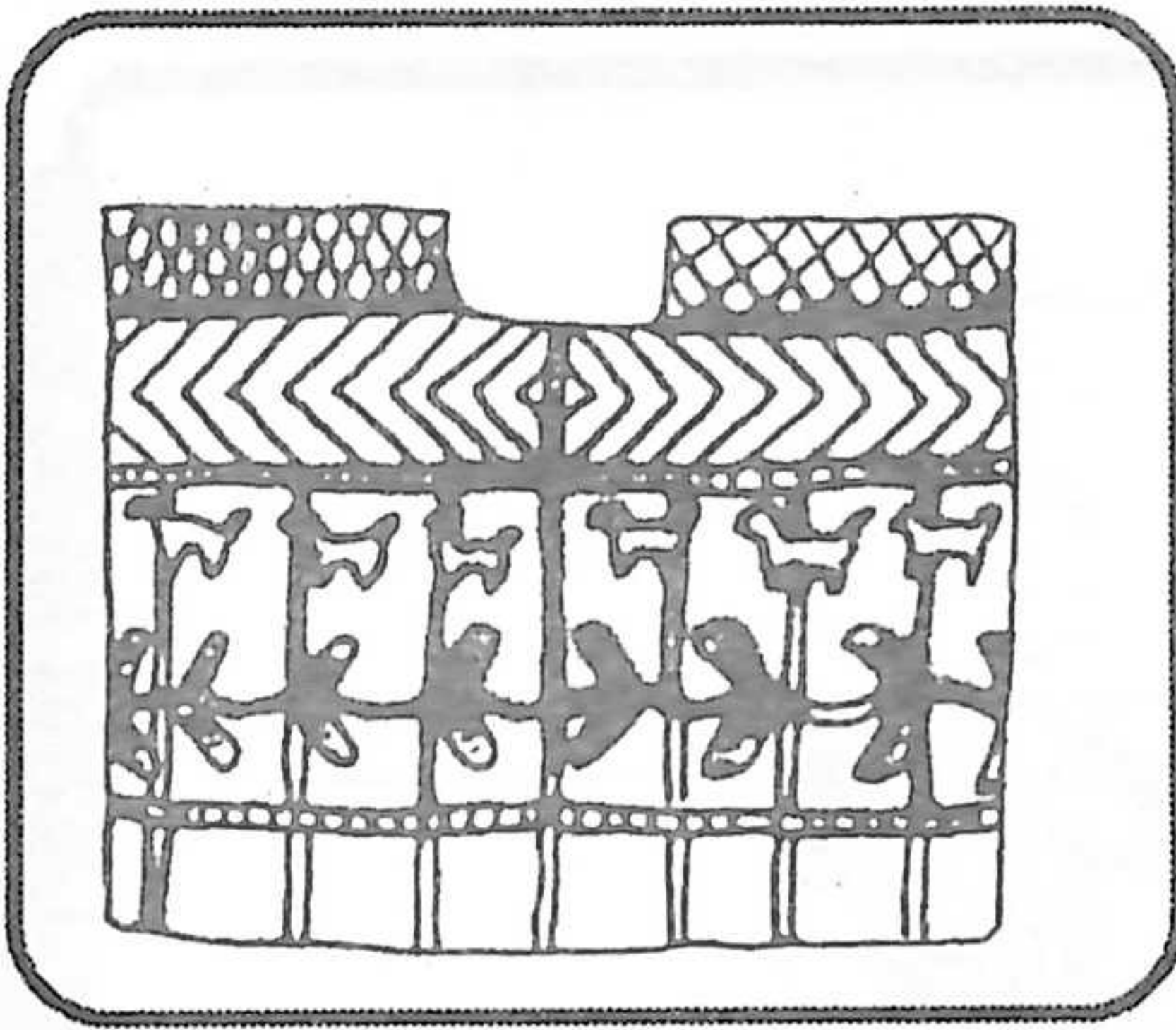
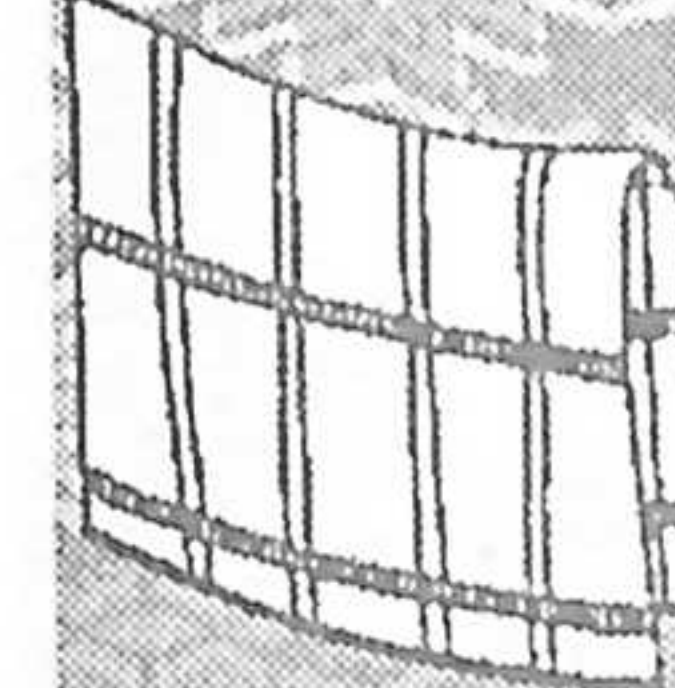

Ri tijoxela' nkitz'ib'aj kib'i' ri jalajöj tzyaqb'äl



# RUWAQ TANAJ

## Ri qach'akul



### Ri etamanik nuq'i' ri tijoxel:

Ri tijoxela' ketaman. rub'i' jujun peraj ri ruch'akul.  
Nretamaj ri nk'atzin jujun peraj richin ri ruch'akul.  
Nretamaj ri jalajöj ruk'ojlemal ri ruch'akul.

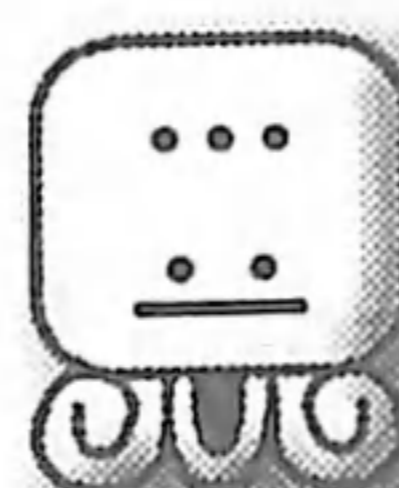
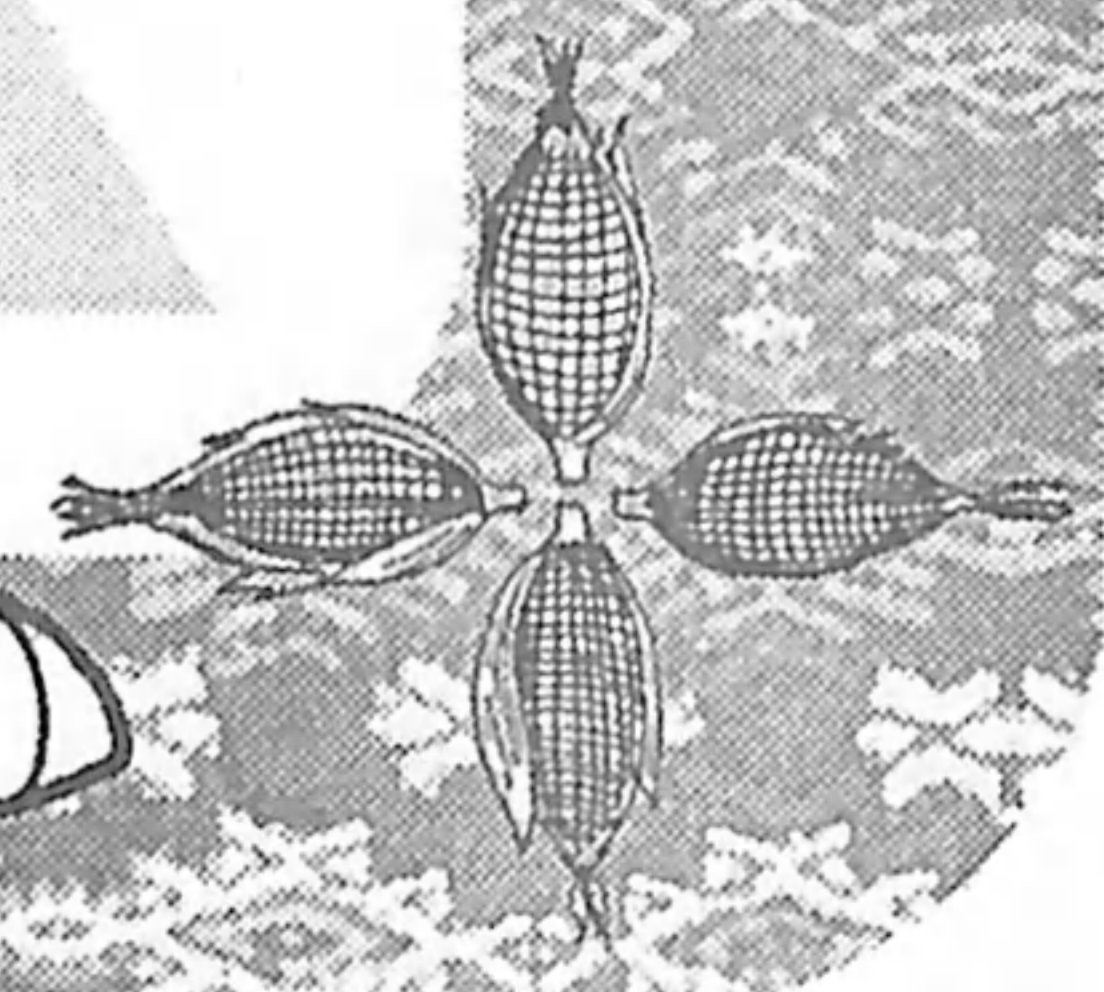
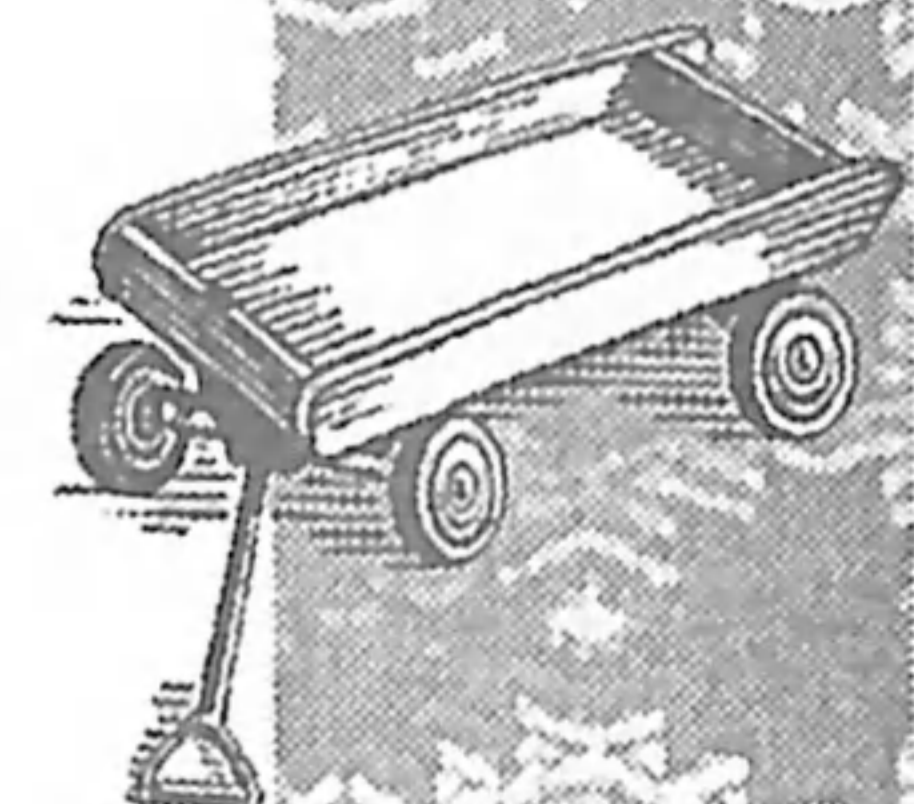



Chupam re jun ruxaq wuj re' nqab'än rachib'äl jun winäq richin nqaya' kib'i' ri rupam ruch'akul.

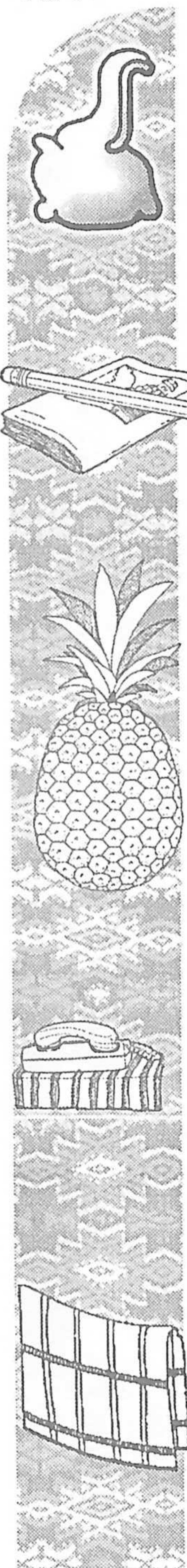
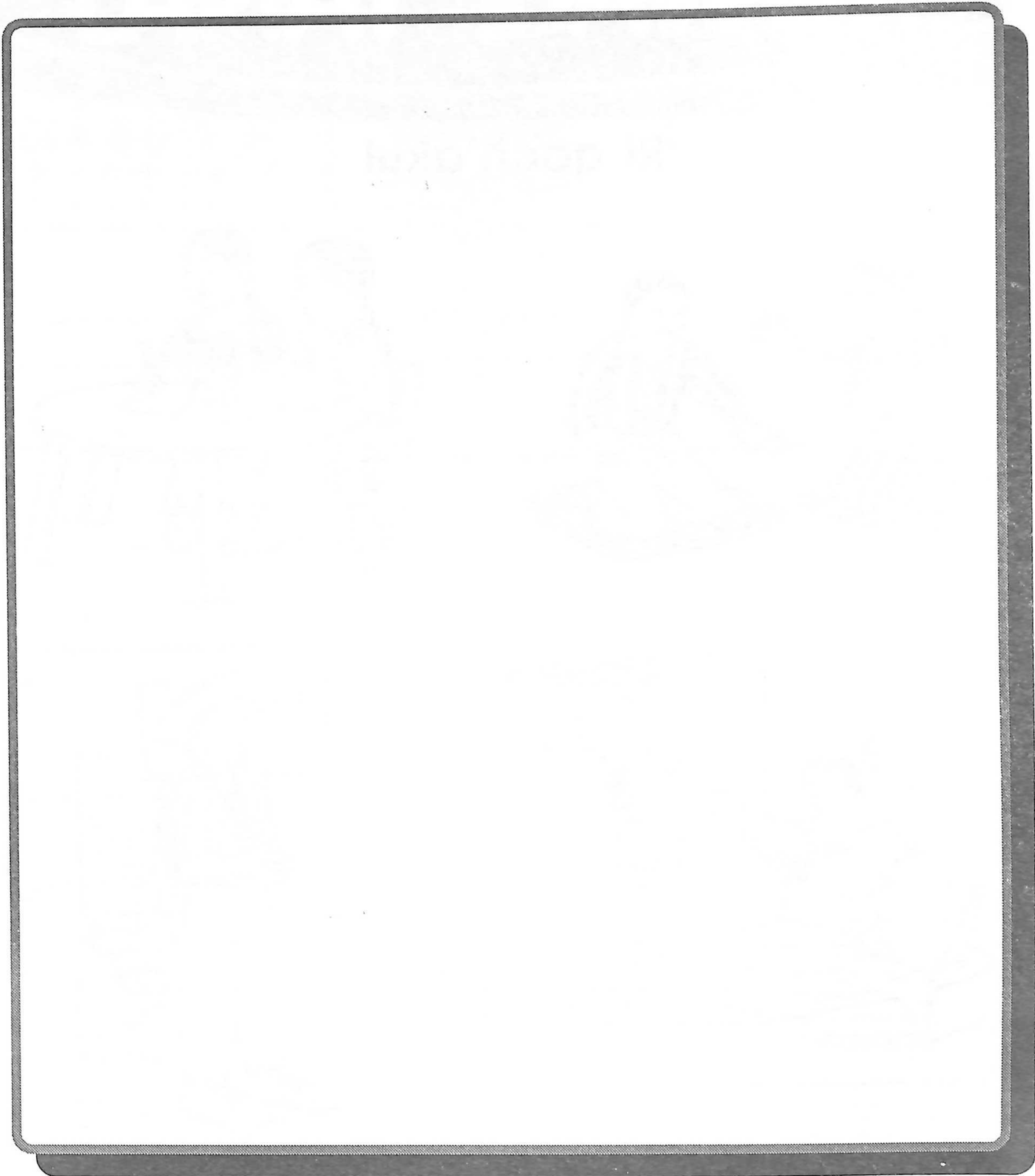

Ri tijonel nujäch chi kiwäch ri tijoxela' jun ruxaq wuj, chuqa' jun achib'äl ch'aron pa waqi' peraj. Ri tijoxela' nkitz'arab'a' chuwäch ri wuj ri jujun peraj richin nkipab'a' jun ch'akulaj.

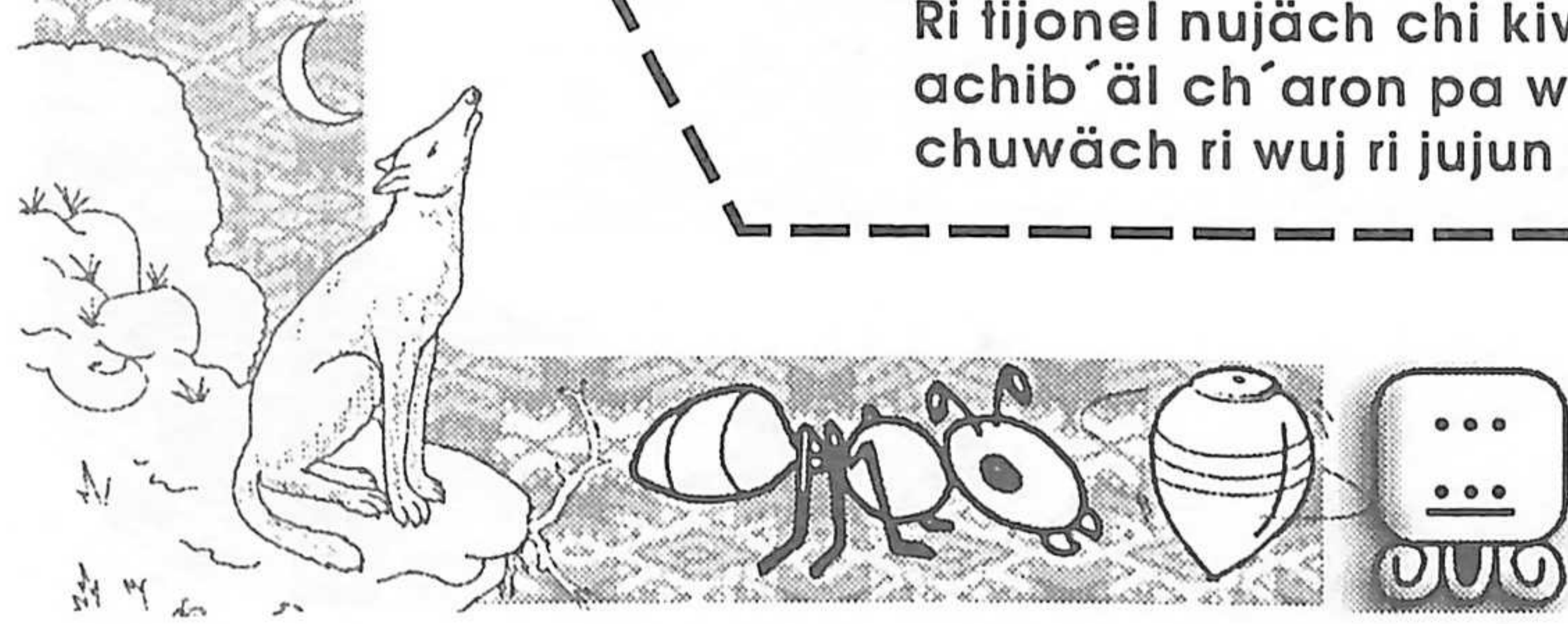

Tqach'ob'o' kik'in qate' qatata', kik'in qachib'il ri rusamaj nub'an ri rupam ri qach'akul

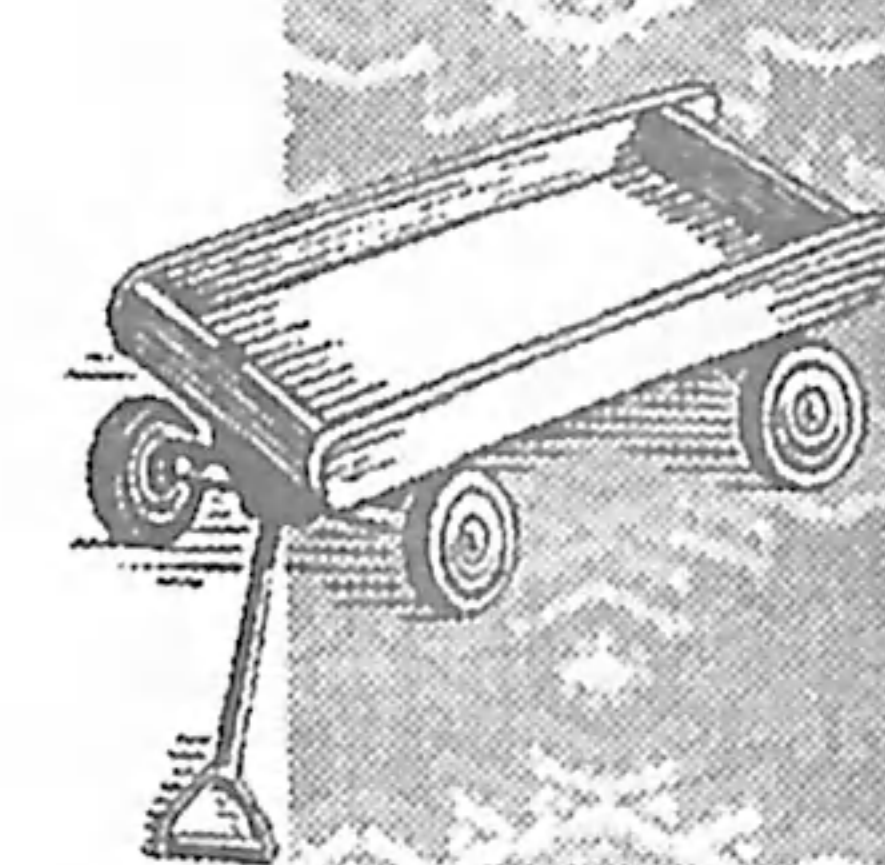
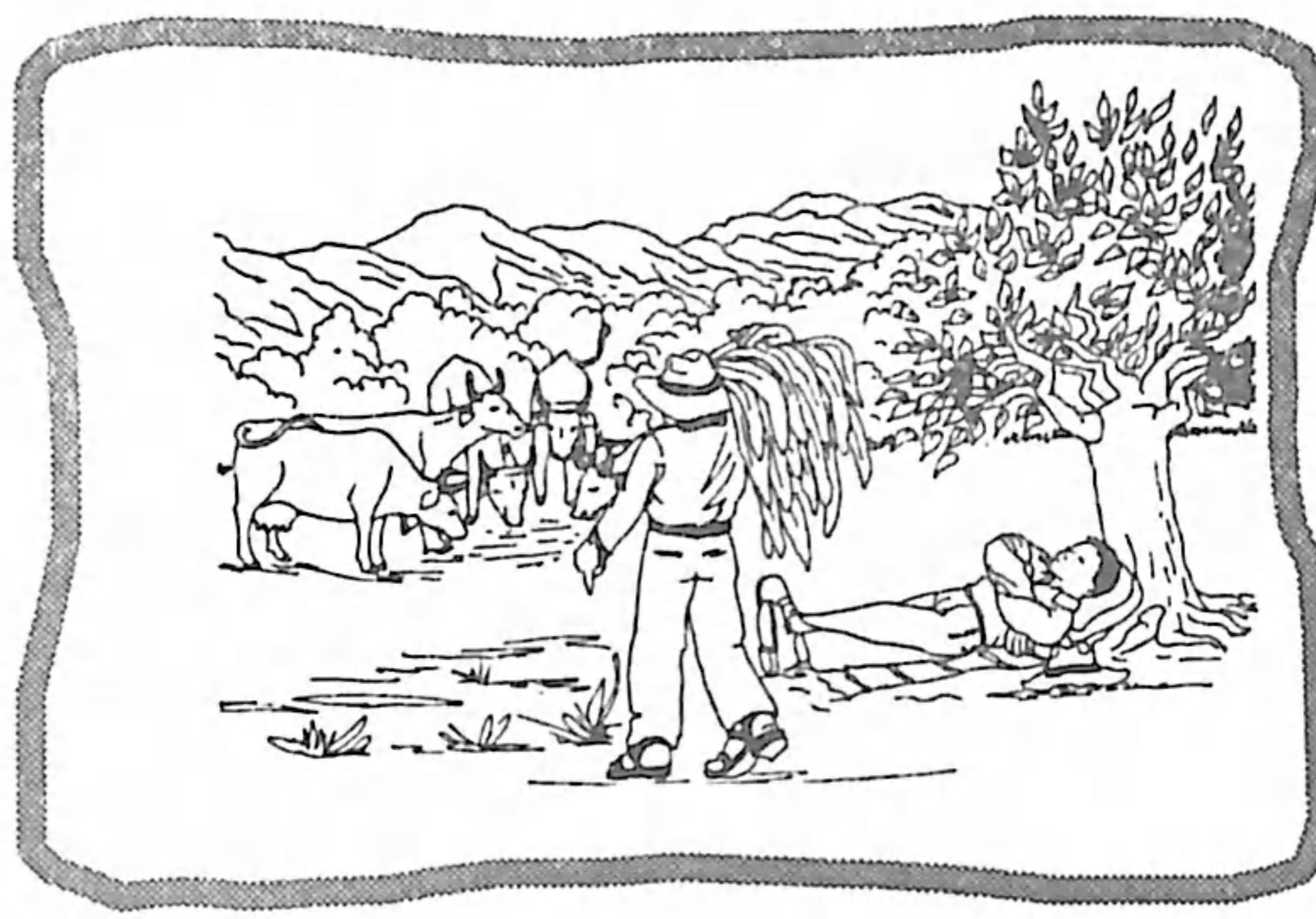
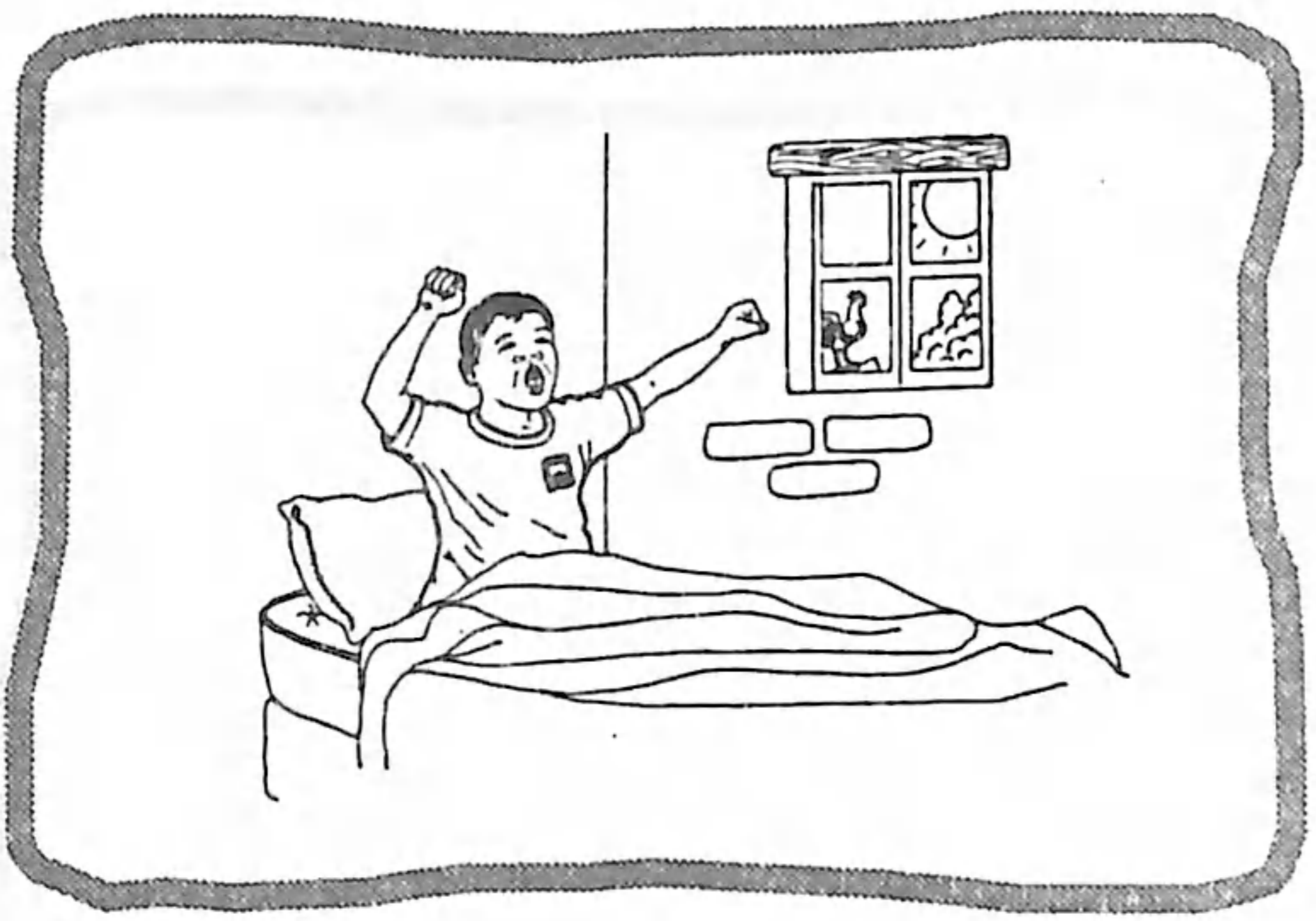
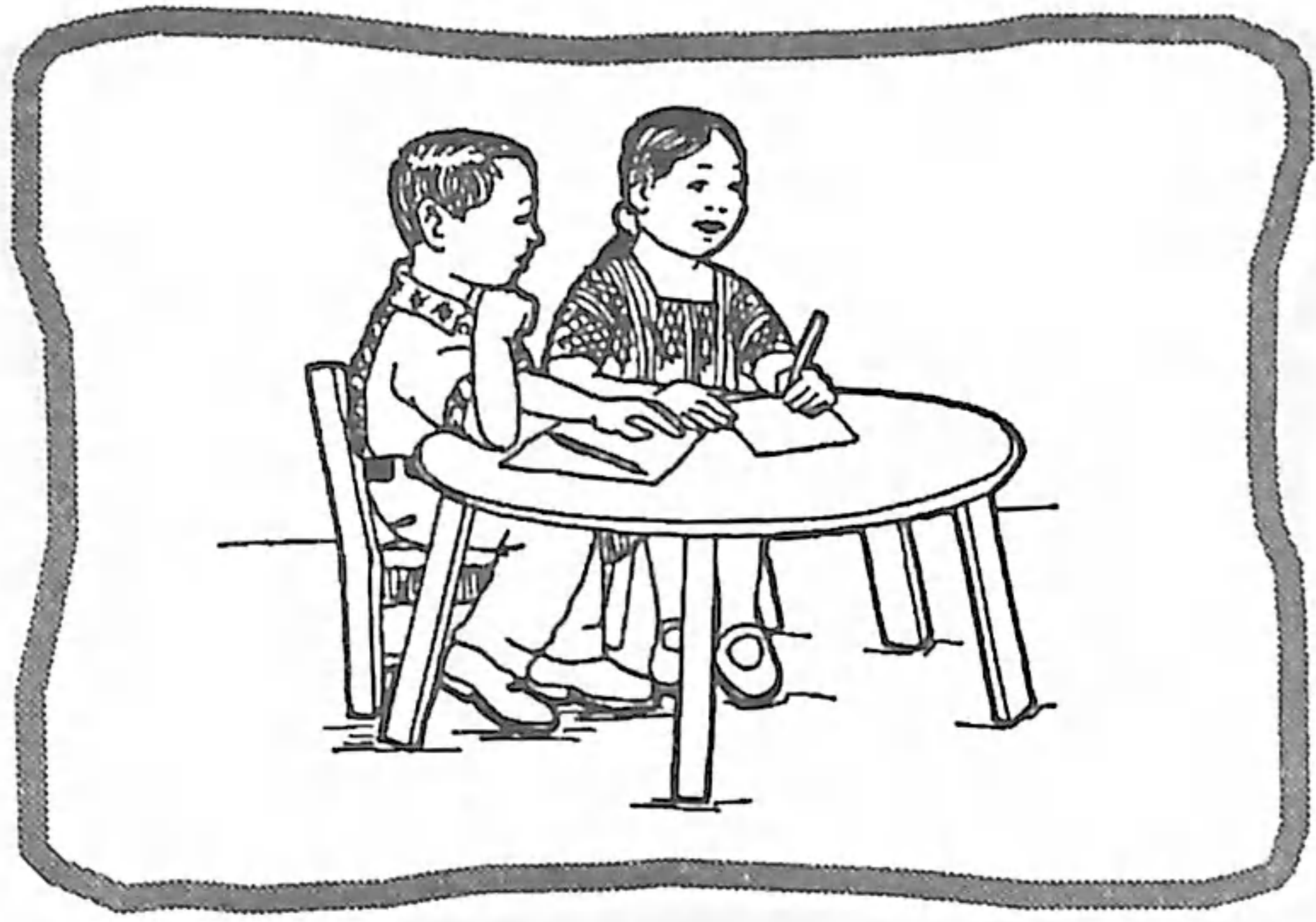

Ri tijoxela' nkitz'ib'aj pe pa ruwi' jujun kajtz'uk ri xkich'ob' kik'in kite' kitata', pa ruwi' ri nk'atzin jujun rupam ch'akulaj.

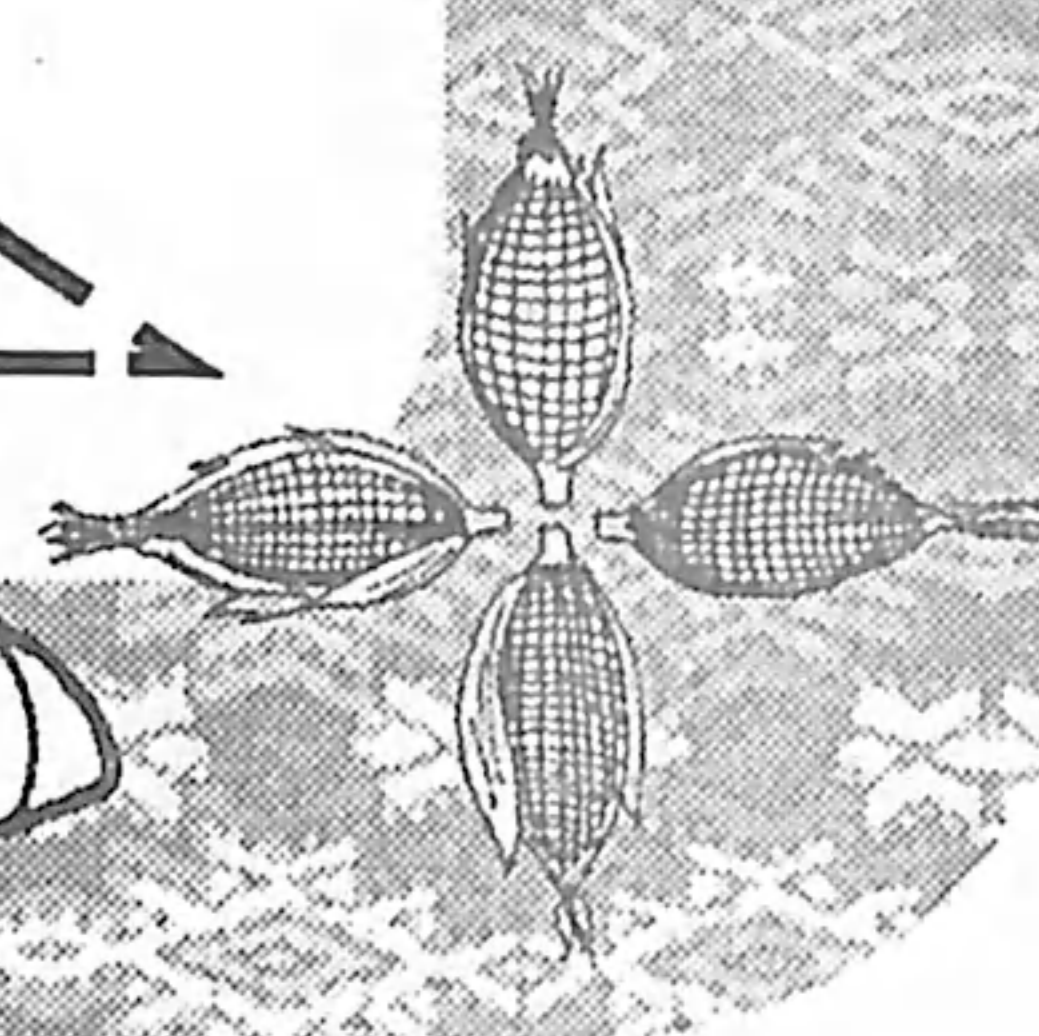
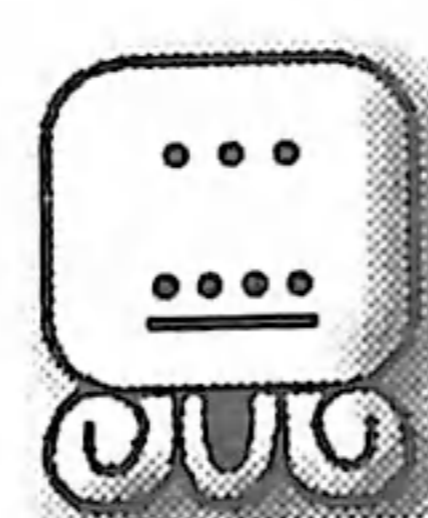

# Tqetamaj ruk'ojlemal ri qach'akul



Ri Nwetamaj

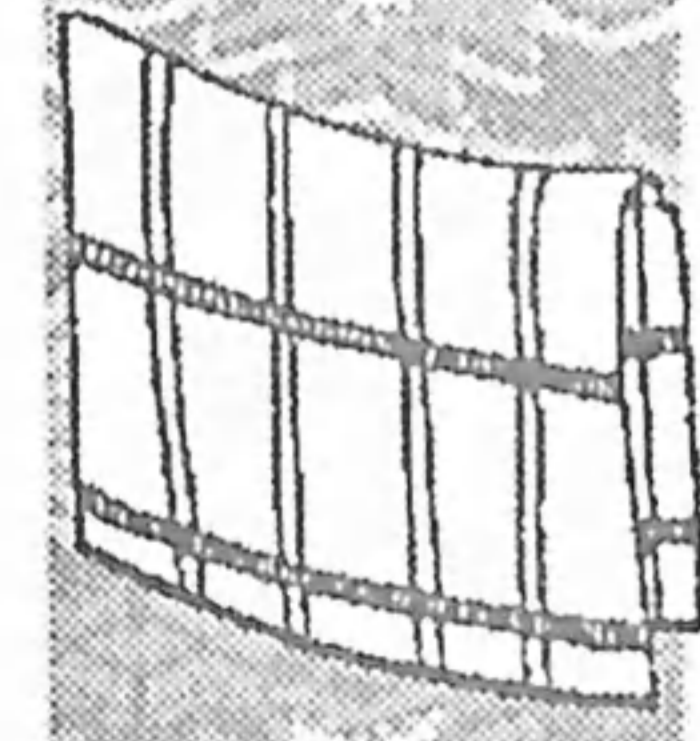
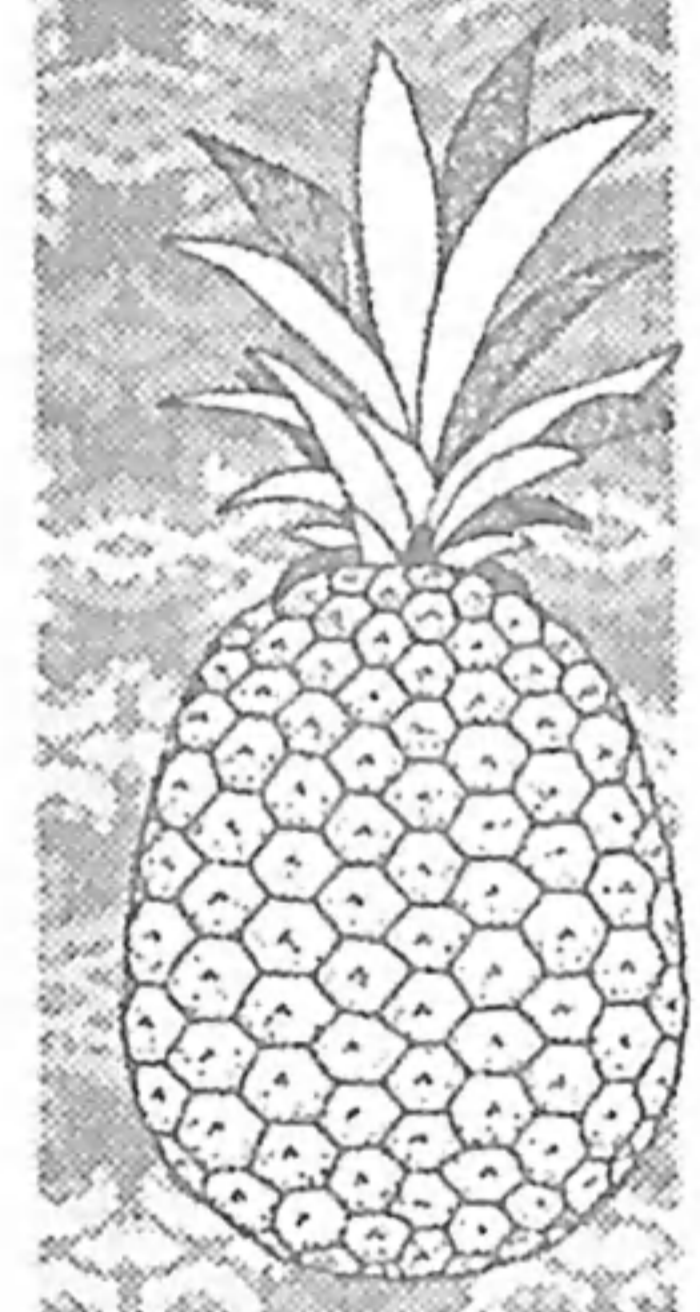

Pa'al ri ak'wal



Chakal qa ri ixtan



E xukul ri winaqi'

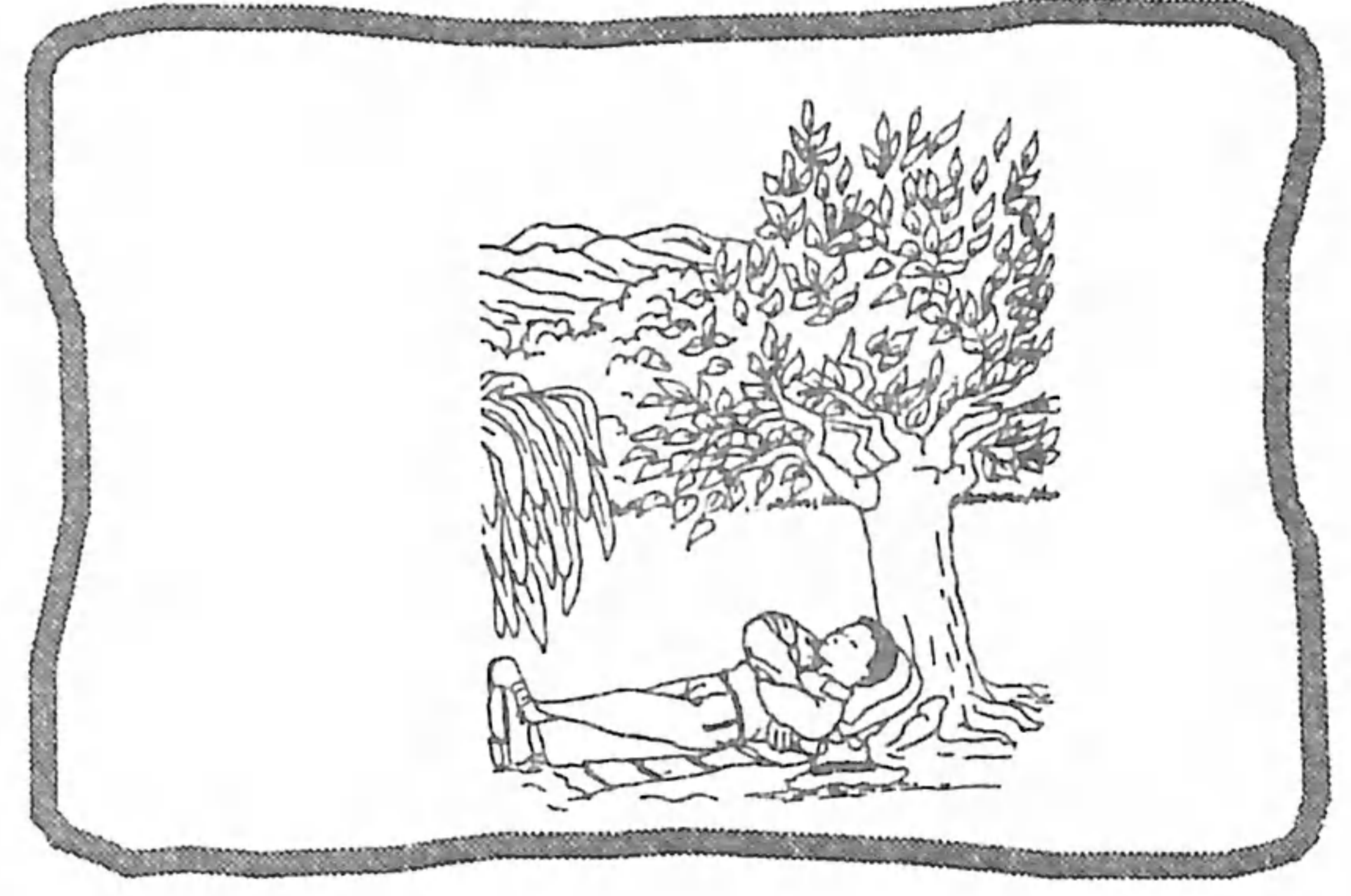

kotzol ri achin chuxe' ri che'

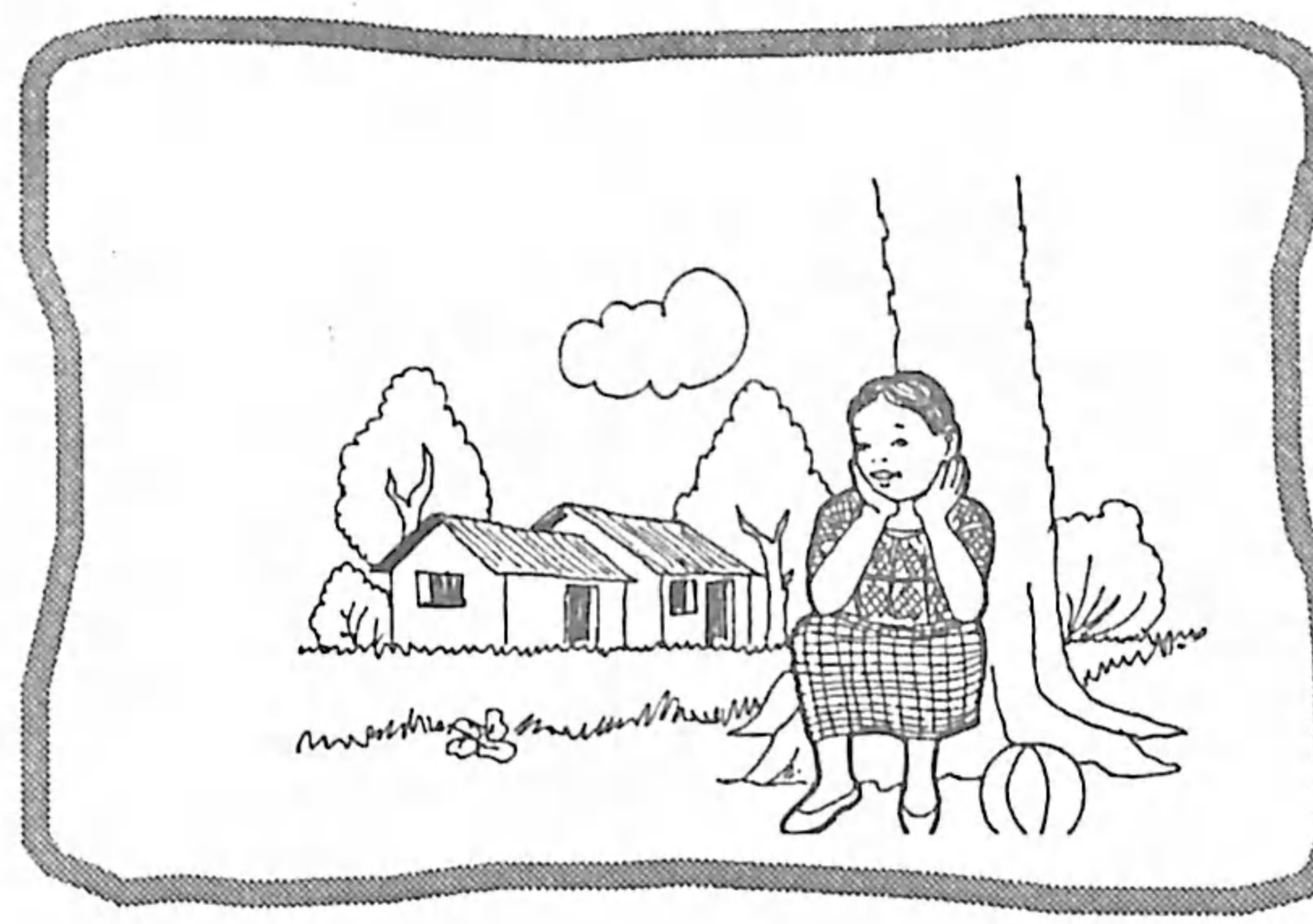

Tz'uyul ri ixtan chuxe' ri che'

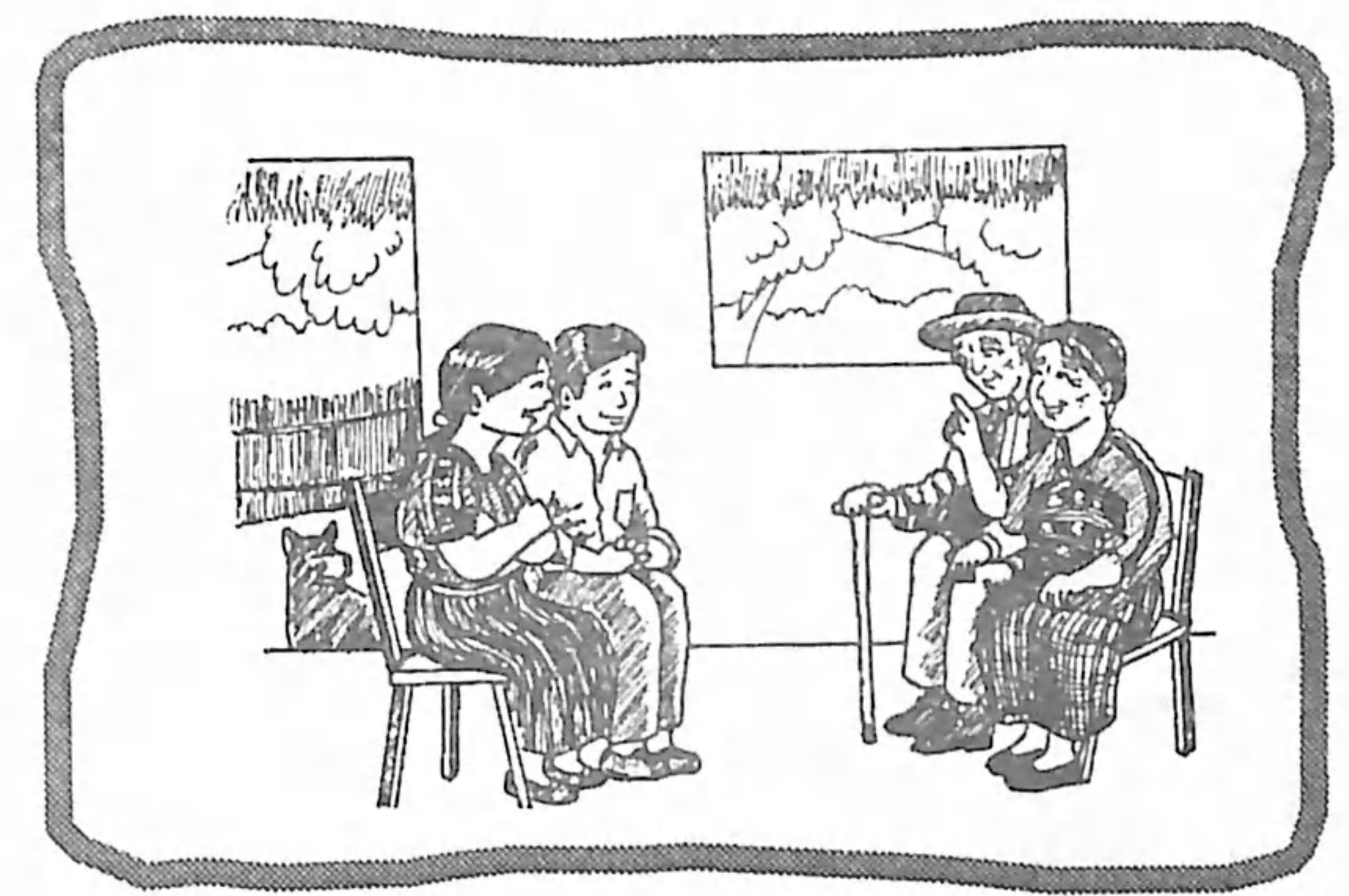

E tz'uyul ri winaqi'

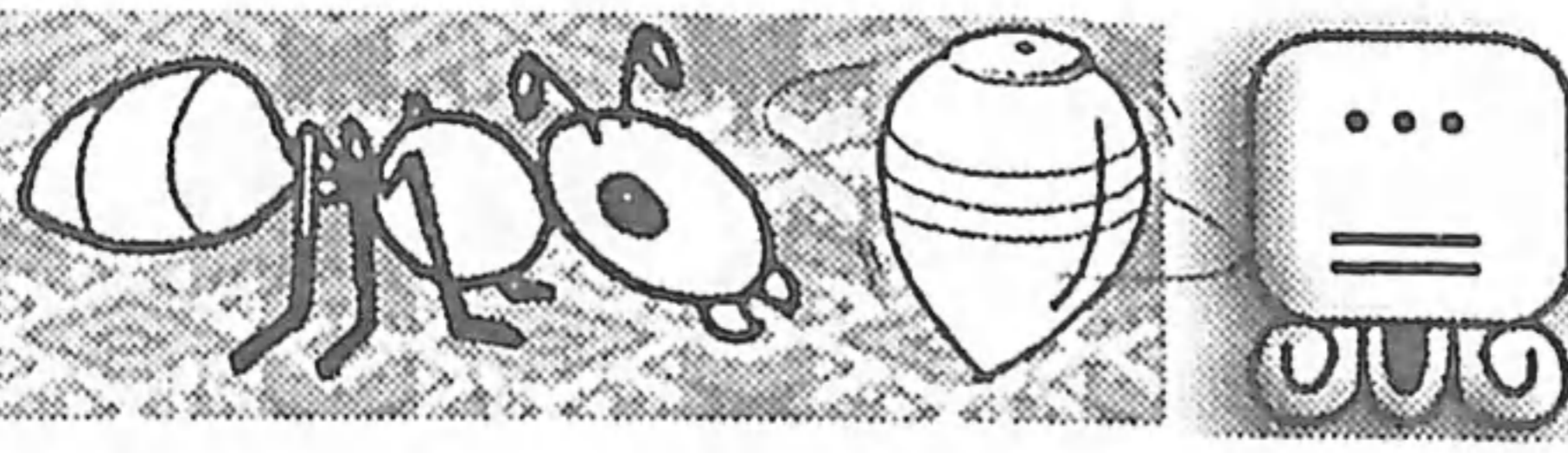

# Kojtzijon

Tqasiloj qaq'a'  
 Tqasiloj qaqän  
 Tqasiloj qajolom  
 Kojropin  
 Kojluke'  
 Kojtz'uye'  
 Kojxuke'

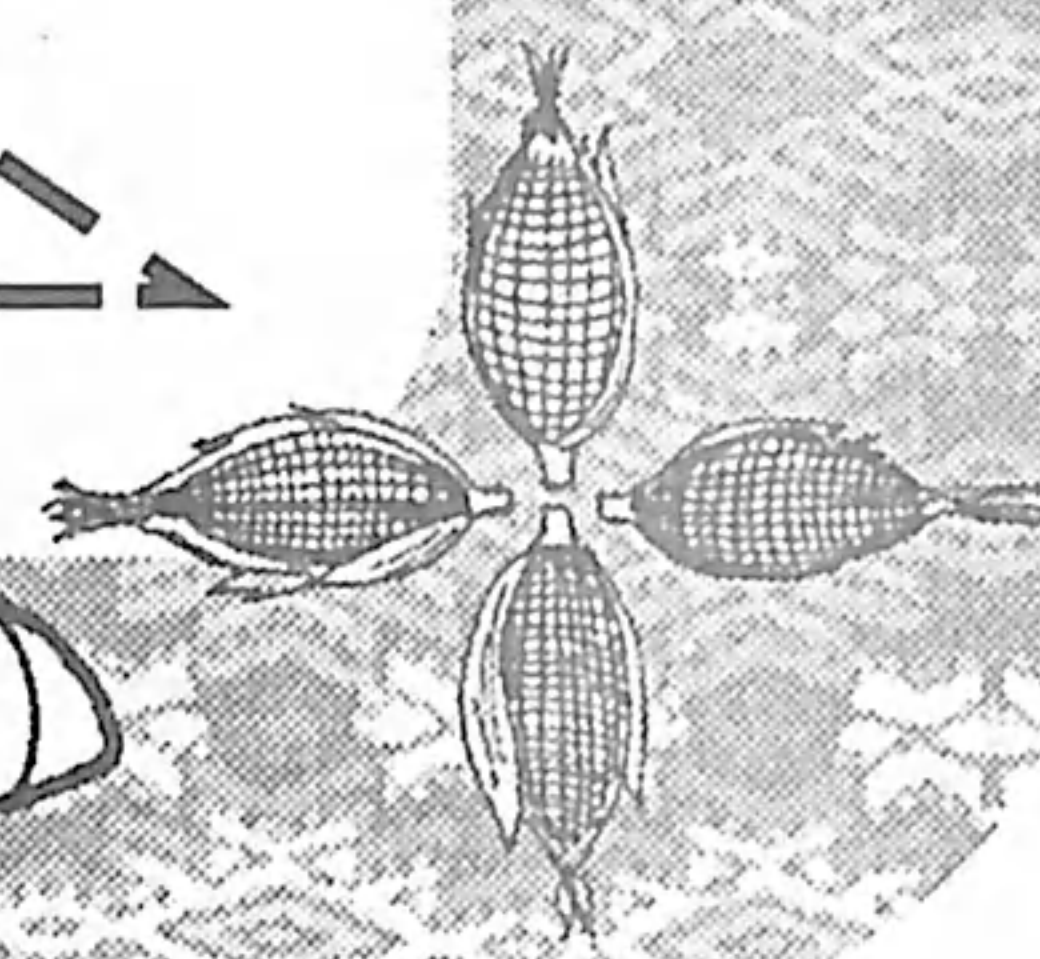
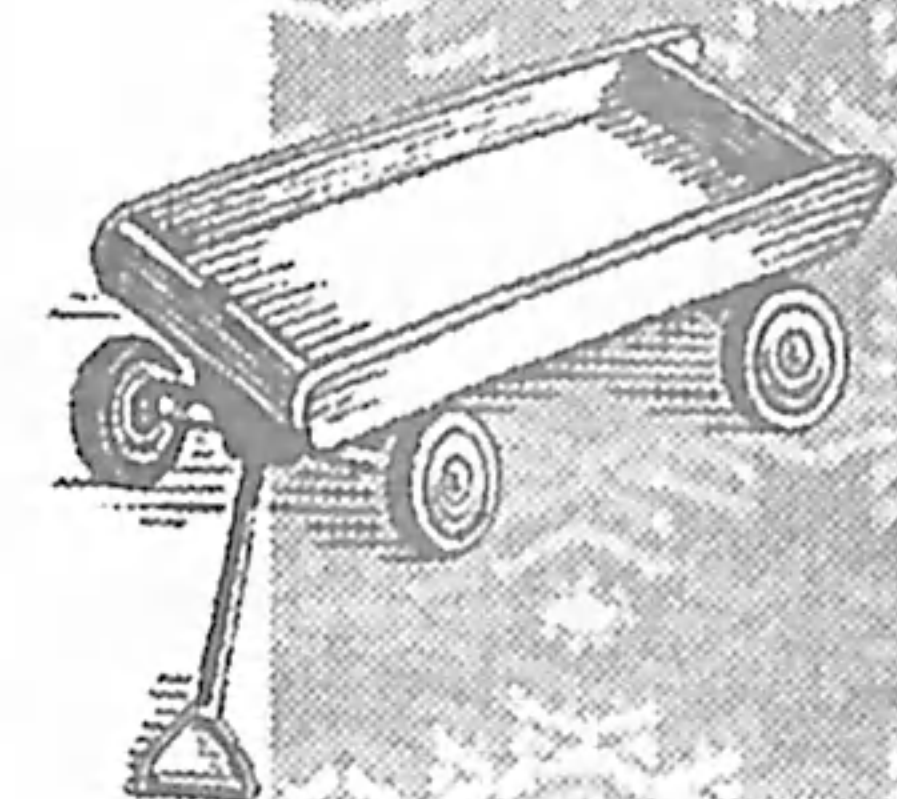

# Kojsamäj qonojel: Tqab'ana' jun etz'anem:

Nqab'än ri etz'anem.  
 Tkik'utu' ri kijolom  
 Tkik'utu' ri kiqul  
 Tkik'utu' ri ruwi' kitele'm  
 Tkik'utu' ri kitz'ik.  
 Tkik'utu' ri kich'ek

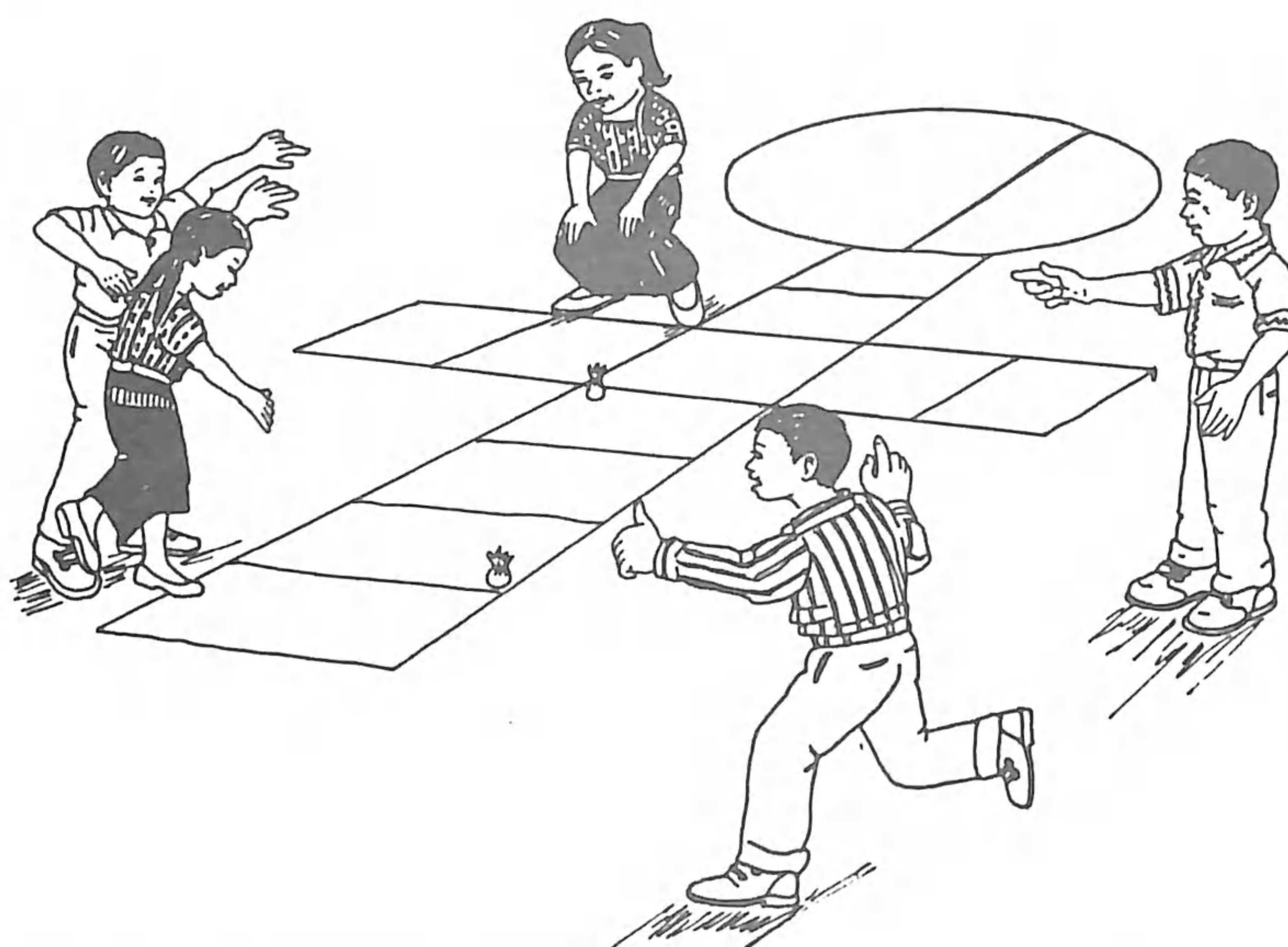

Kojetz'an qonojel: Tqab'ana' jun etz'anem chuwajay: Ri tijonel yerucholajij ri ak'wala'richin nkib'än ri etz'anem.





# Kojtzijon pa ruwi' ri rupam qach'akul



Ixchel: Achike natz'ët chuwäch  
re jun achib'äl re':

Saqche': Rïn yenutz'ët ak'wala'  
ye'etz'an pa ulew  
rik'in taq ch'ich'.



Ixchel: Achike ruk'oxomal nkib'än  
re wachinäq re natz'ët chuwäch  
re jun achib'äl re':

Saqche': Rïn ninwak'axaj jun tolon ch'ich'  
jun q'ojom, chuqa' jun xul.



Ixchel: Achike nana' rat Saqche'.

Saqche': Rïn ninna' jub'a' lilöj, ch'üch',  
meq'ën, b'uyül, köw



Ri tijonel nrokisaj jalajöj rupam ri qach'akul, k'atzinel chi nuk'waj  
jalajöj wachinäq richin nub'än re jun samaj re'.

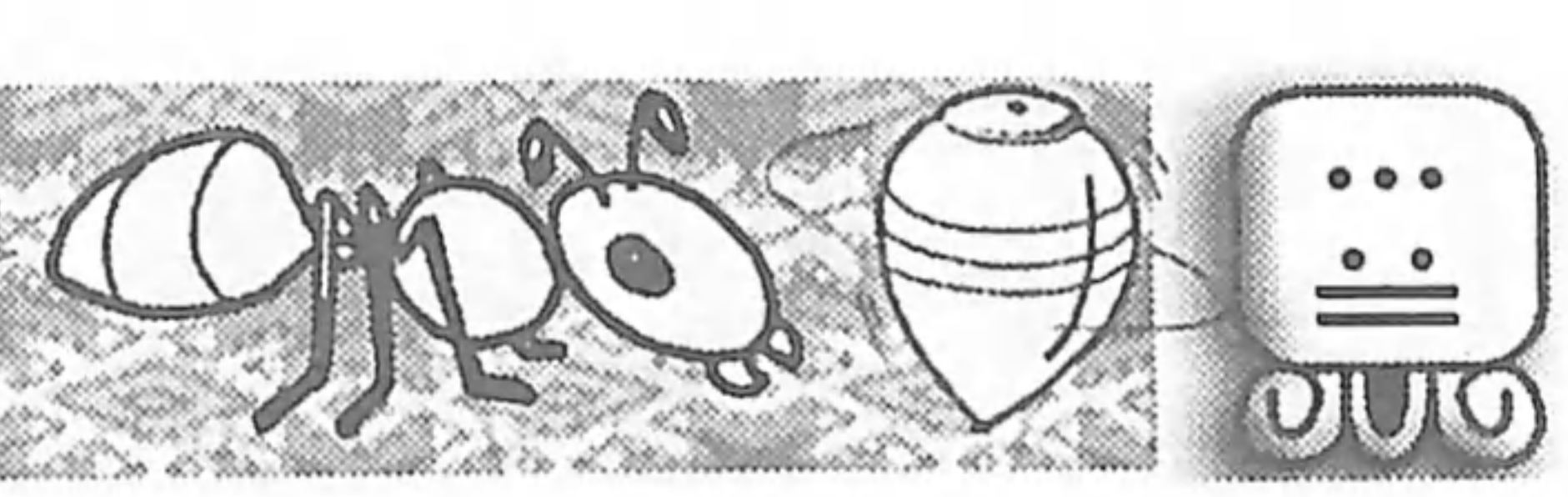
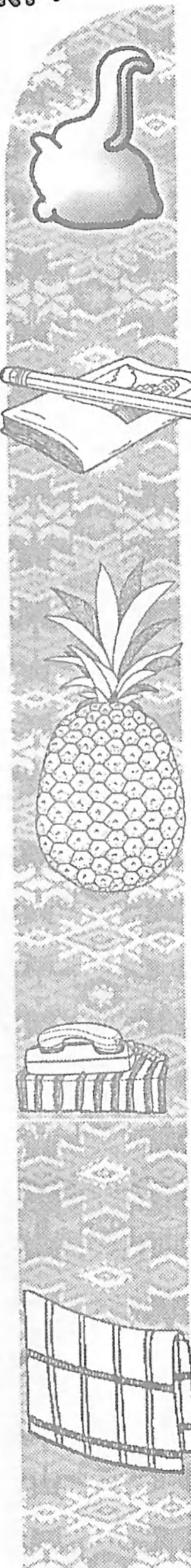

# Tqokisaj ri rupam qach'akul

Ixchel: Achike naseq  
rat Saqche'  
Saqche': Rin ninseq ruxula'  
jun alanx, anx, kotz'i'j,

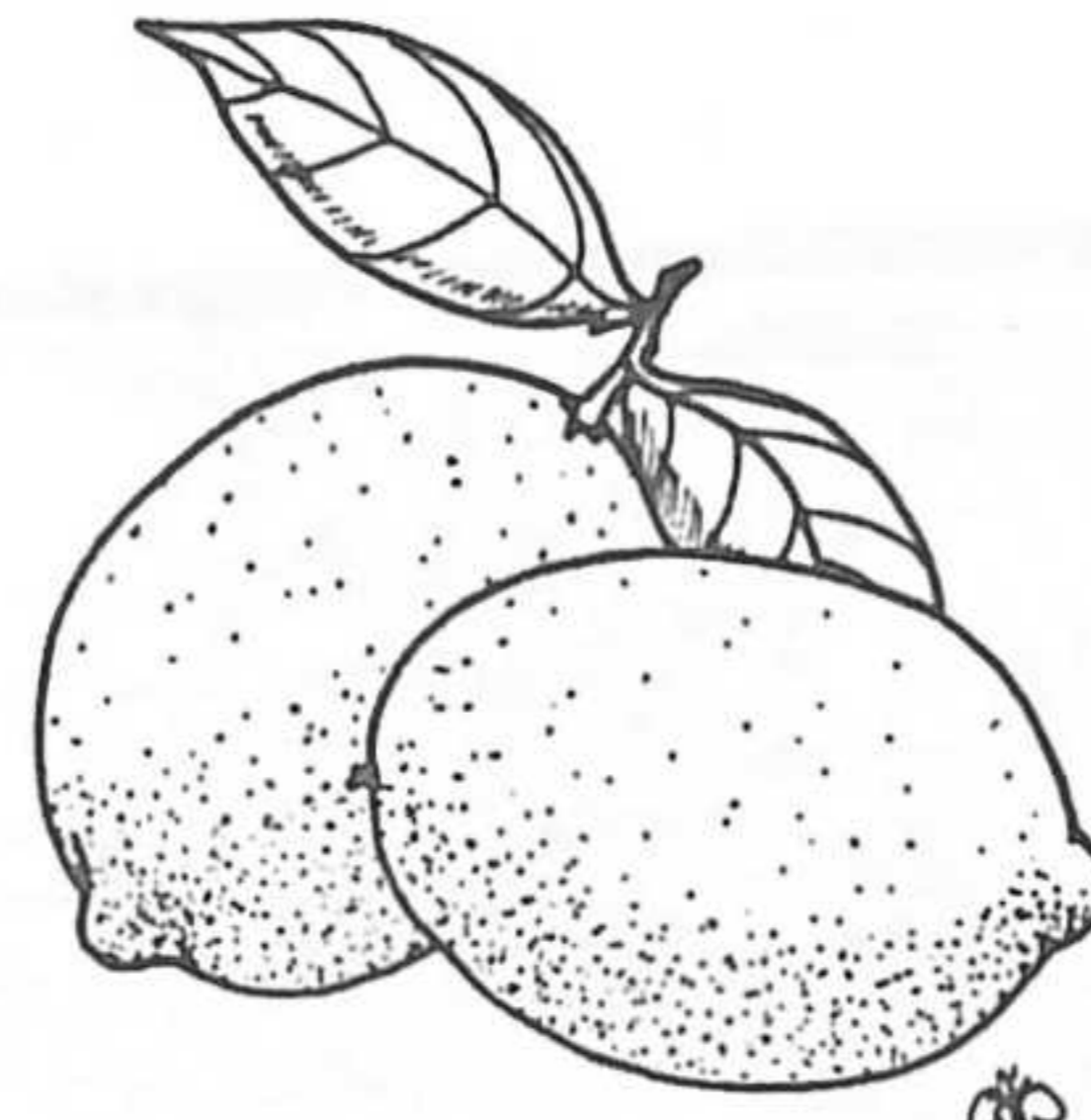

Ixchel: Achike ruki'il nana'  
rat ma Saqche'.  
Saqche: Rin ninna' jub'a'  
k'äy, ki', rar.



## Tqatz' aqatisaj ri k'utunik.

Achike rusamaj ri runaq' qawäch

Achike rusamaj ri qaxikin?

Achike rusamaj ri qatza'm?

Achike rusamaj ri qachi'?

Achike rusamaj ri qaq'?

Janipe' qey e k'o pa qachi'

---



---



---



---



---



---

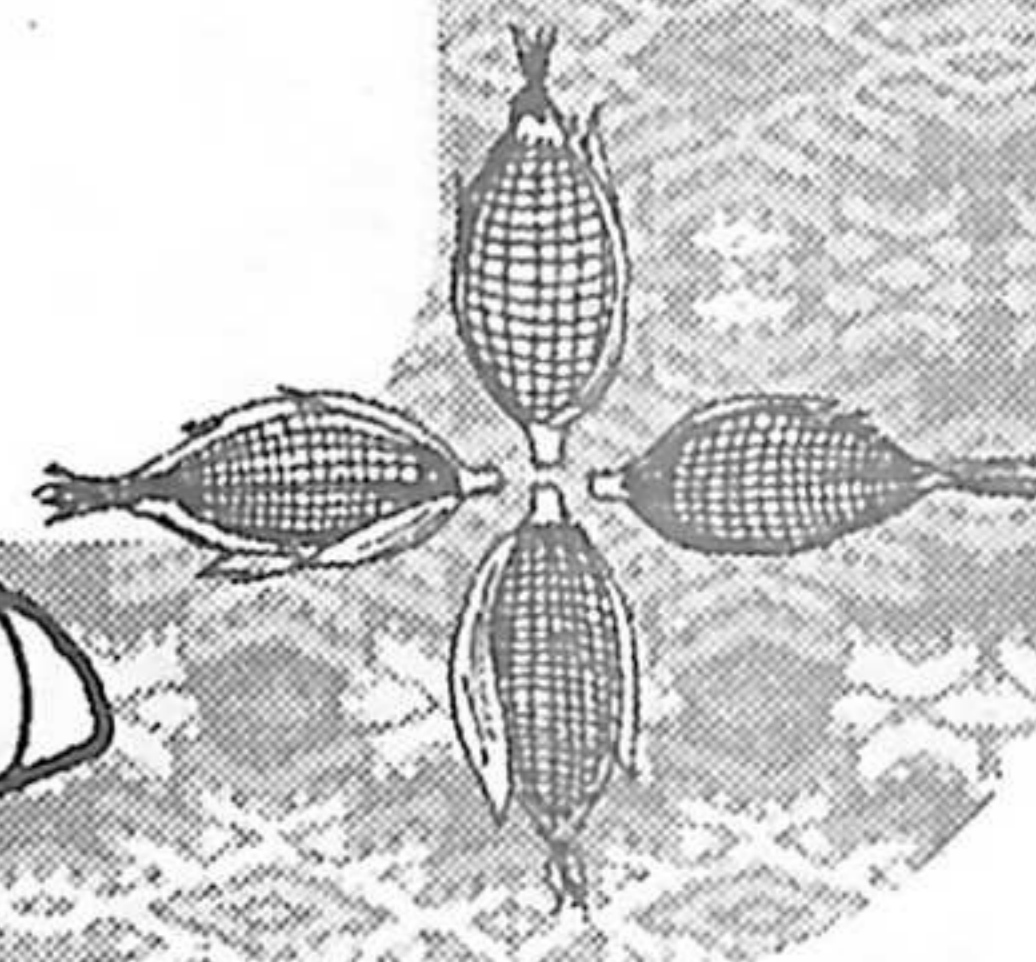



Ri Nwetamaj

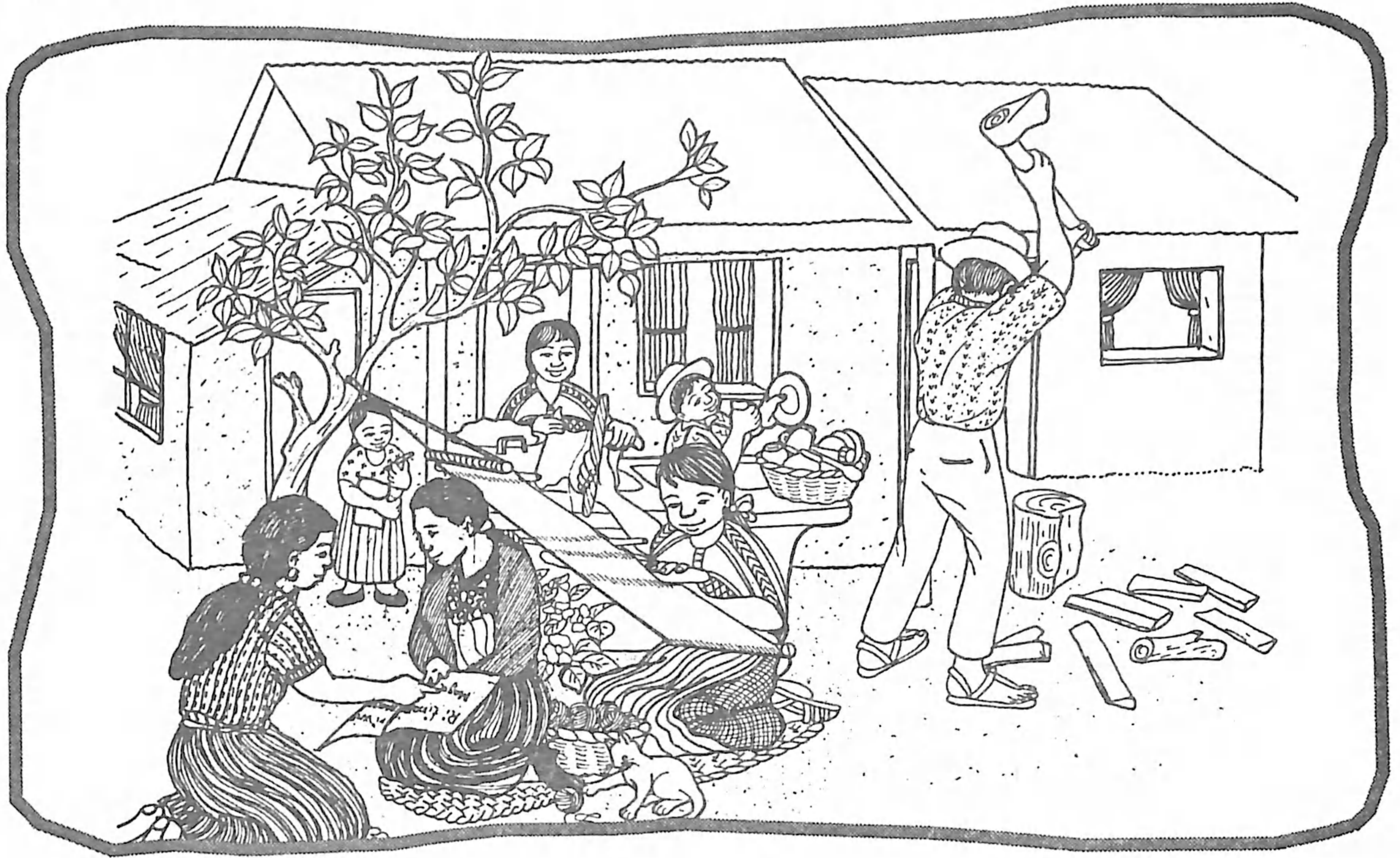

Achike kib'anon re winaqi' e k'o chupam re jun achib'äl re':

---



---

Ütz nqatijoj qi'.

Ixchel

- Katpa'e'
- Kattz'uye'
- Katxuke'
- Katk'awe
- Katraq'e'

Saqche'

- katjupe'
- kotkotch'e'
- Katwuqe'
- katluke'
- Katk'awe'

Ri tijoxela' k'o chi nkib'ij achike kik'ojlemal kib'anon ri winaqi', chuqa' yetzizon pa kaka' richin nkib'än ri jalajöj k'ojlemal.

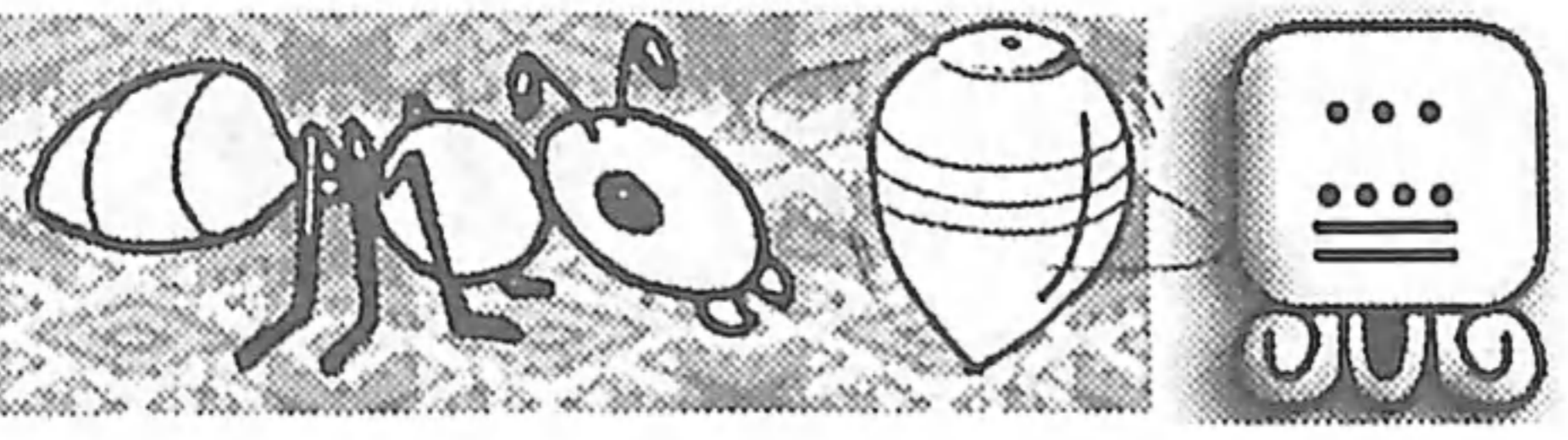

Achike kik'ojlemal ri chikopi'  
Tqatz'aqatisaj ri k'utunik.



Sotöl ri kumätz pa q'ayis      Chakäl ri tukür pa ruwi' che



Pa'äl ri tz'i' pa ulew      E chakäl ri tz'ikina'

Achike kik'ojlemal ri wachinäq  
Tqatz'aqatisaj ri k'utunik.



E tik'il ri läq chuwäch ch'atal      E tzeqël ri wuj chuwäch xan

Ri tijonel tub'ana' ch'aa chik ruk'ojlemal ri ch'akulaj kik'in ri tijoxela'.

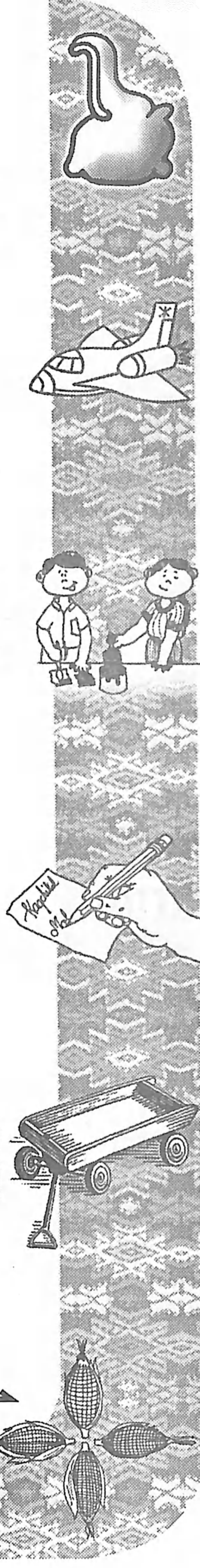



# Solojsamaj

Achike nuseq re jun ak'wal re'

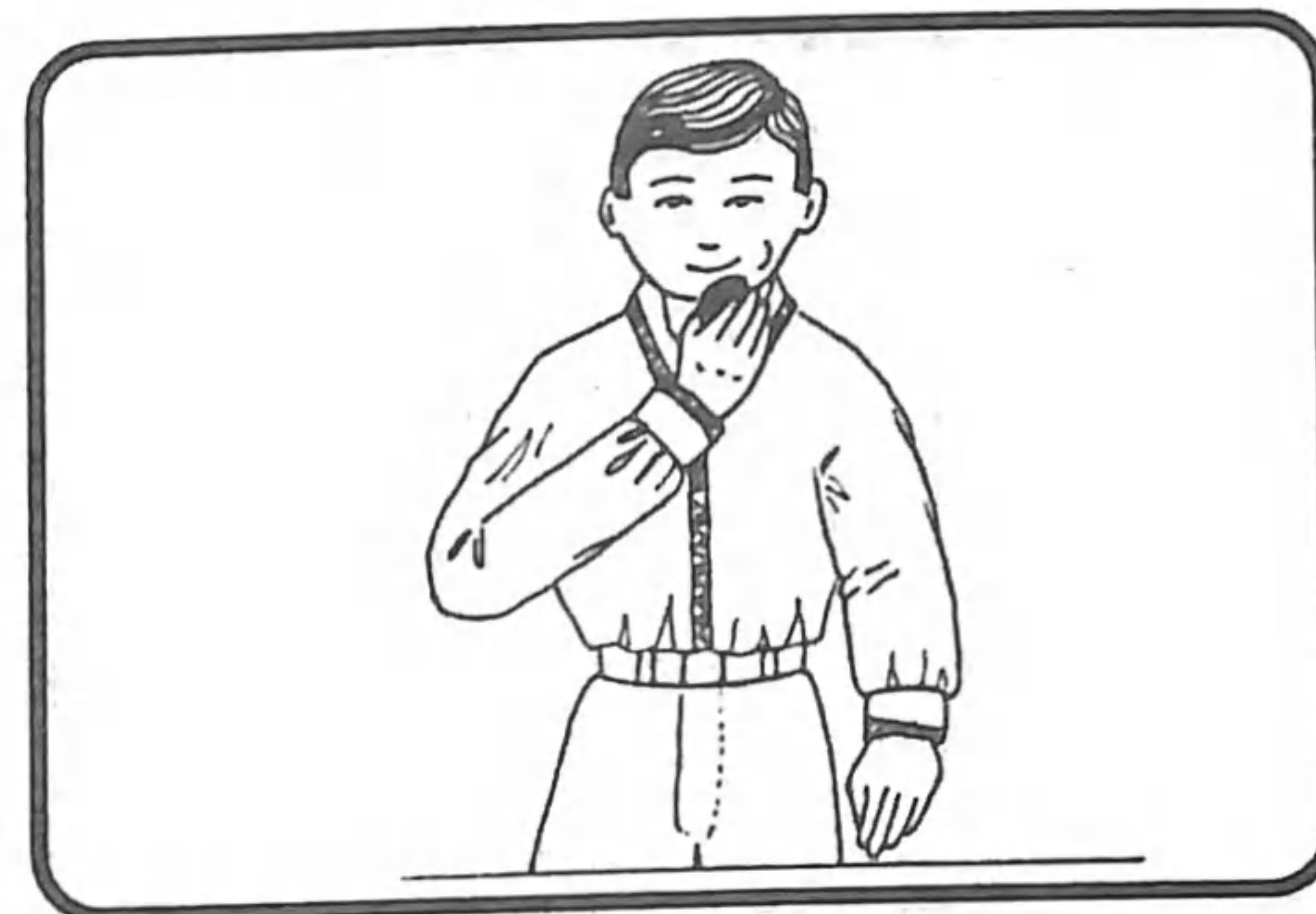

Achike nrak'axaj re jun ixtän re'



Achike nutij re jun ak'wal re':



Achike nuna' re jun ak'wal re':

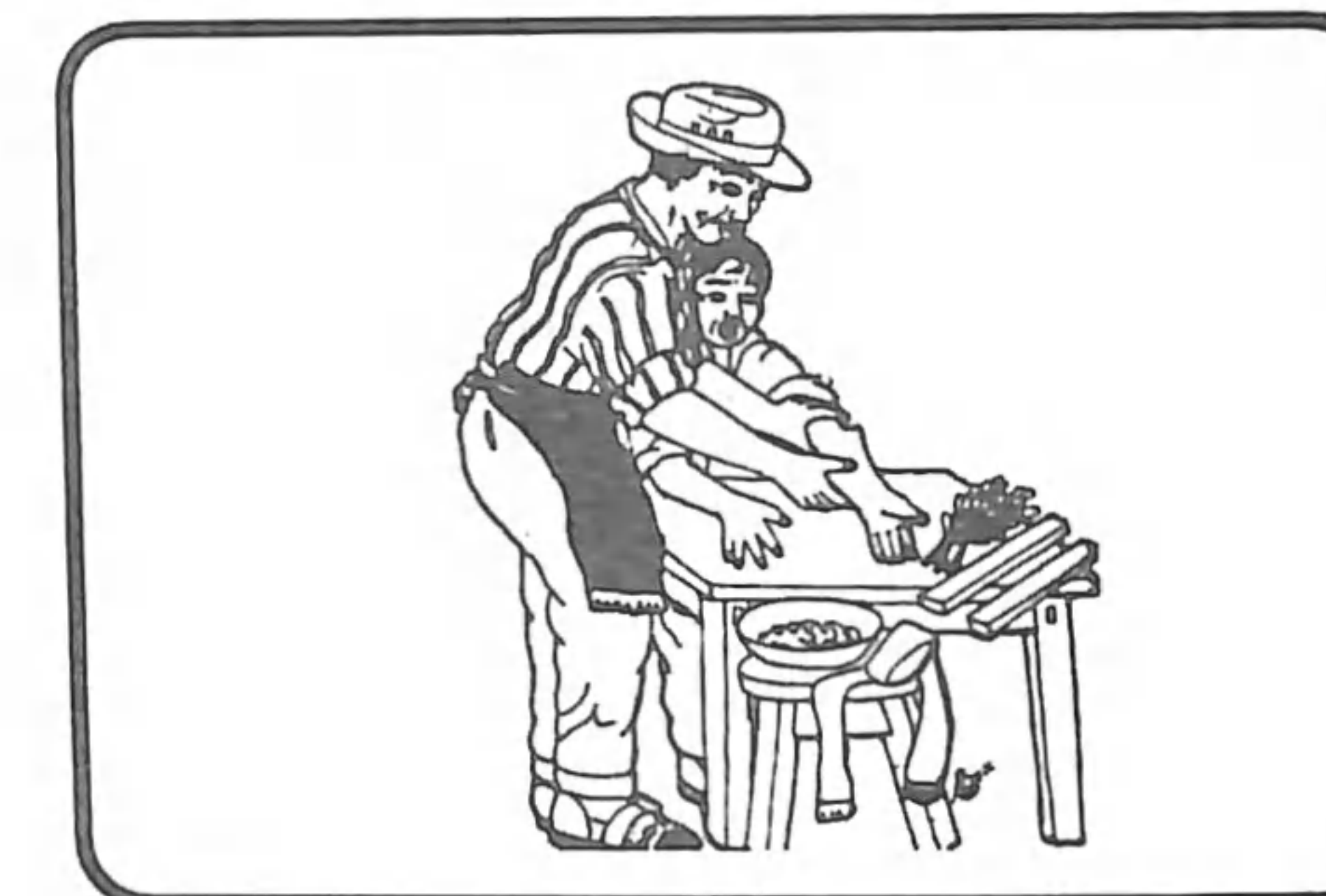

Ri tijoxela' nkib'ij pe achike nkitz'ët chupam ri achib'äl.



# Chupam re jun achib'äl re' tqaya' kib'i' ri rupam jujun ch'akulal

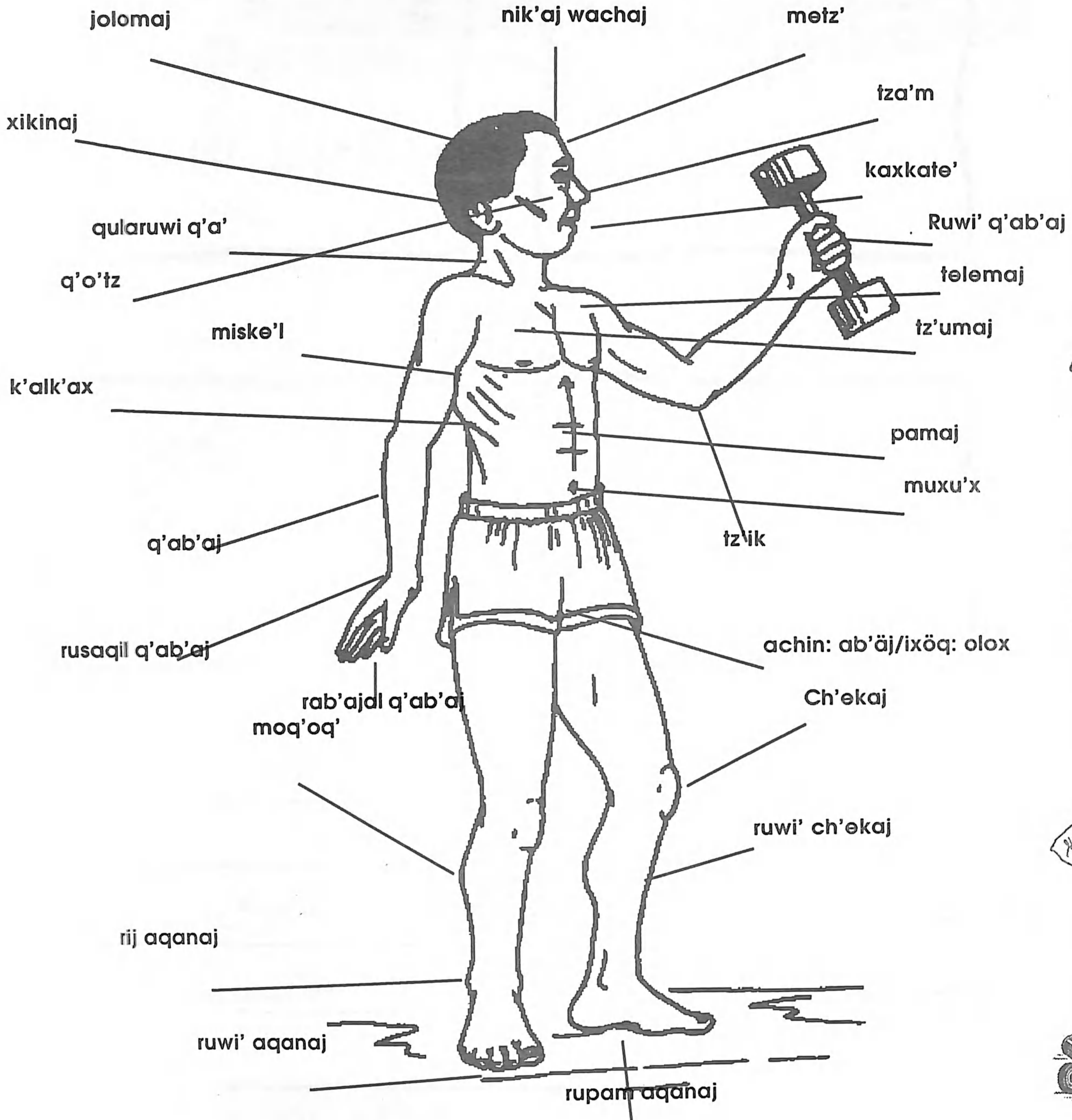

Ri tijoxela' nkiya' rub'i' ri rupam ri qach'akul, chuqa' tikirel nkib'ij achike yek'atzin wi.

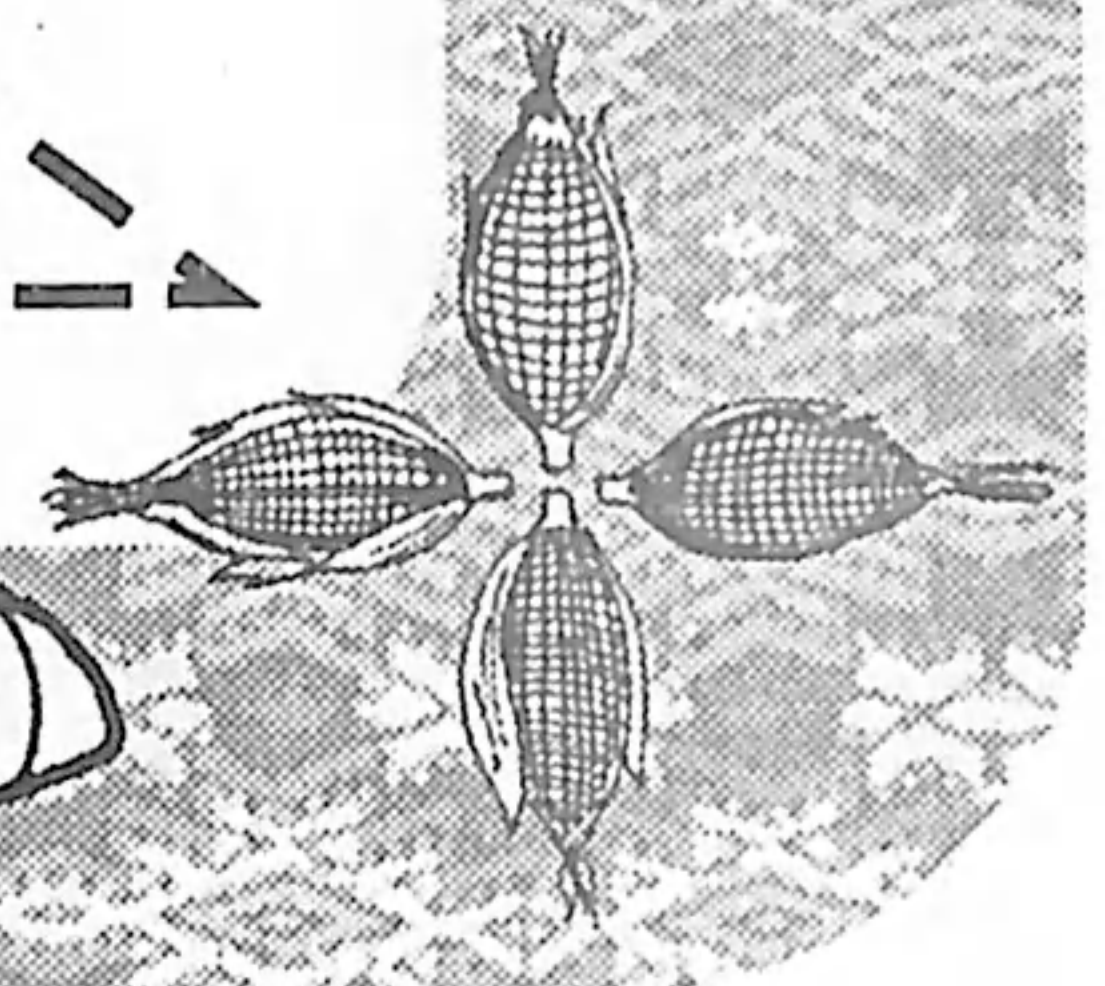



# Tojtoḅ'enik

## Achike kik'ojlemal re winaqi' re':

Ri Xinwetamal

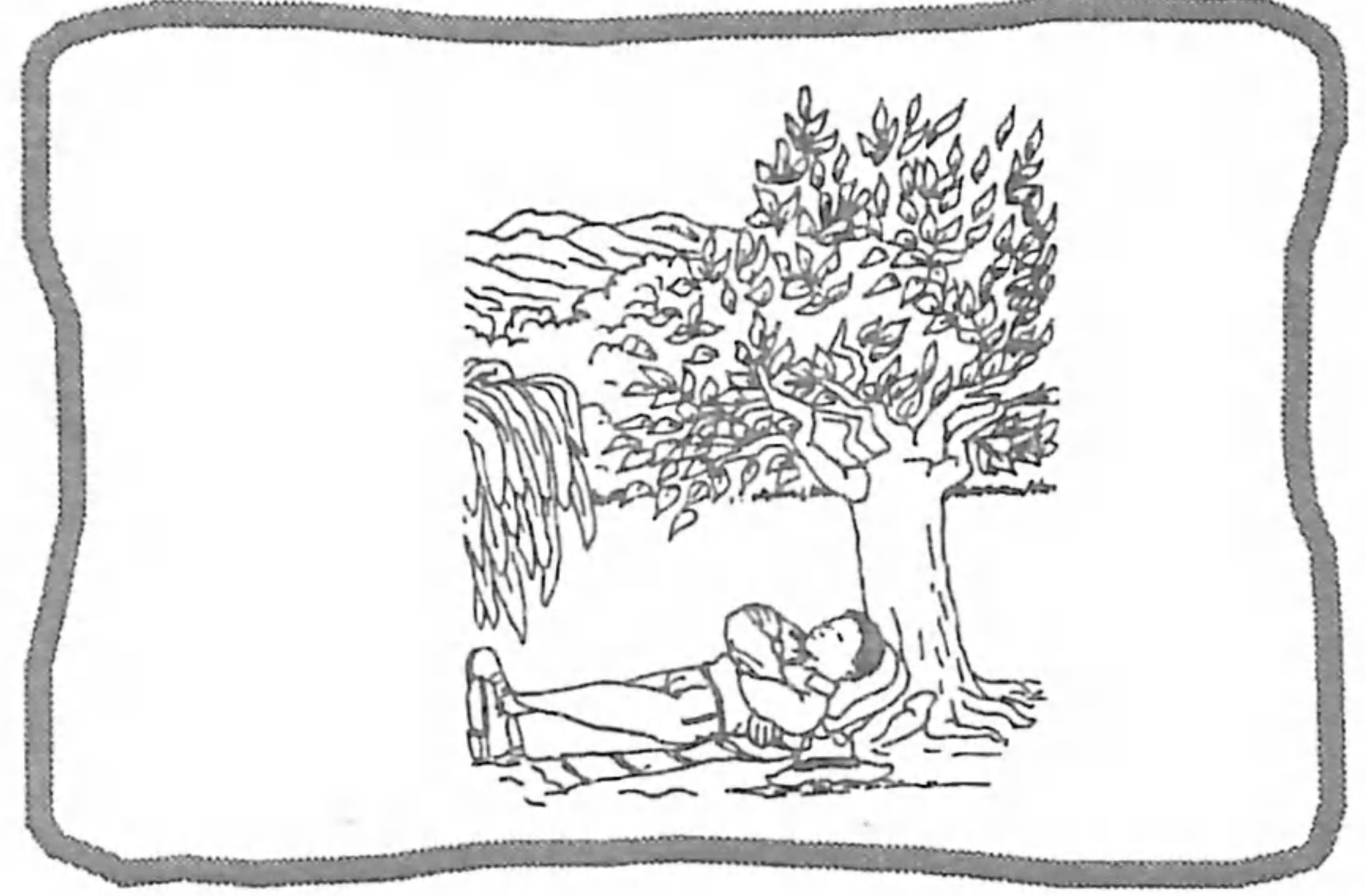
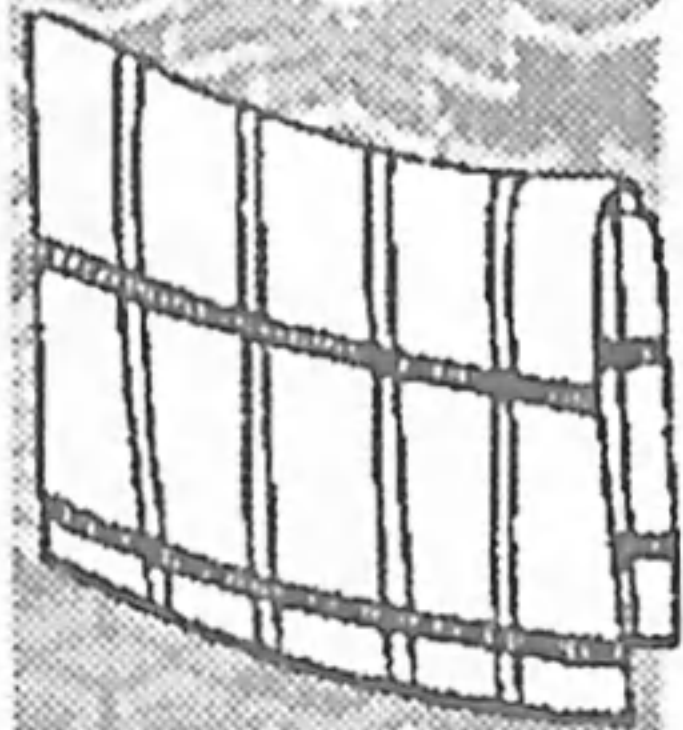
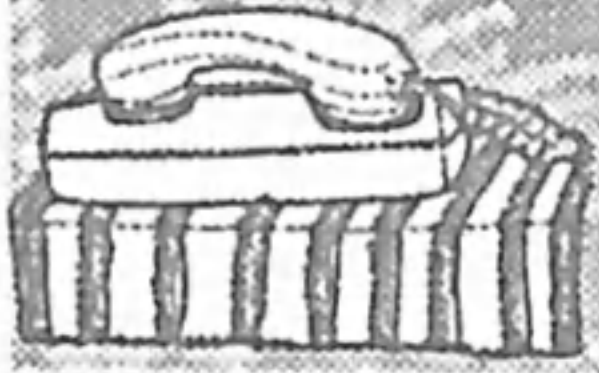
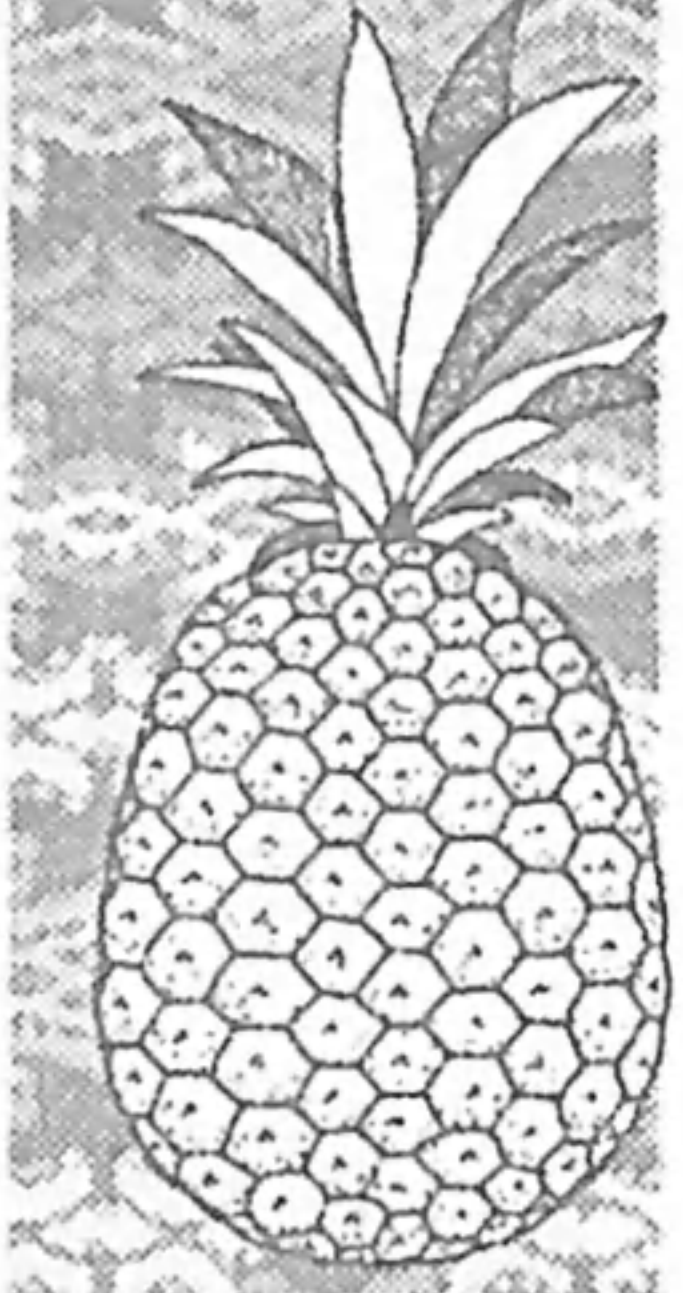
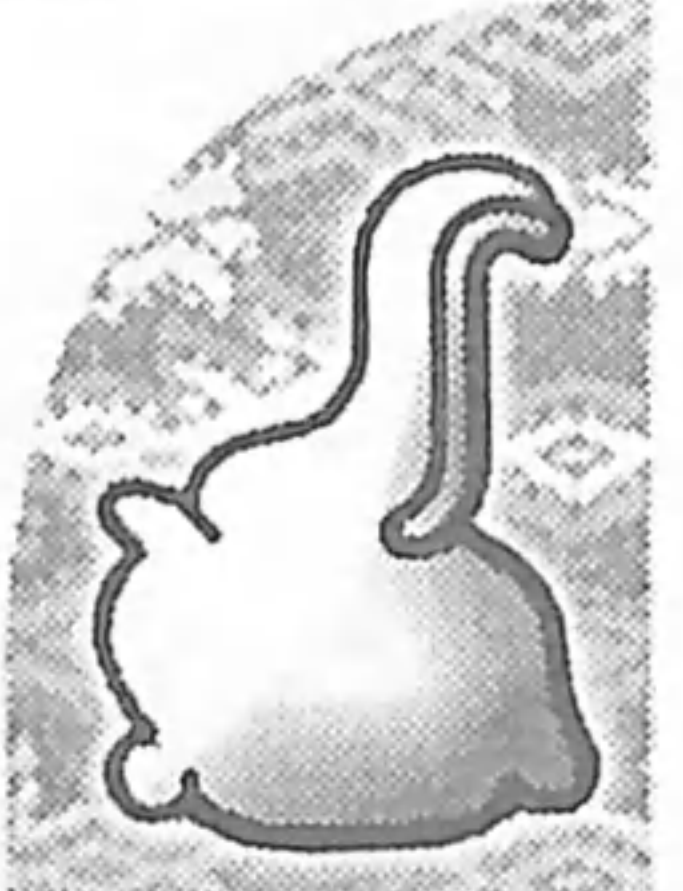

Achike rusamaj ri runaq' qawäch \_\_\_\_\_

Achike rusamaj ri qaxikin? \_\_\_\_\_

Achike rusamaj ri qatza'm? \_\_\_\_\_

Achike rusamaj ri qachi'? \_\_\_\_\_

Achike rusamaj ri qaq'? \_\_\_\_\_

Janipe' qey e k'o pa qachi' \_\_\_\_\_

Ri tijoxela' k'o chi nkitz'ib'aj pa taq juch' ri kik'ojlemal ri ch'akulaj, chuqa' ri nk'atzin wi.



# RUWUQ TANAJ

## Jalajöj ruwäch samaj

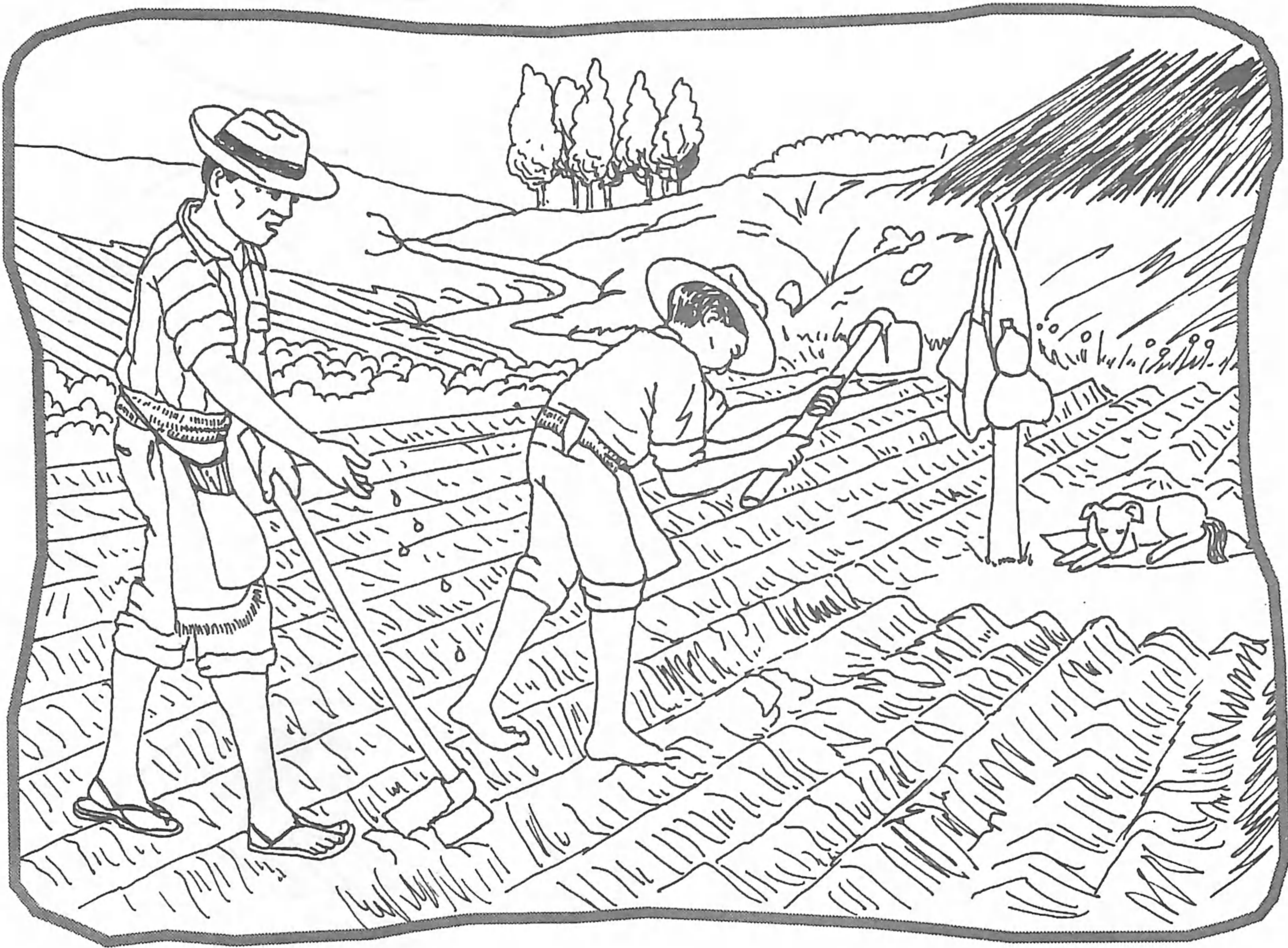

### Ri etamanik nuq'i' ri tijoxel:

Retaman ri jalajöj ruwäch b'anoj  
Retaman ri jalajöj winaqilal ri ye'okisäx.  
Retaman ri jalajöj samaj nkib'än pa qochoch chuqa'  
pa tinamit.

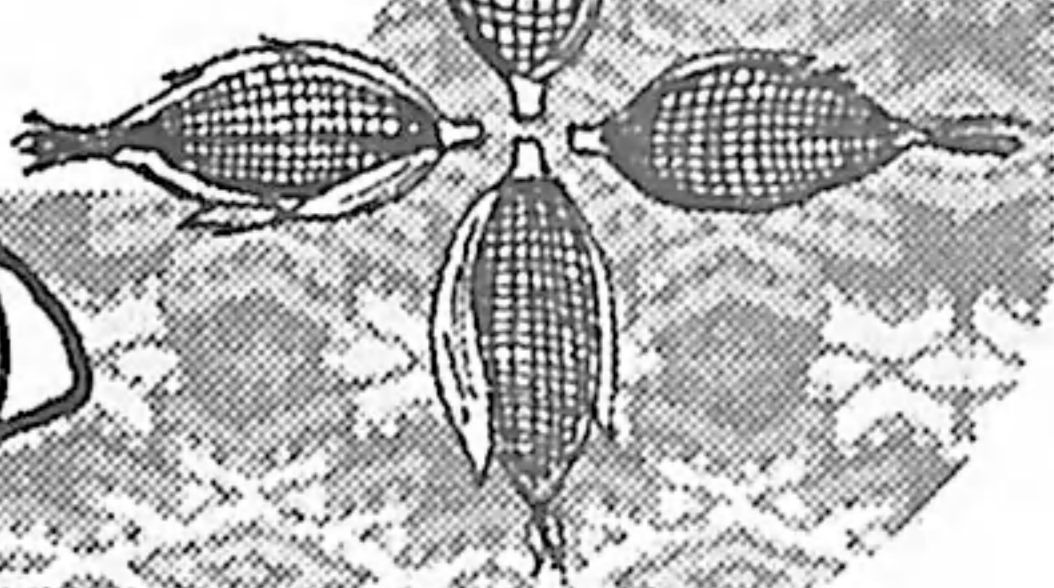
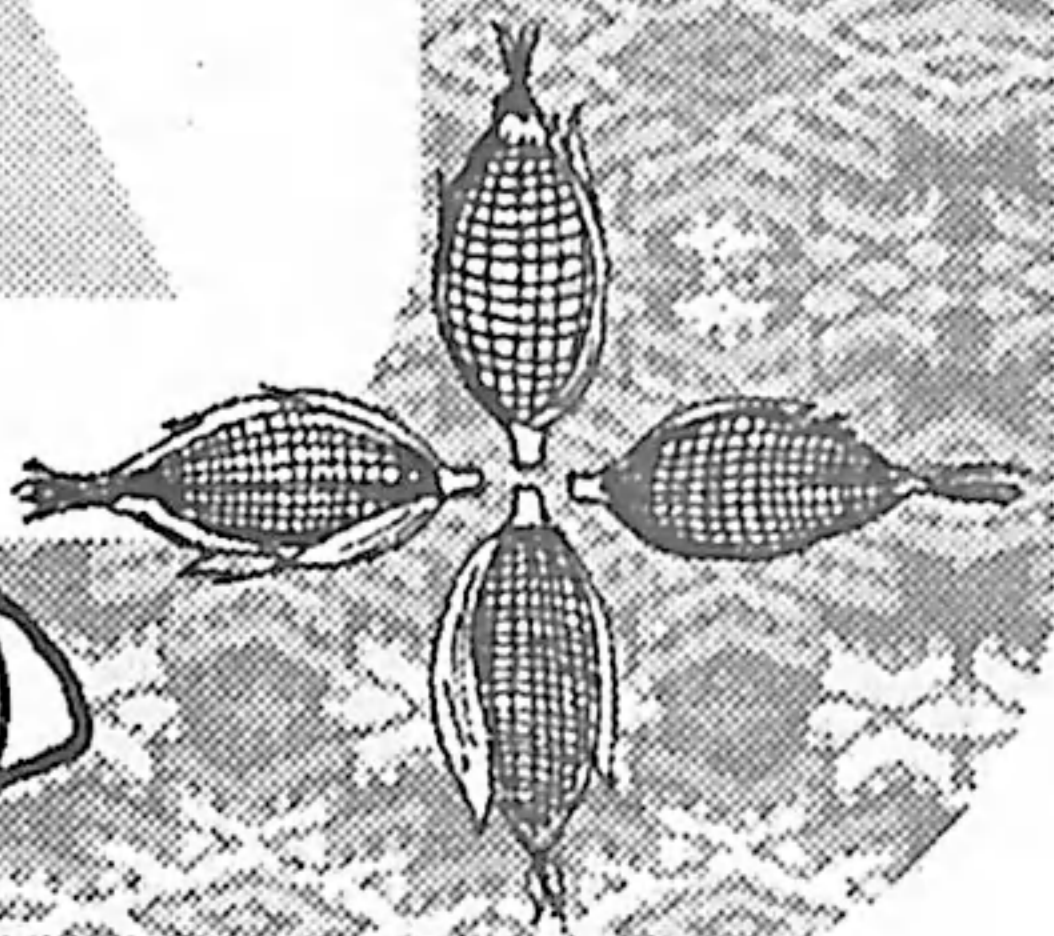
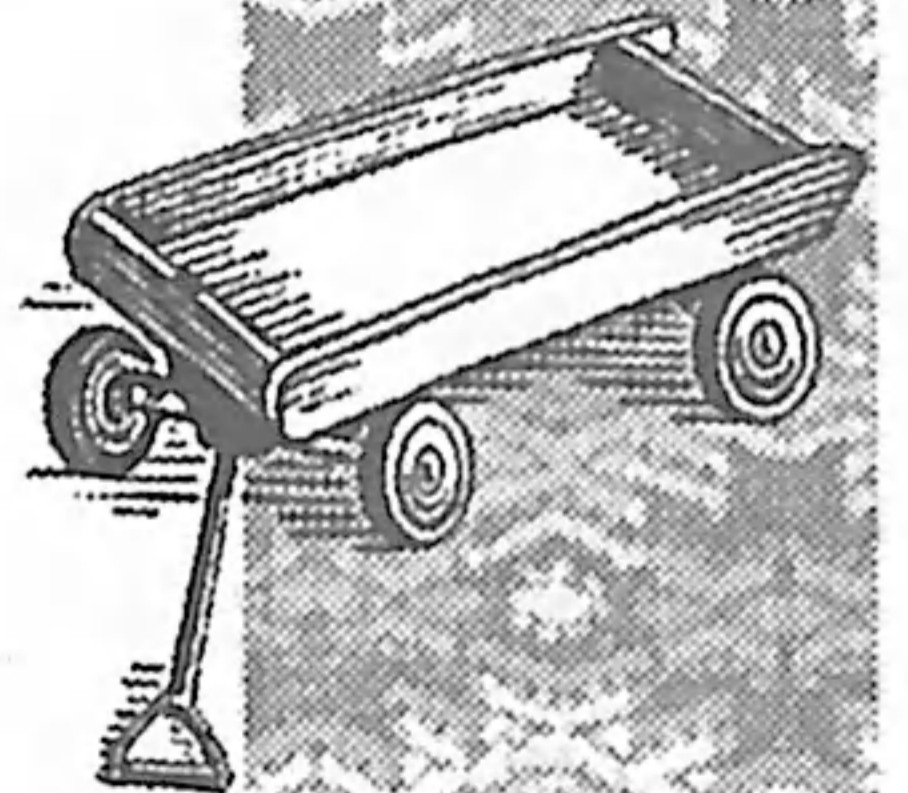
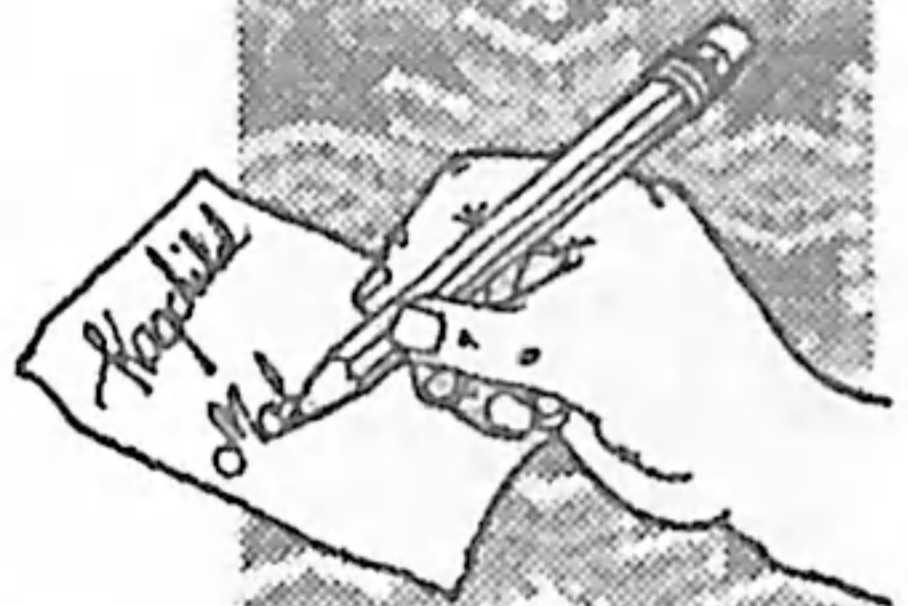





Nsamaj

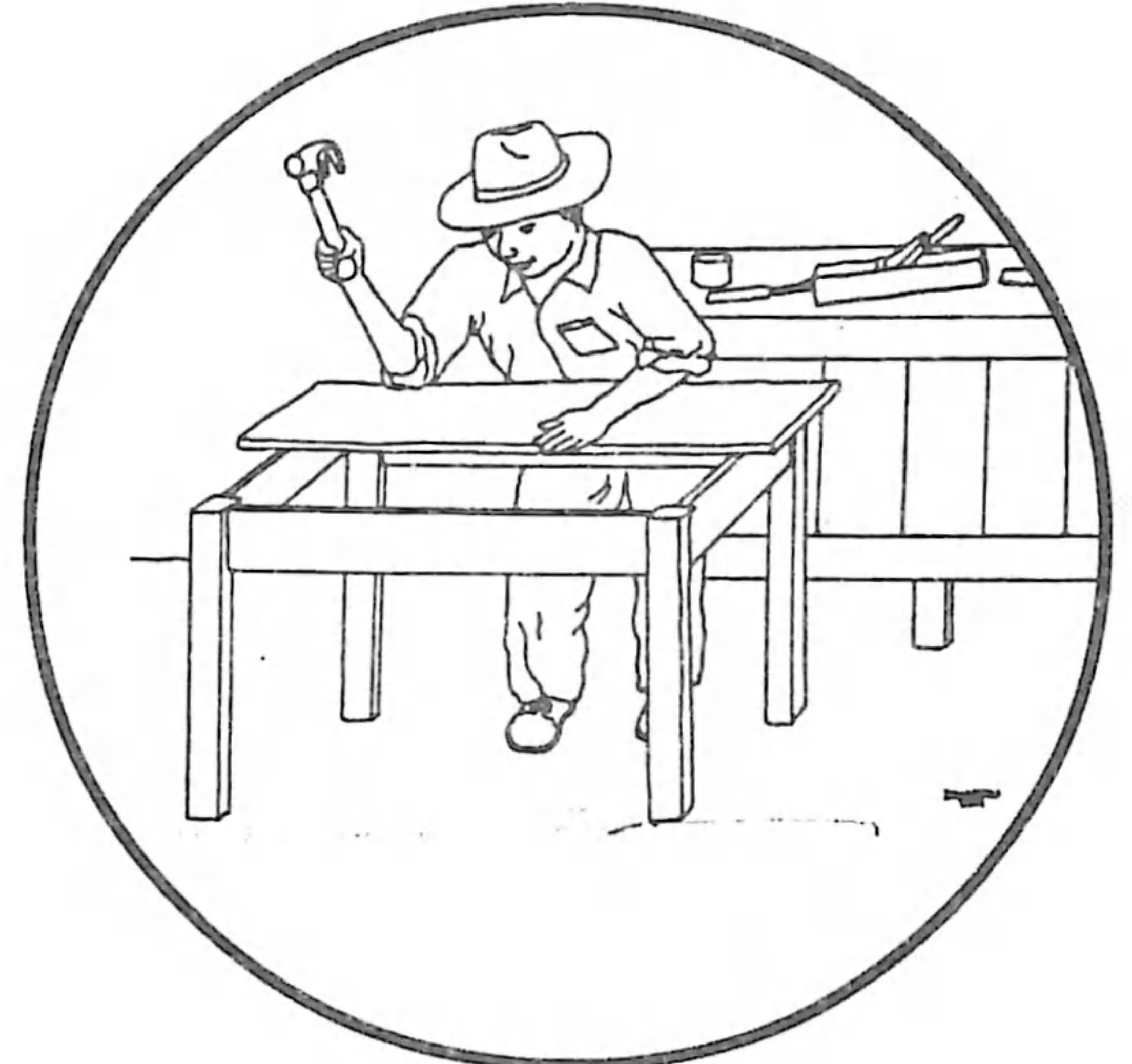

Ri tijoxela' ketzizon pa ruwi' jujun taq achib'äl

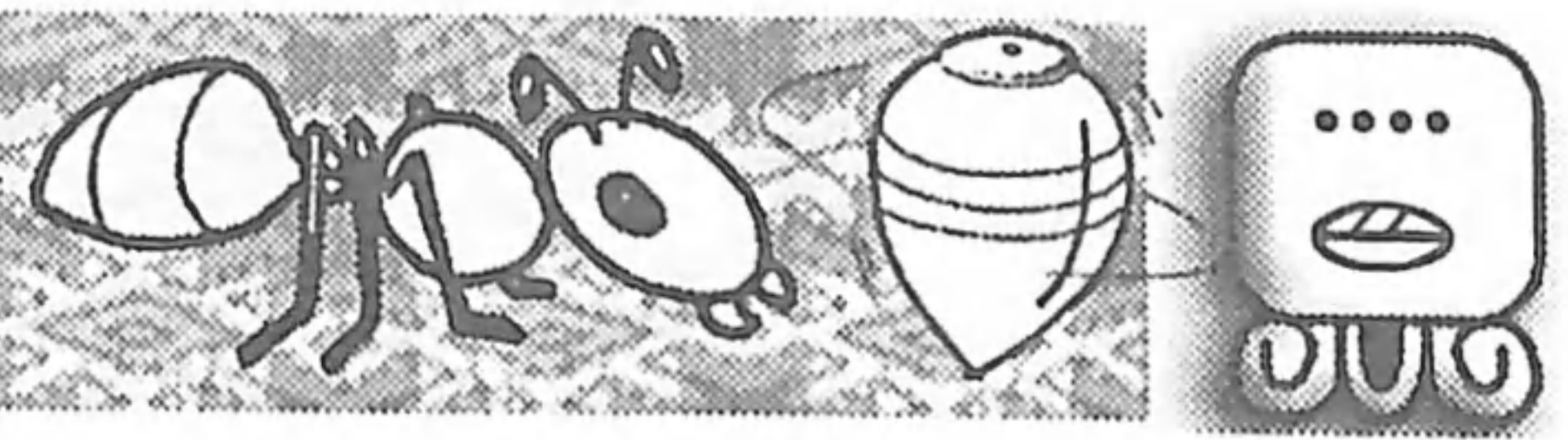
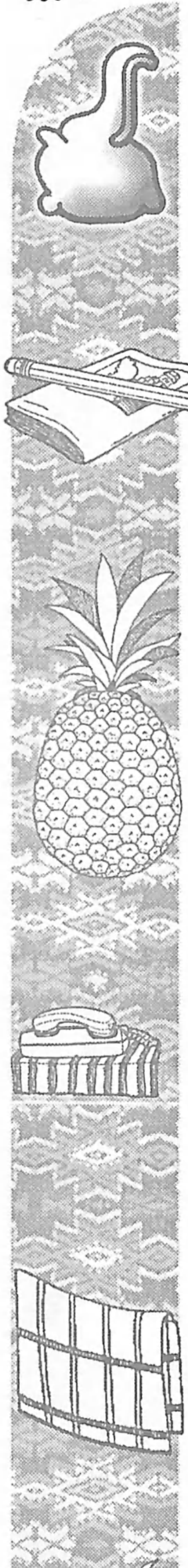

Nqab'än kachib'äl ri jalajöj samaj nkib'än ri qate' qatata'.

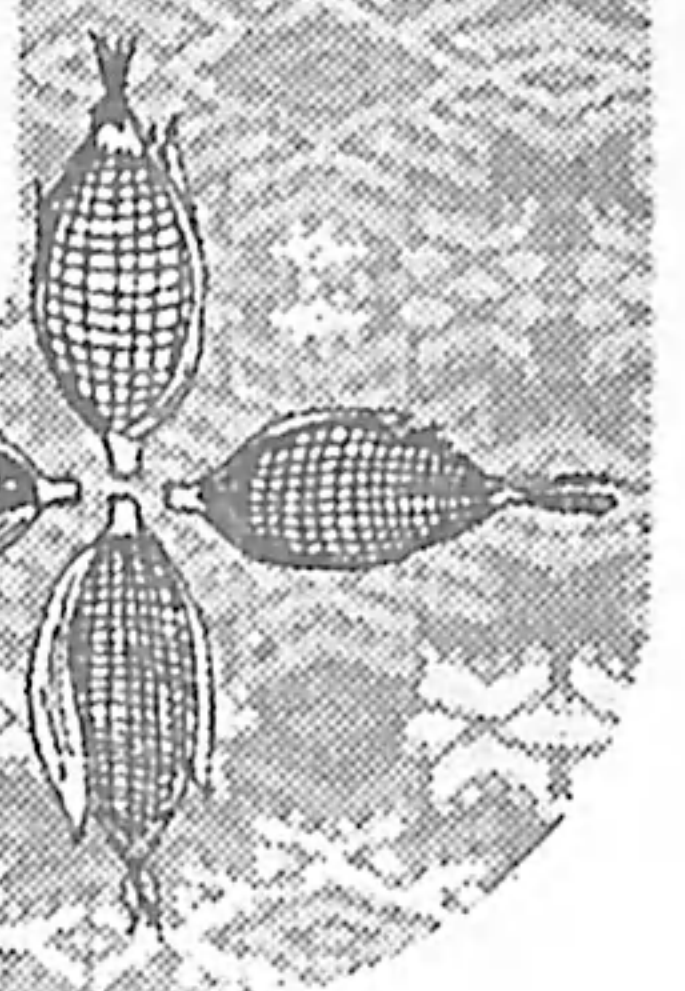
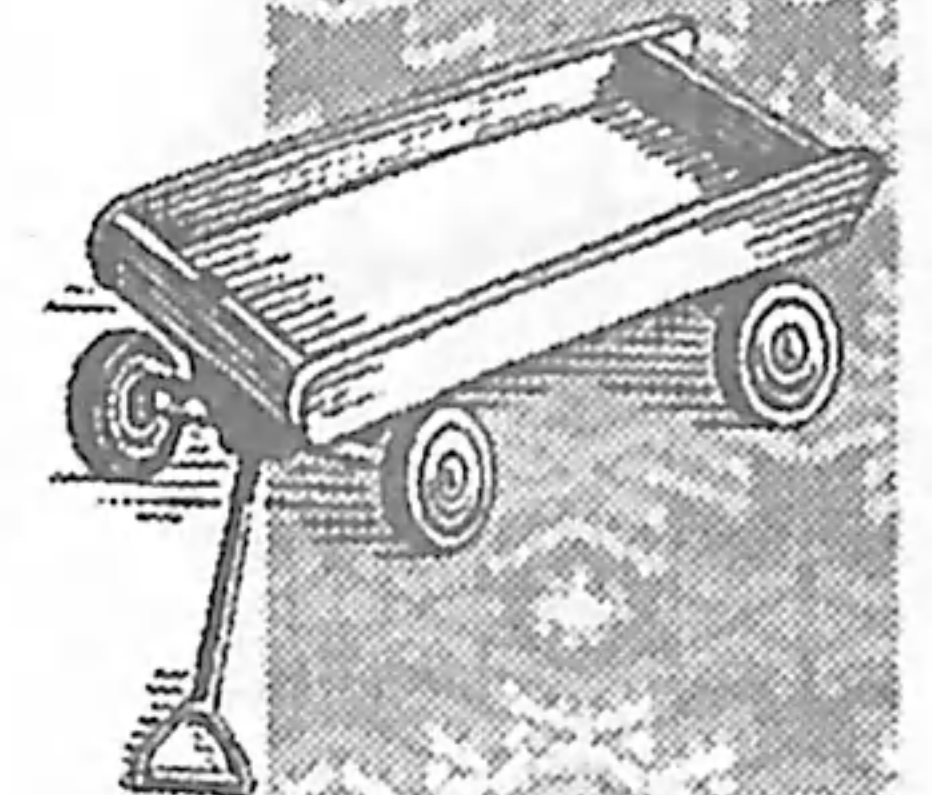
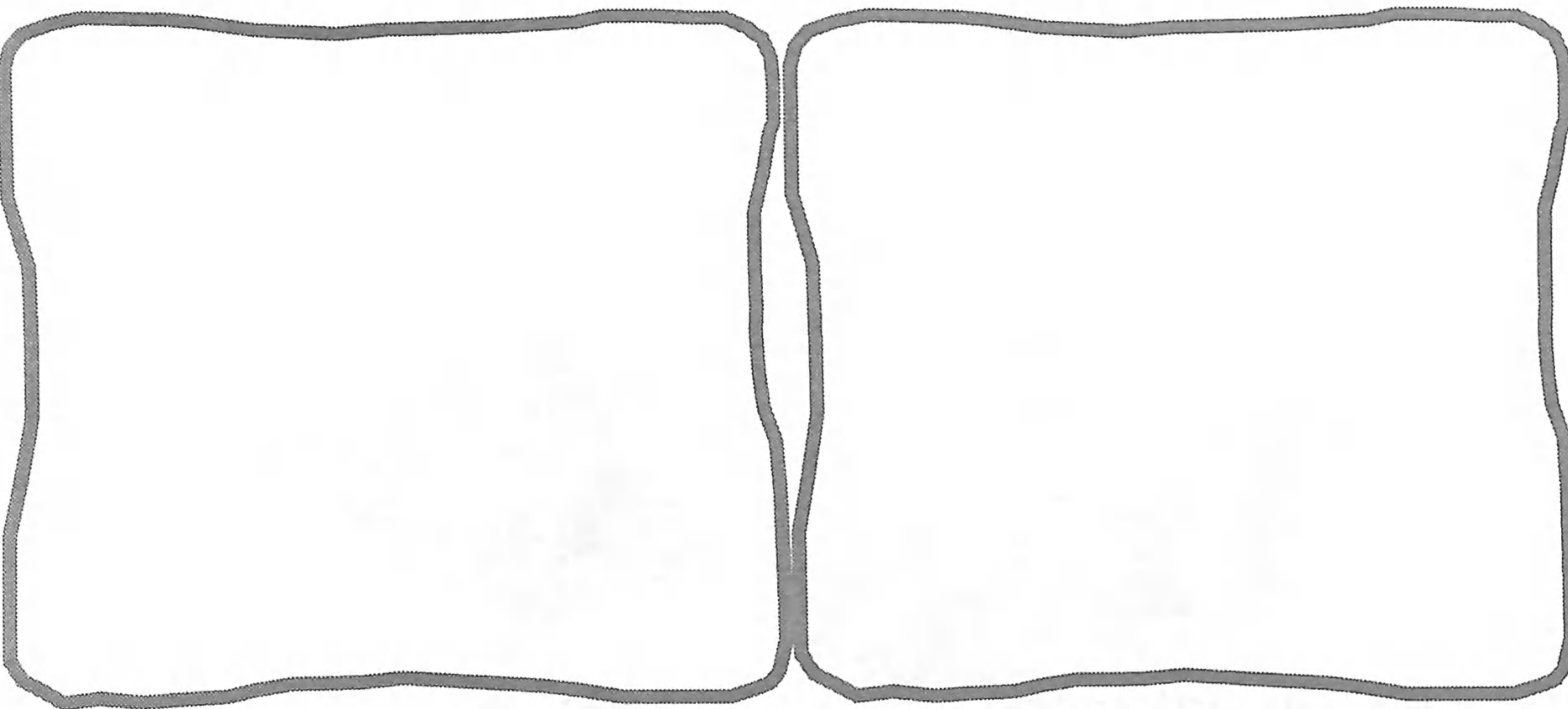
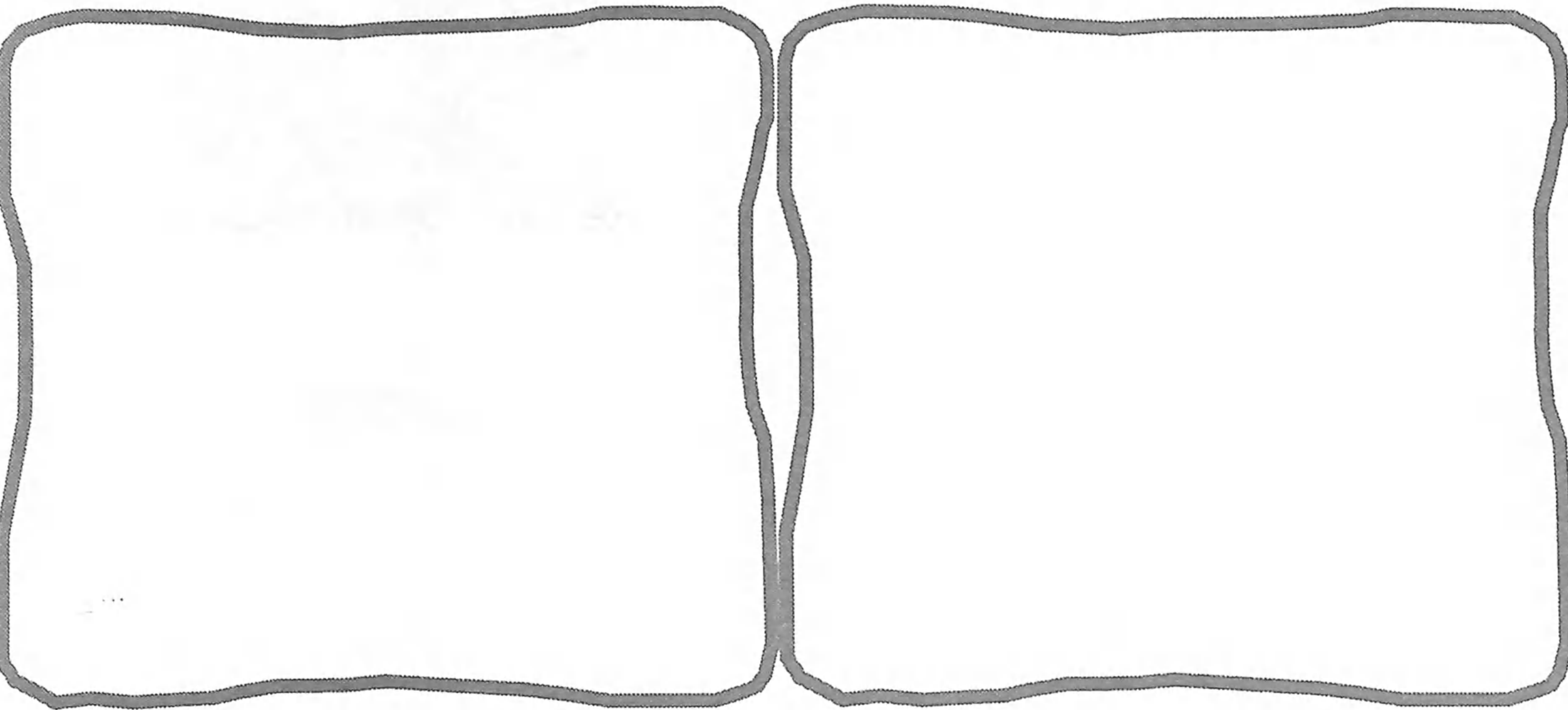

Ri tijoxela' nab'ey nkib'än kachib'äl pa ruwi' kisamaj kite' kitata',  
k'a ri' nkib'än jun etz'anem pa ruwi' ri samaj xkib'än.

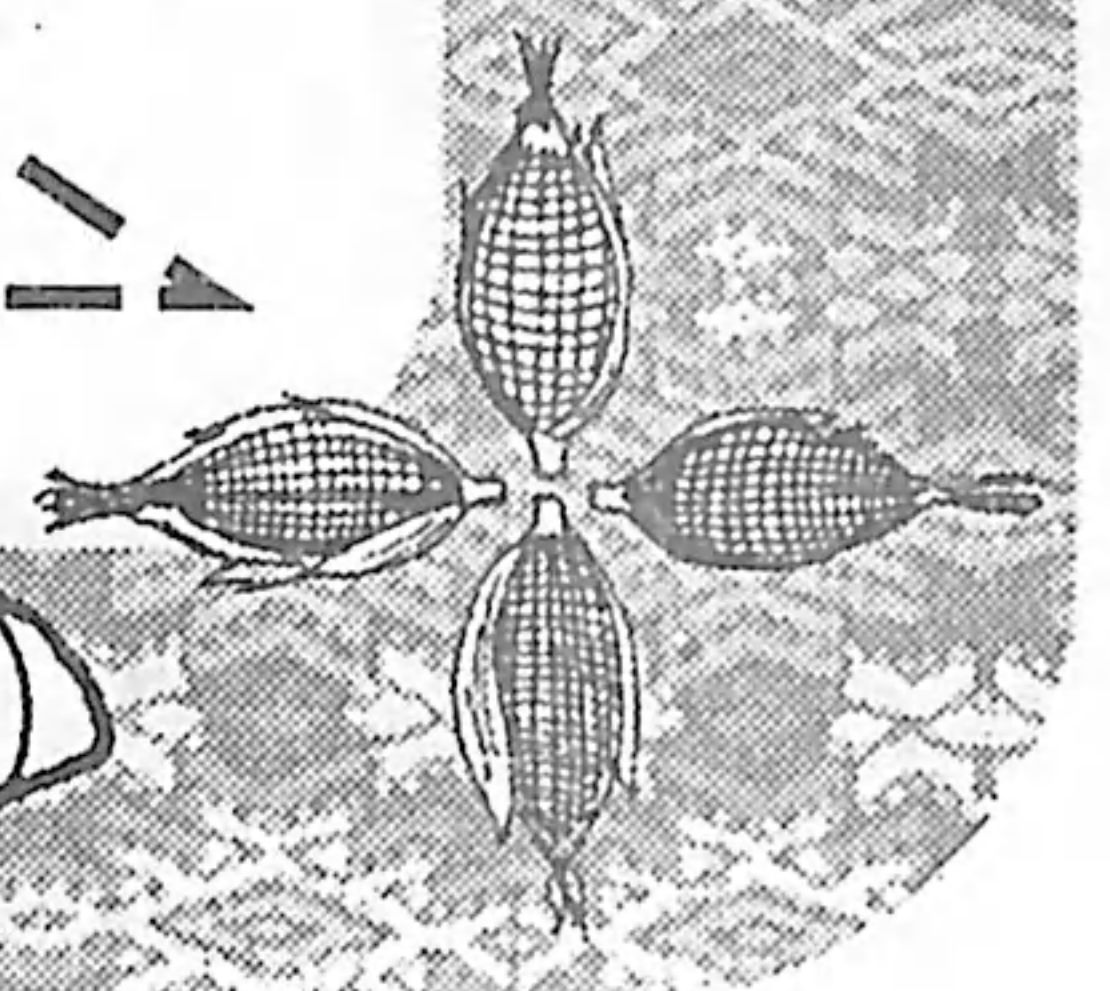

# Ri jalajöj ruwäch samaj

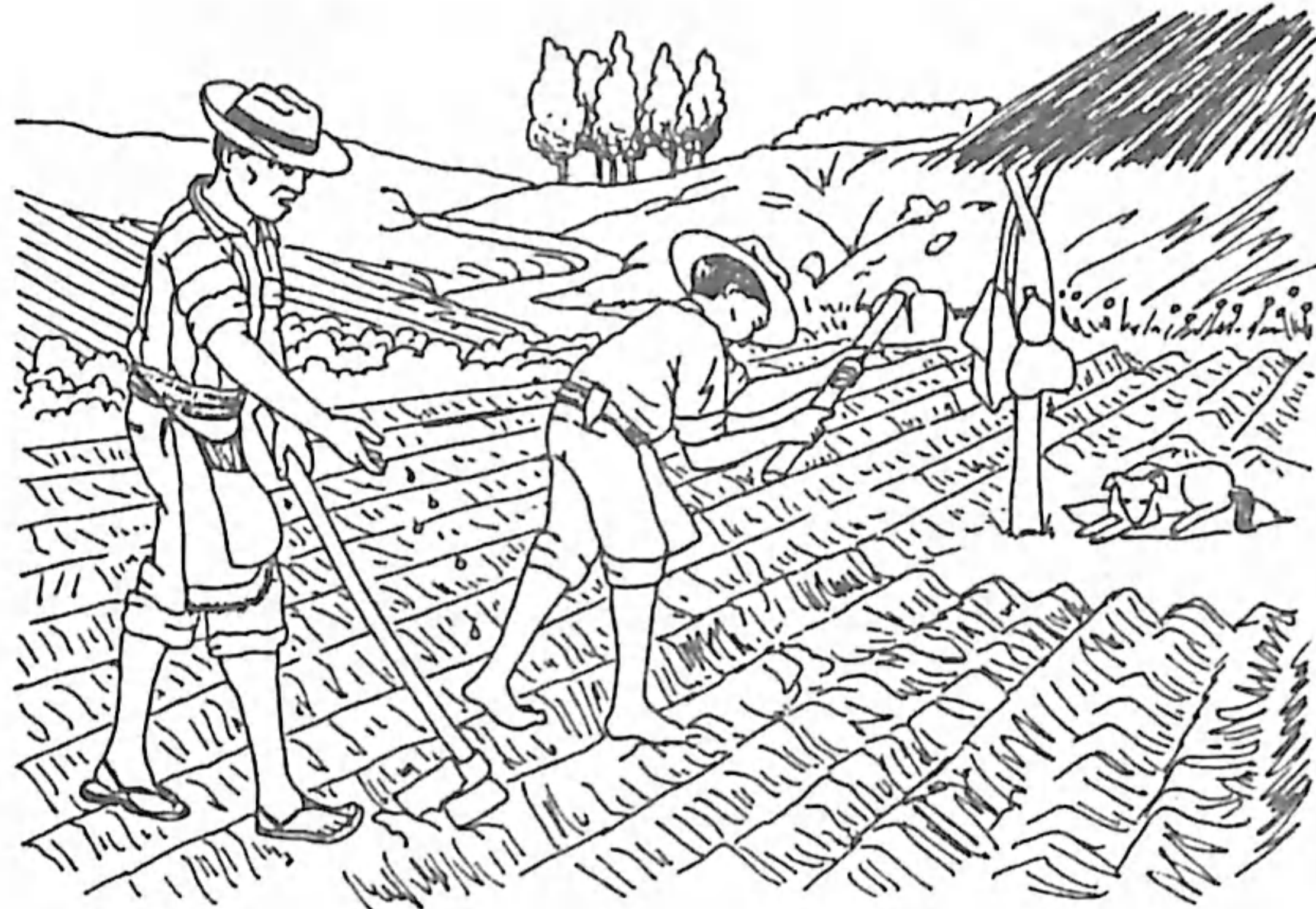

Re' jun tikonel



Re' jun ajsamajay



Re' jun ajtz' aq

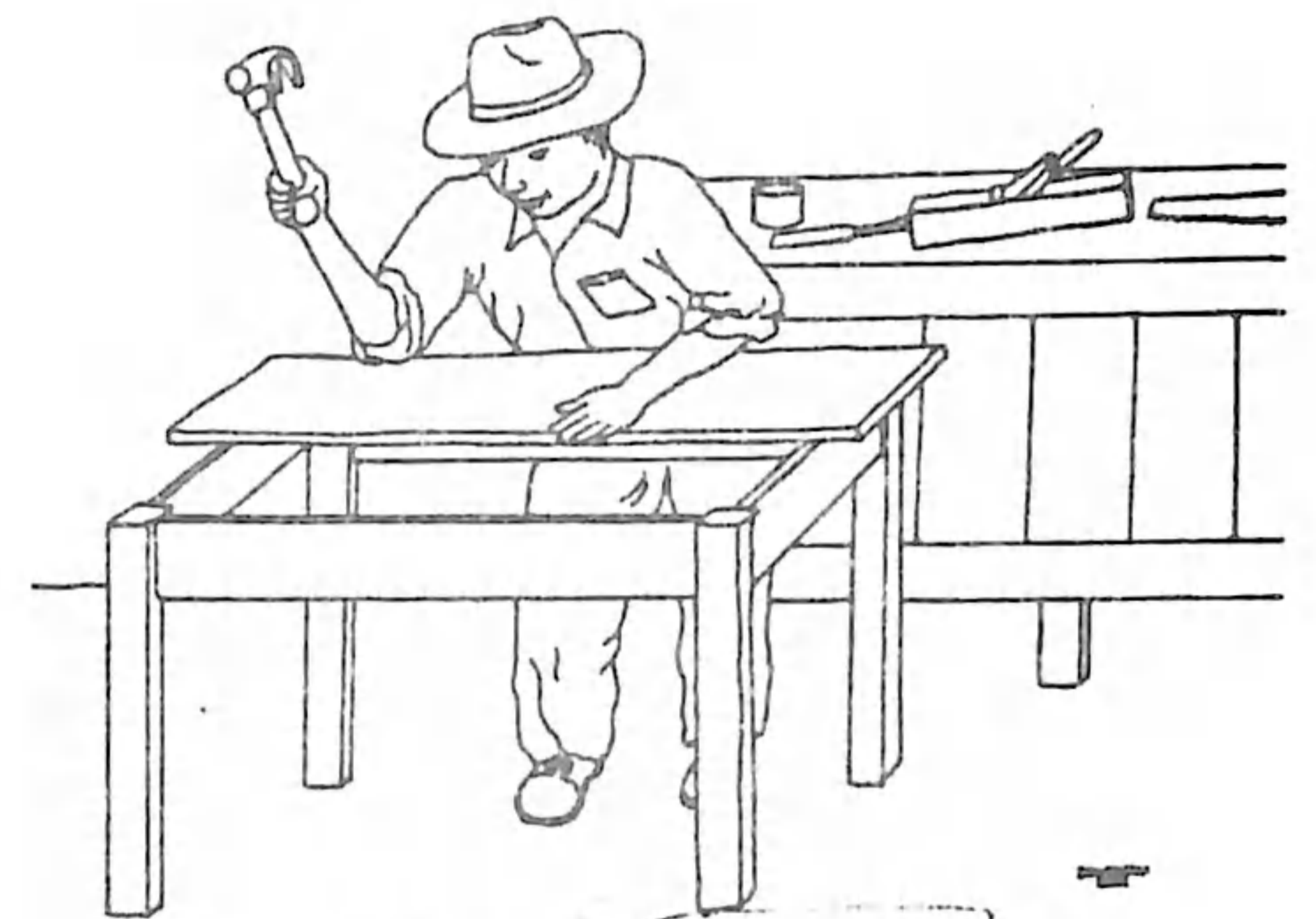

Re' jun ajanel



Re' jun aq' omanel



Re' jun k' ayinel

Ri tijonel tuya' ch' aqa chik tzij pa ruwi' ri jalajöj ruwäch samaj chi ke ri tijoxela'

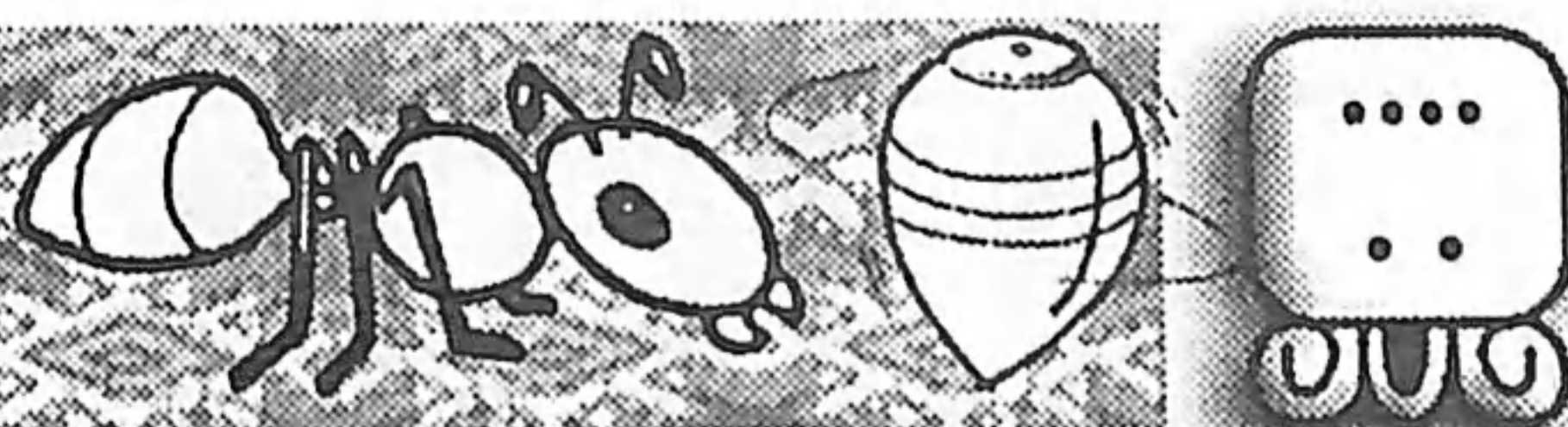

Tqetamaj ri rub'ixik jalajöj winaqilal



ixta



a (ala')



ma



ya



tat



nan



# Tqatz'eta' re ka'i' oxi' achib'äl re'



Ri Nwetamaj

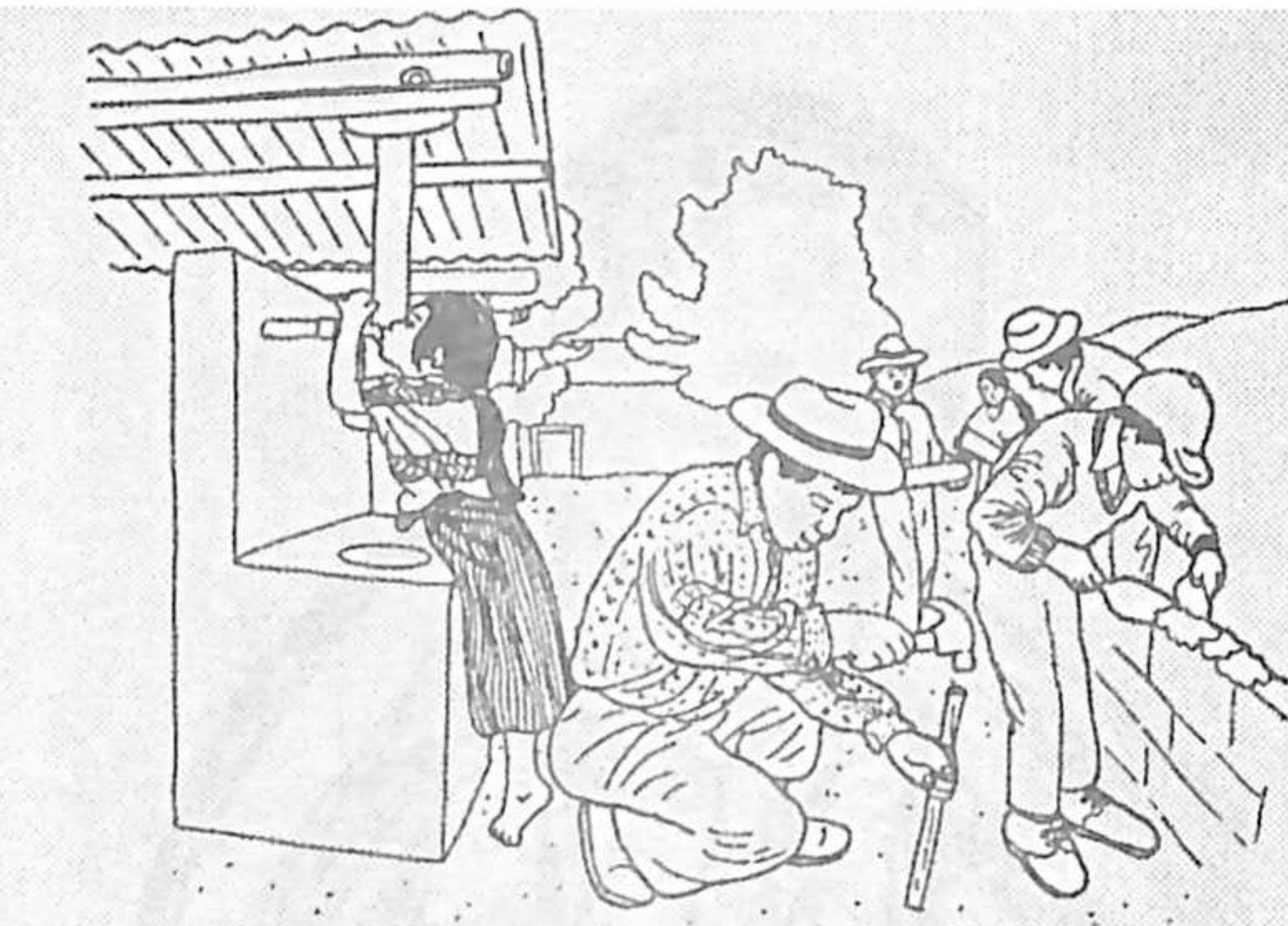
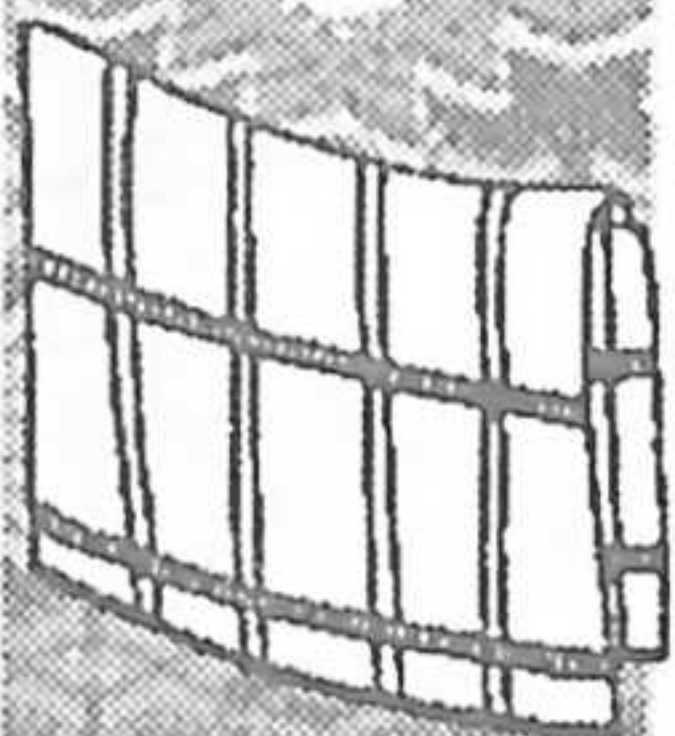

Ri ma Xwan ajtz'aaq



Ri ya Ixkem ajtz'ib'



Ri ixta Ixchel kelonel

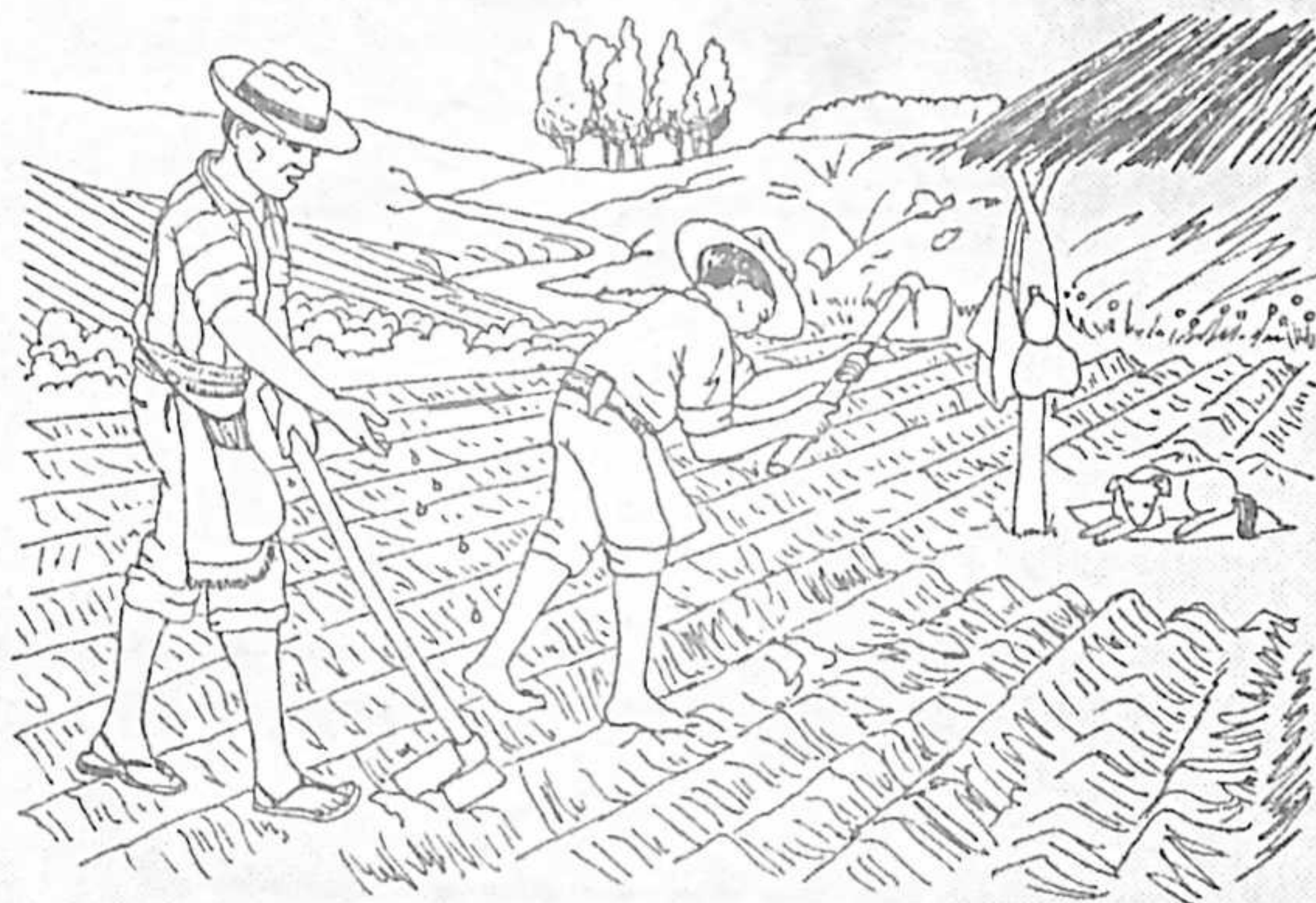

Tikonel ri a Lu'

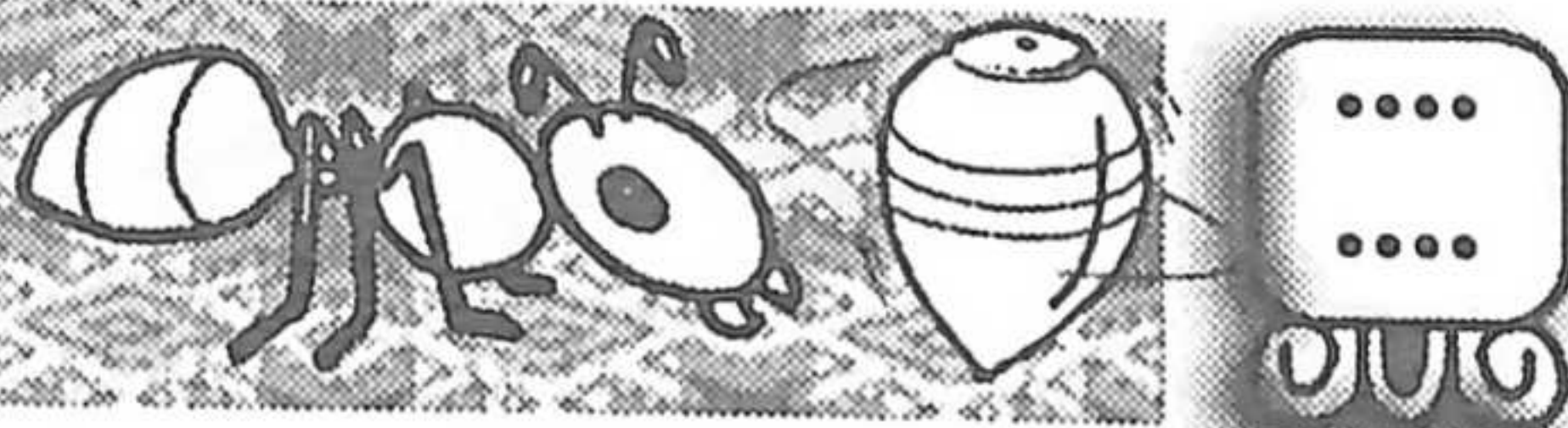

# Ri samaj yeb'an pa qochoch



Mesonik



qupinxik



atinik



Ch'ajch'onik



to'onik



B'oninik



Man tqamestaj achike ri winaqilal k'o chi nqokisaj richin ri alab'oni', ixtani', ri nima'q.



Ri Nwetamaj

Kojtzijon: Ri tijoxela' nkib'an jun tzijonem chi kiwäch.

Kanek: La awetaman yaq'ojoman rat Nik'te'?

Nik'te': Manäq, rin ützninna'yenb'onij achib'äl.

Kanek': Rin ninq'ojomaj ri tilin b'atz'.

Nik'te: Ri nuchaq' retaman nq'ojoman.

Kanek: Achike ruwäch q'ojom nuq'ojomaj ri achaaq'?

Nik'te': Nuq'ojomaj xul b'atz'.

Nikte': Ri nute' nub'ij chi ri kem, jun jeb'äl samaj.

Kanek: Ri nuch'utite' retaman nkemon.

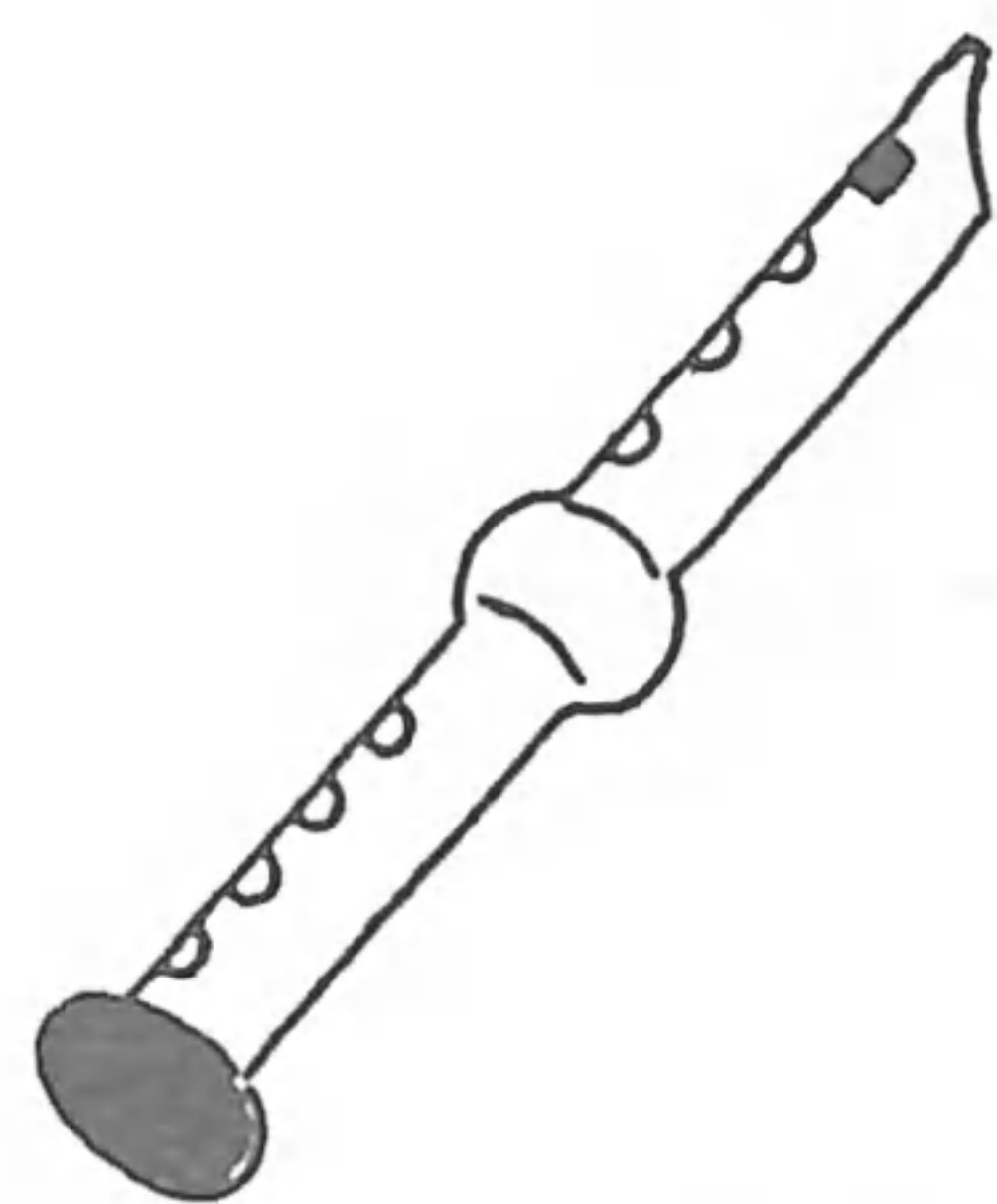
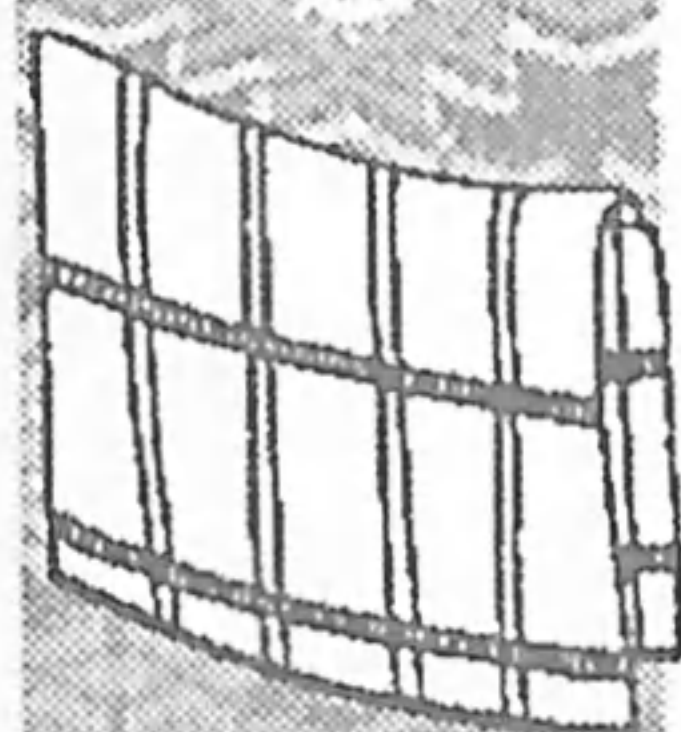

xul



ajanel



xajoj

Yeqajäch ri tijoxela' pa kaka' richin yetzijon chi kiwäch.

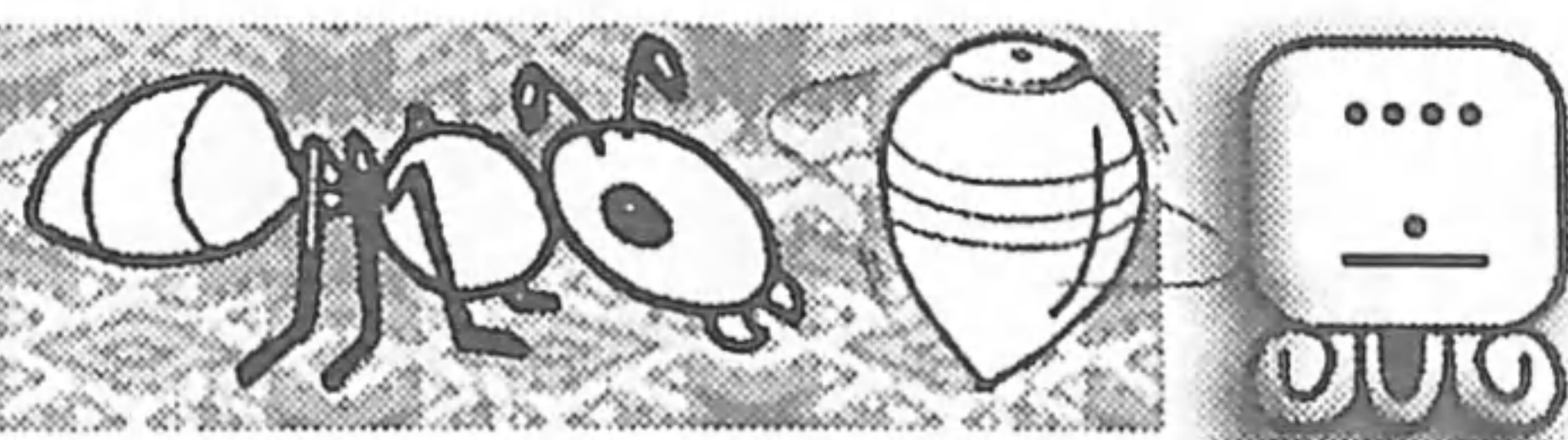

# Kojsamäj qonojel: Tqetamaj re b'anoj re'

Ramaj richin wakami

Yin-  
Yat-  
N-  
Yoj-  
Yix-  
Ye-

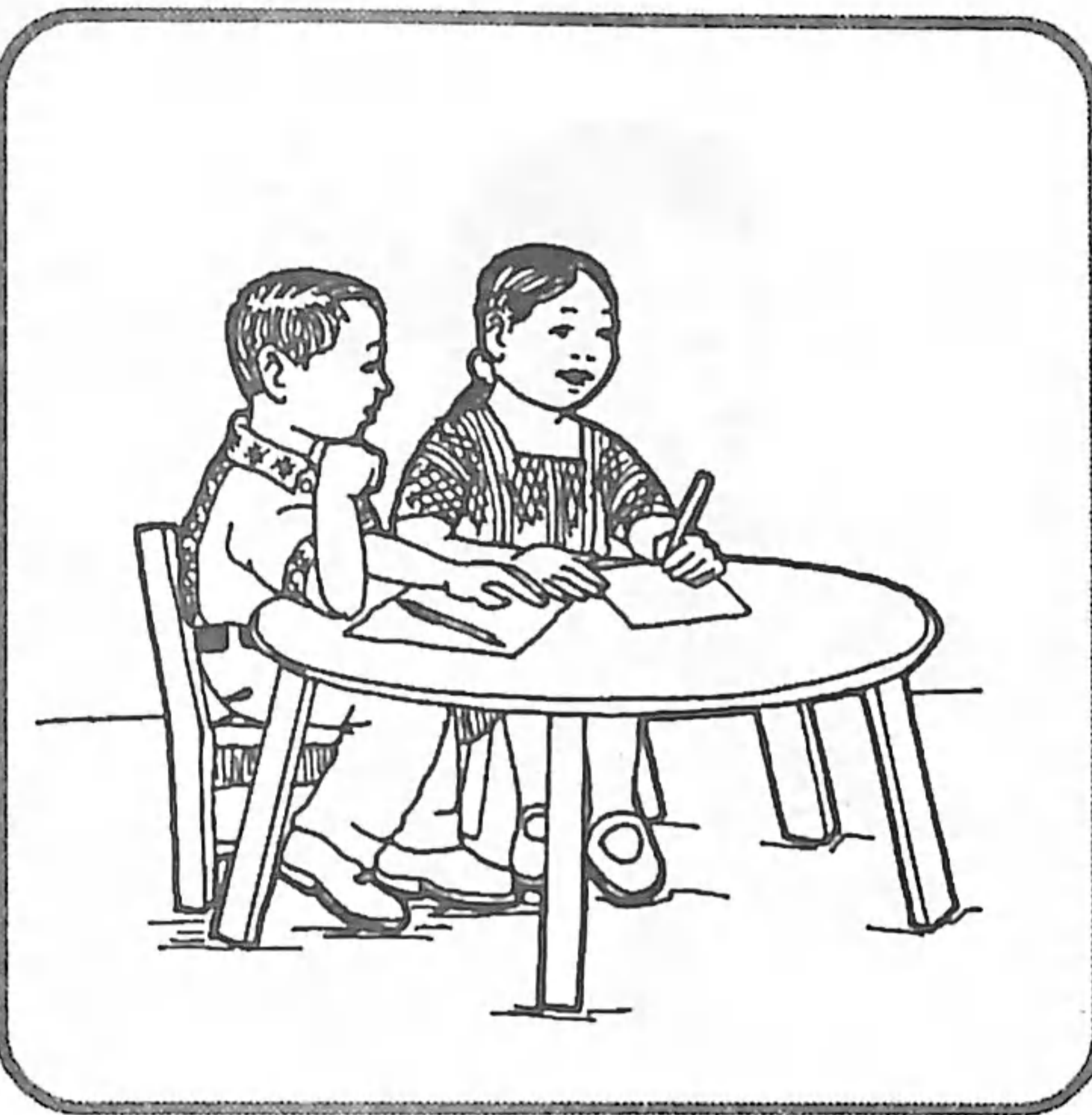

Tz'ib'an



Ramaj richin iwir

xin-  
xat-  
x-  
xoj-  
xix-  
xe'-

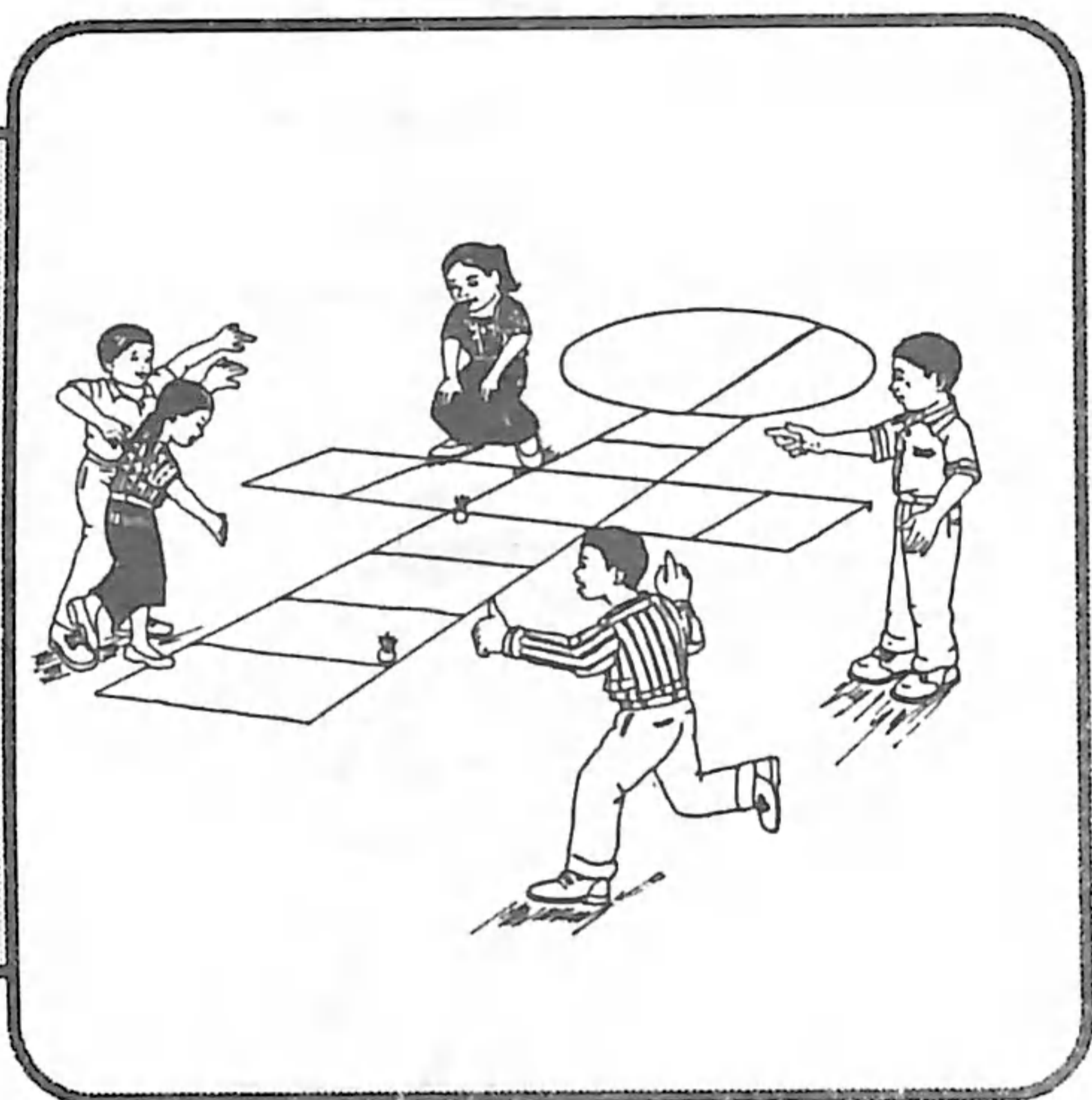

Etz'an

Ramaj richin apo

xkin-  
xkat-  
xt-  
xoj-  
xix-  
xe'-



atin

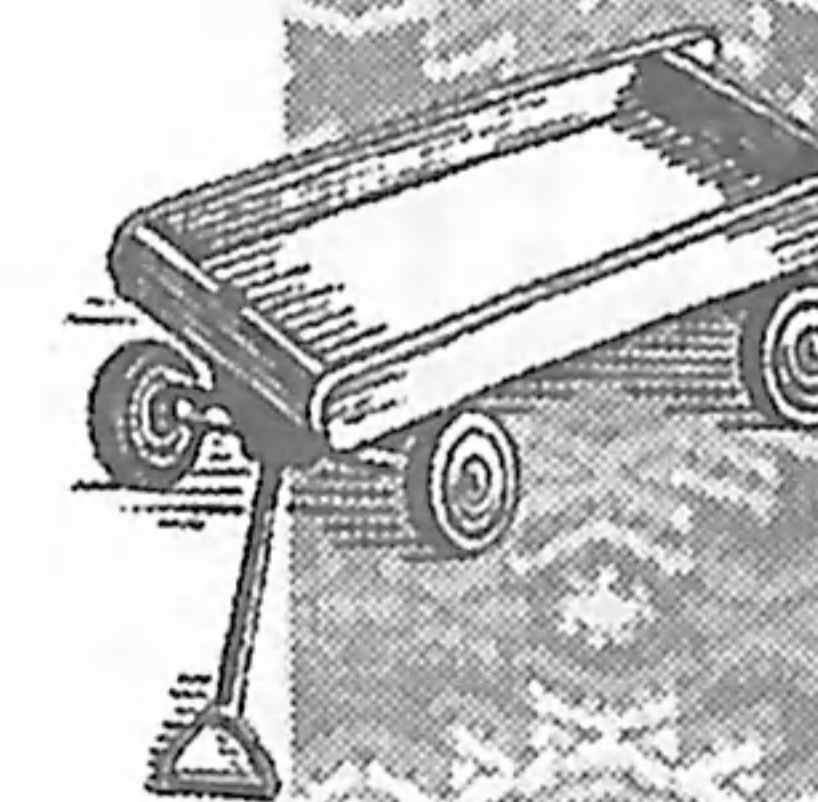
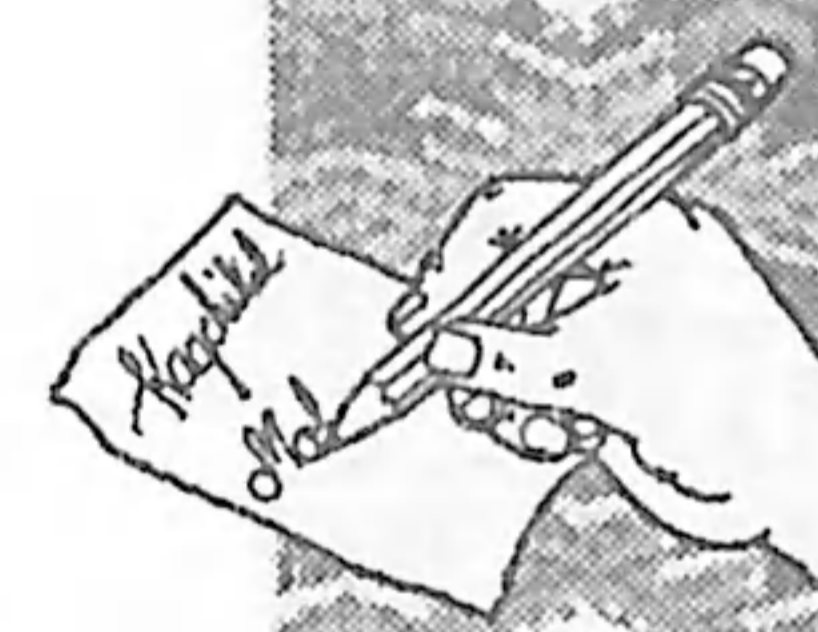
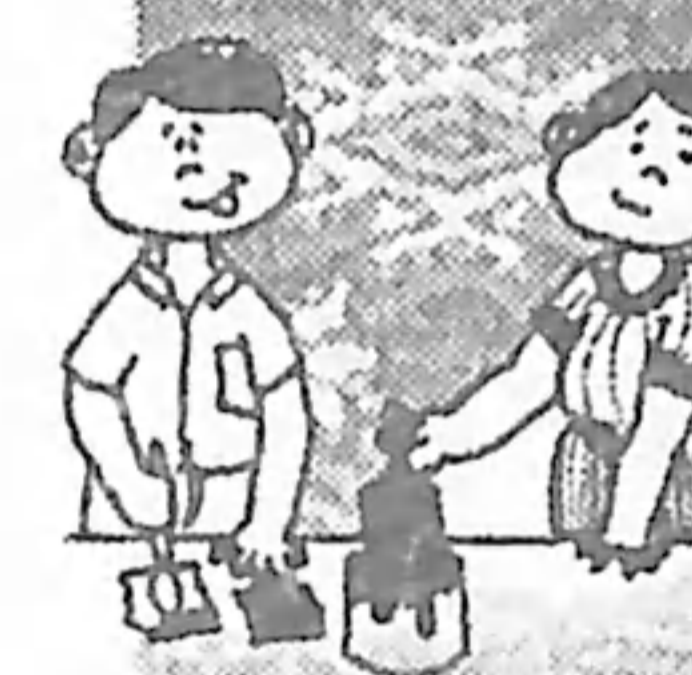

Ri tijoxela' yetzizon chi kiwäch richin nketamaj ri jalajöj q'ijul, pa ruwi' re na'oj re' tikirel nkib'än etz'anem.





# Ri kisamaj nkib'än ri winaqi'



Ri Xinwetamaj



B'ixanel ri \_\_\_\_\_



Ajtz' aq ri \_\_\_\_\_



K'amöl b'ey ri \_\_\_\_\_ Ixchel



Tikonel ri \_\_\_\_\_ B'alam

Ri tijoxela' nkitz'ib'aj ri winaqilal chuwäch ri juch'

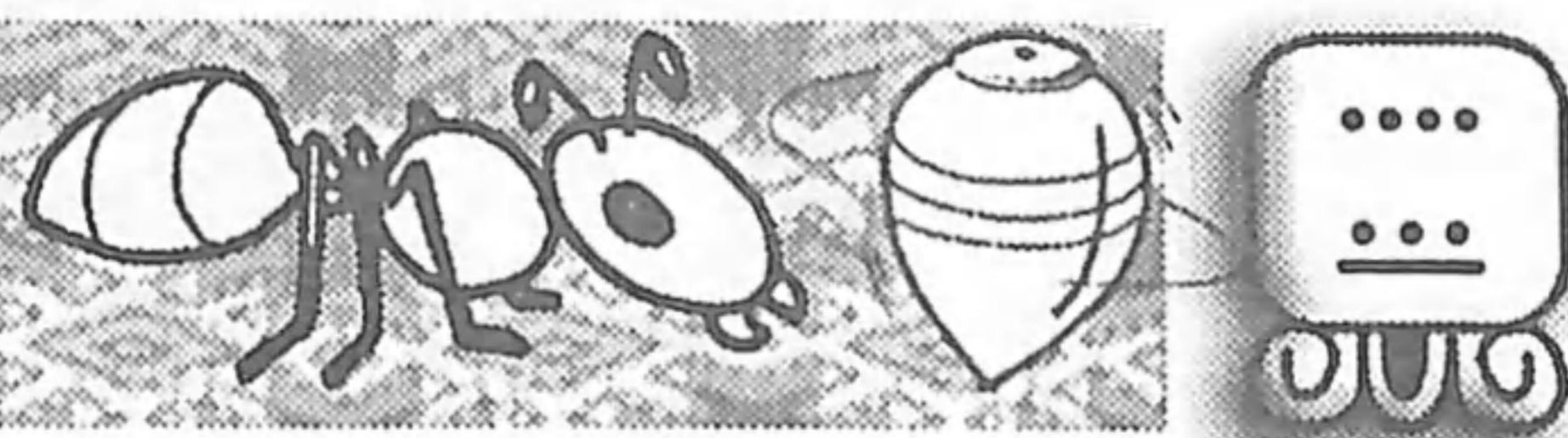

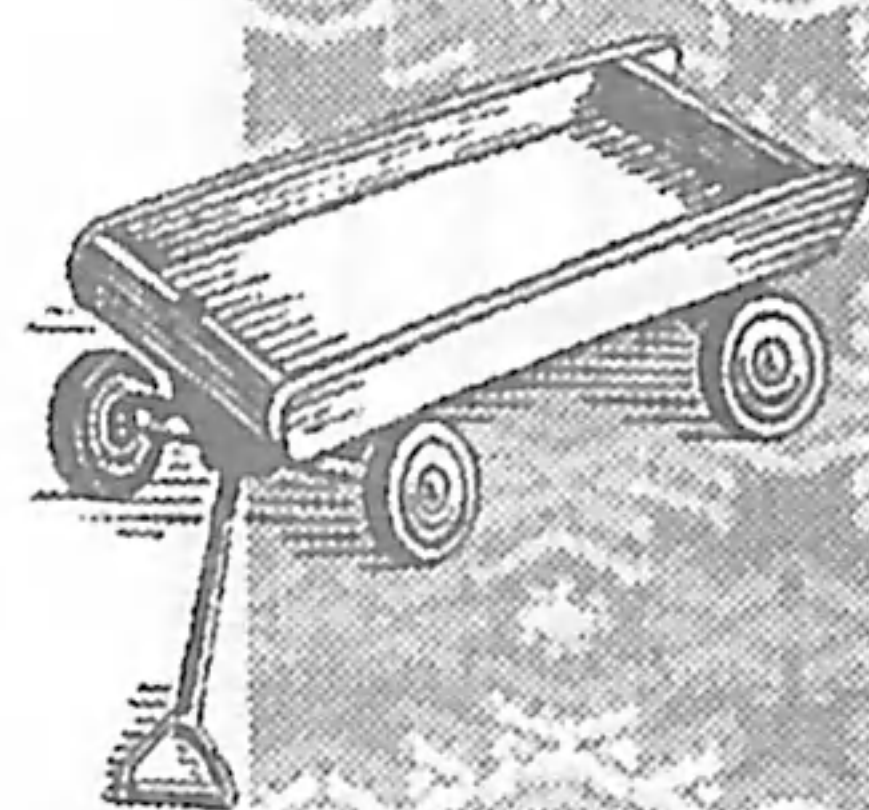
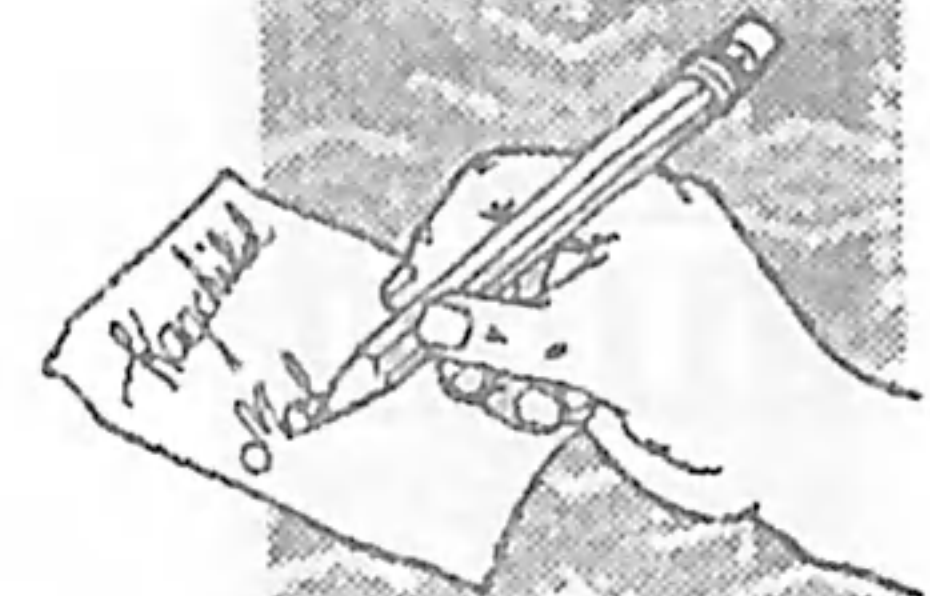
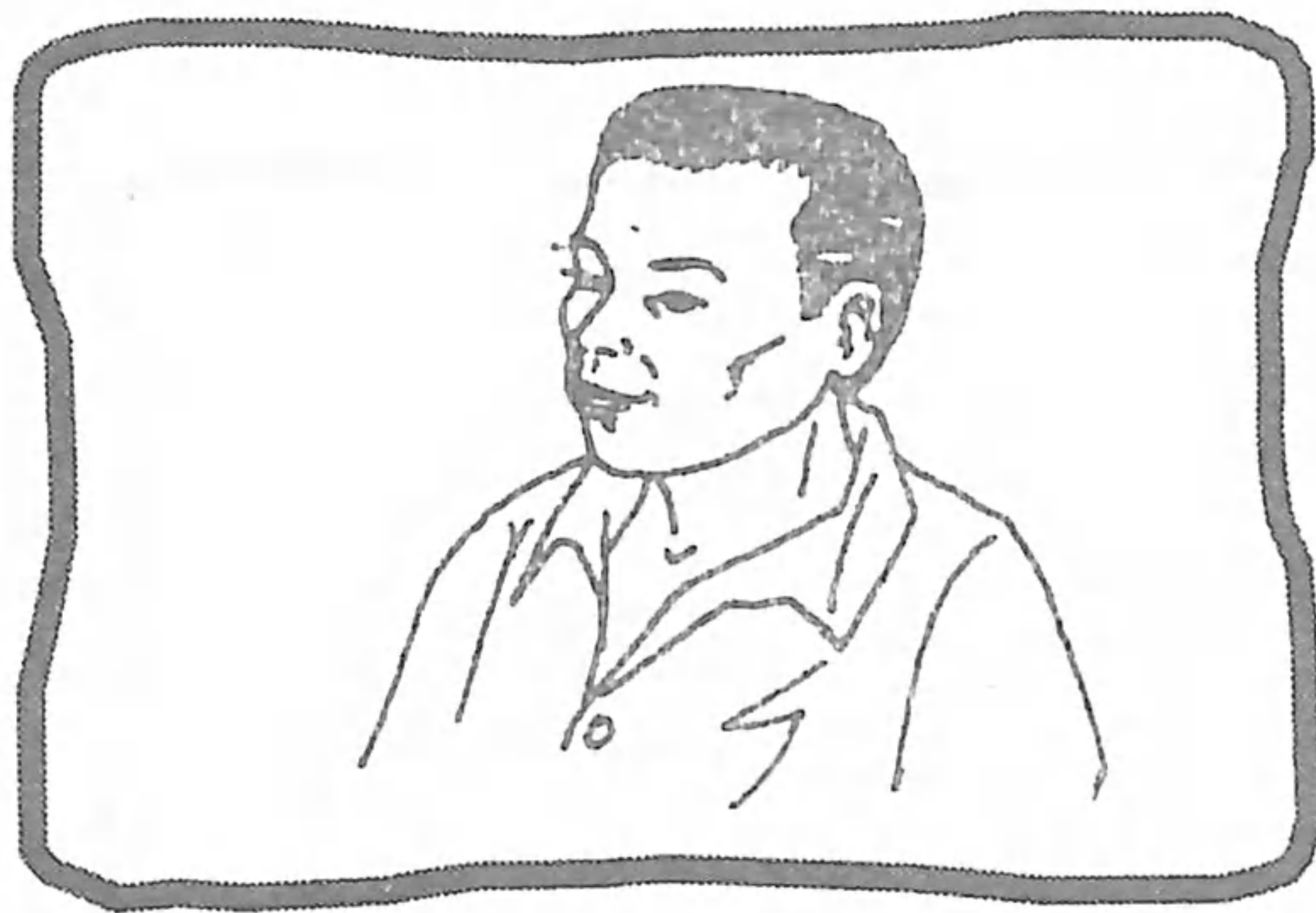
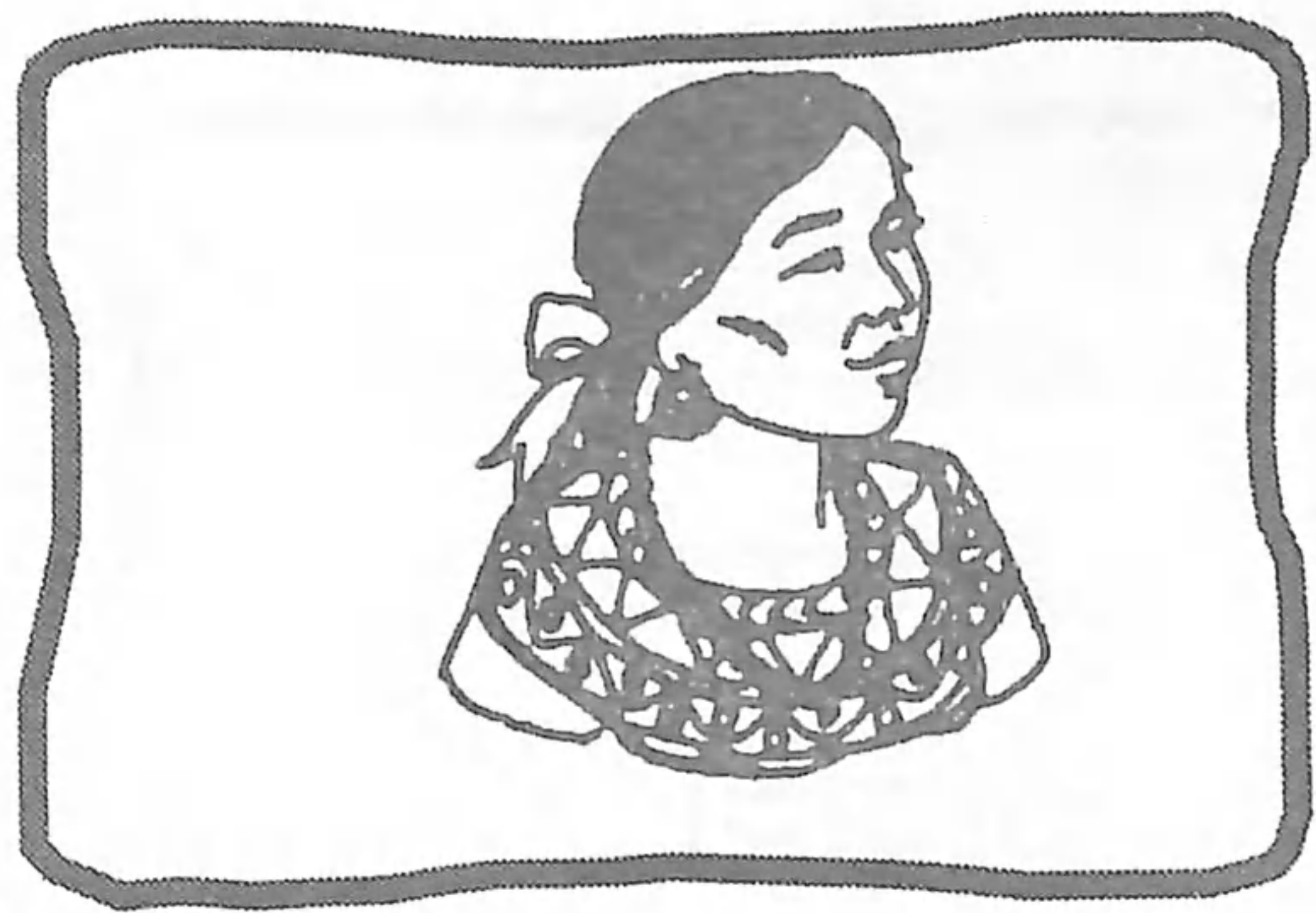

Ri tijoxela' nkitz'ib'aj pa taq juch' kib'i' kiwinaqilal re achib'äl re'.



# Tojtojb'enik

Tqatz'ib'aj ri jalajöj ruwäch samaj



Ri Xinwetamal

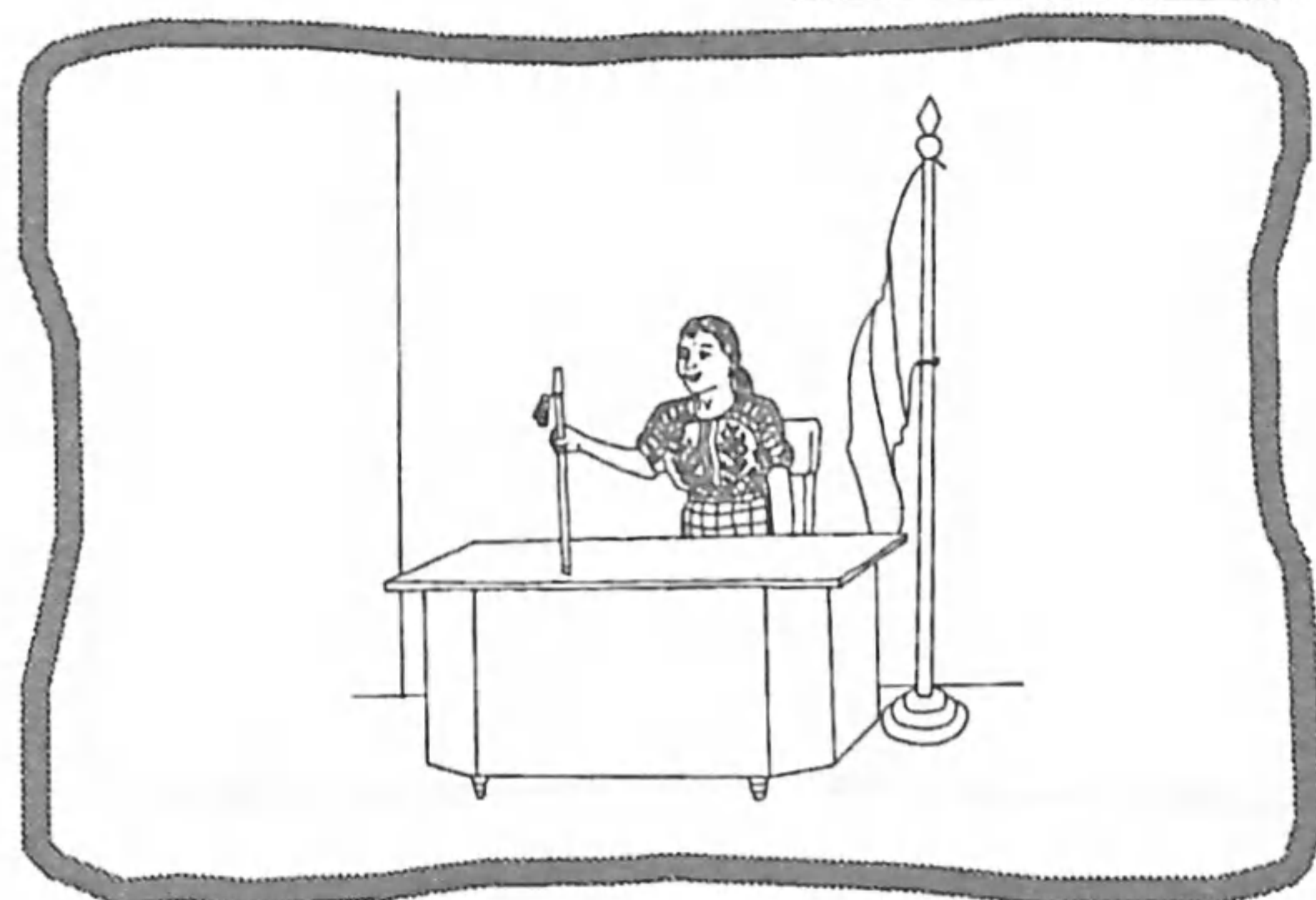
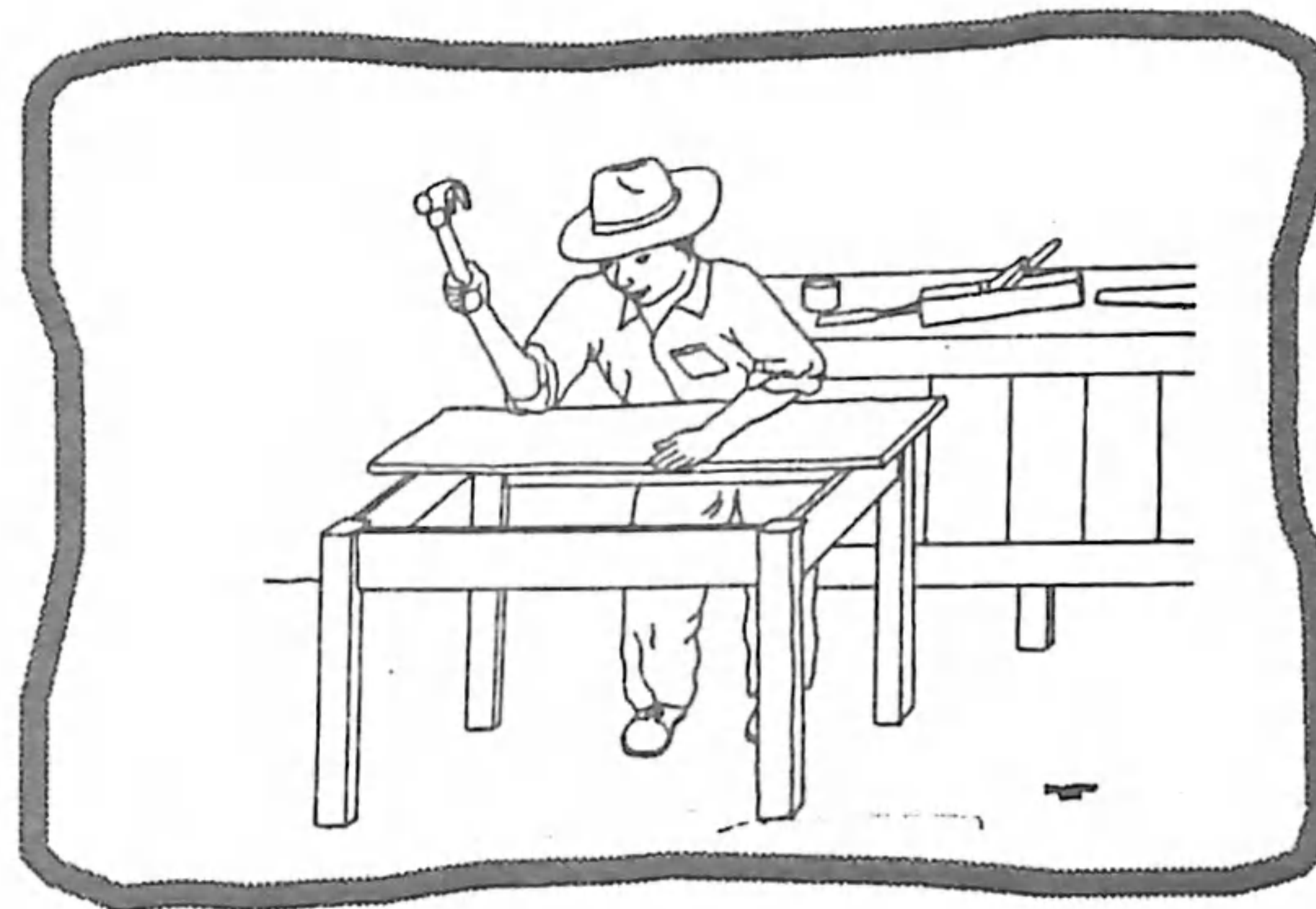

K'amöl b'ey ri \_\_\_\_\_ lxchel

Tijonel ri \_\_\_\_\_ B'alam

Tqatz'ib'aj pa taq juch' ri nk'utux.



# RUWAQXAQ TANAJ

## Jalajöj ruwäch tiko'n

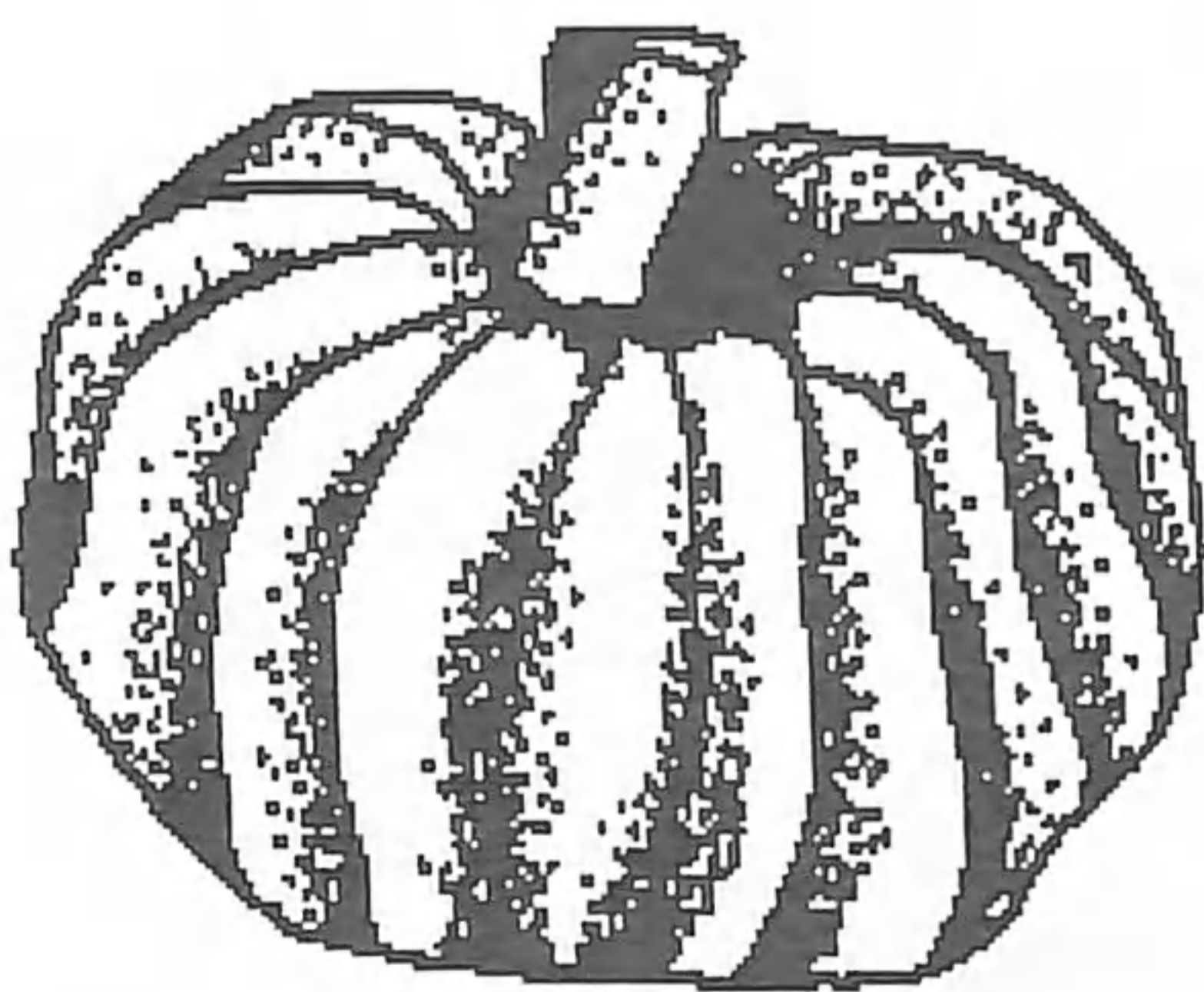
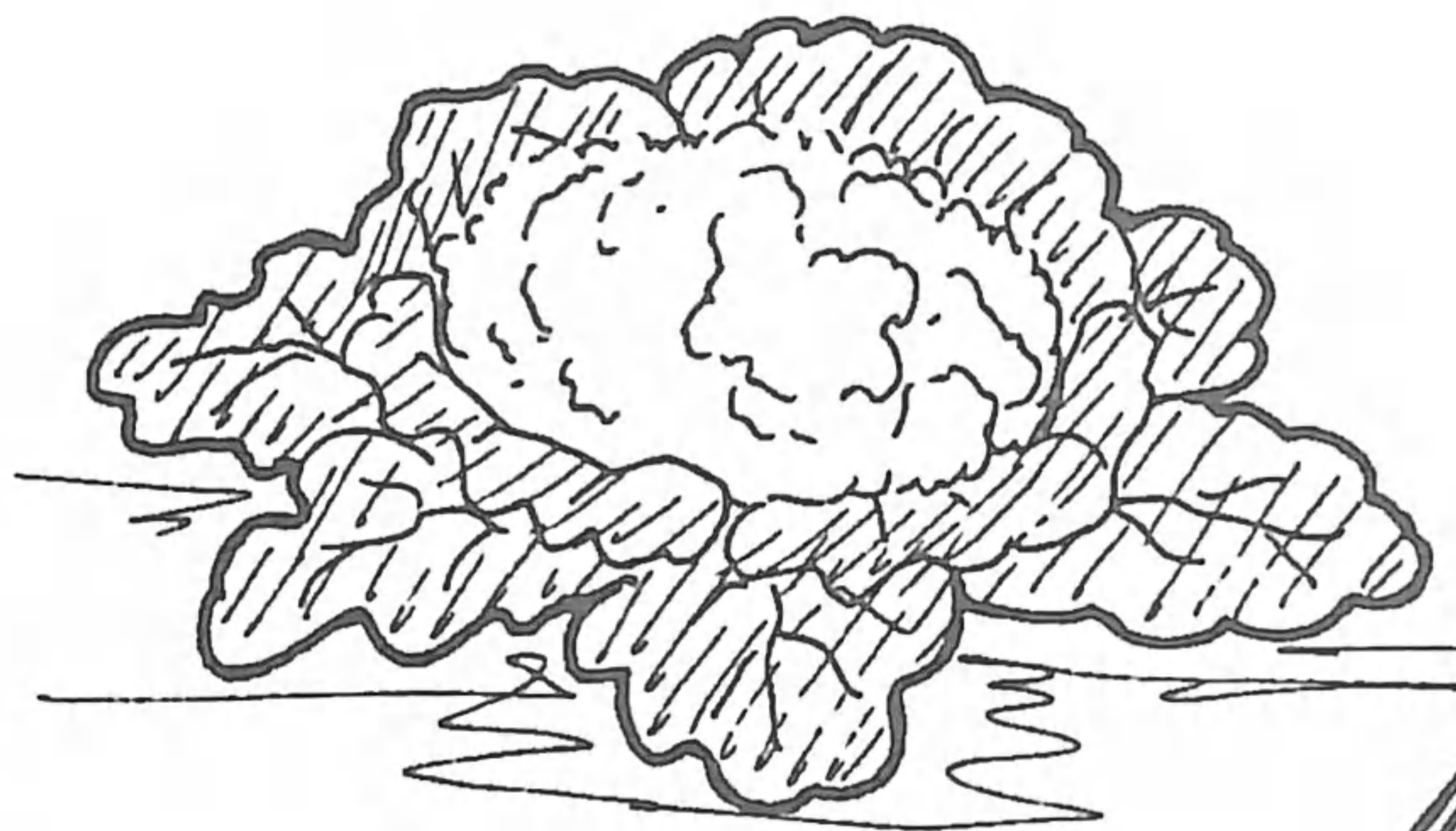
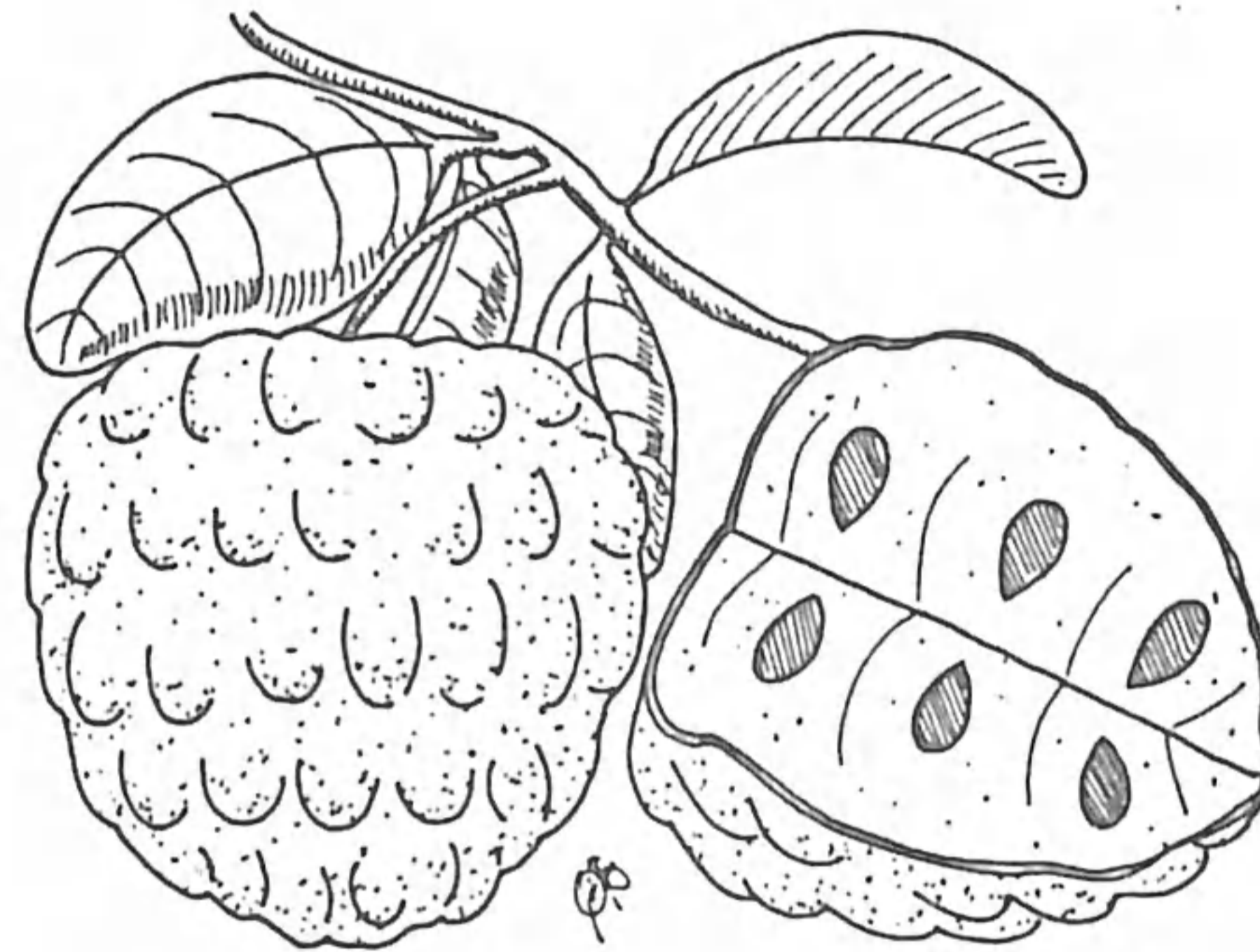
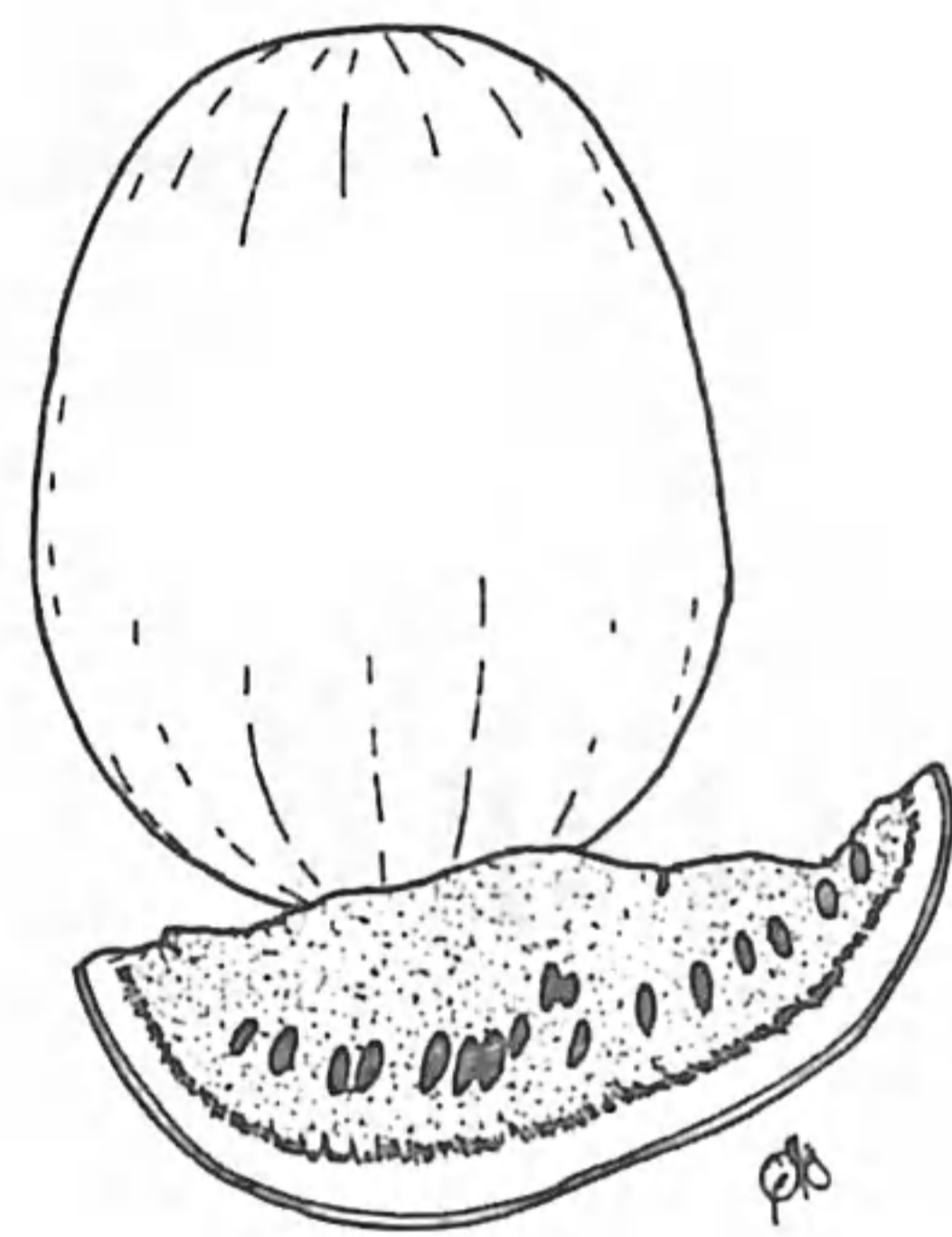
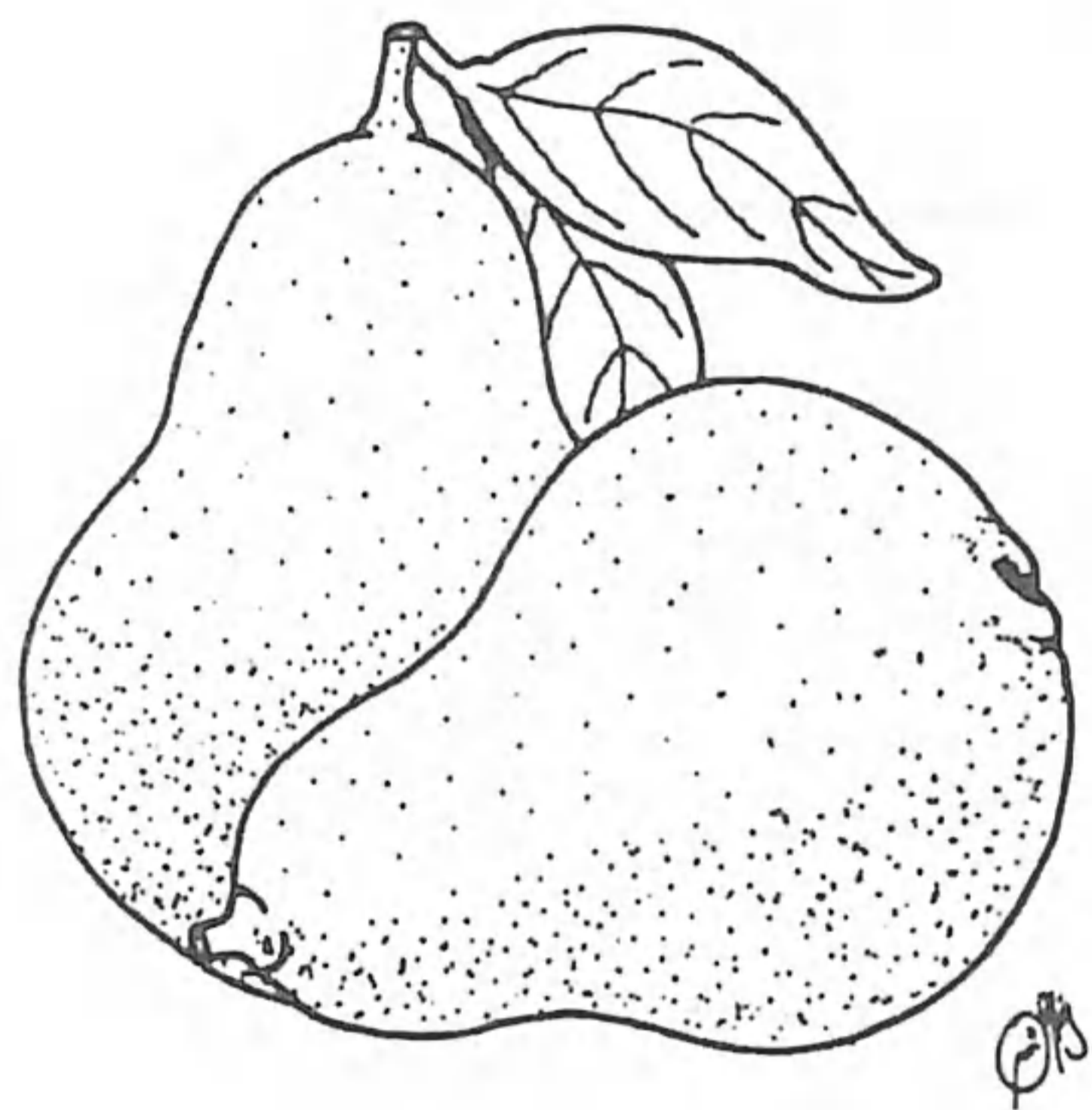

### Ri etamanik nuq'i' ri tijoxel:

Kib'i' ri jalajöj ruwäch tiko'n ri yek'ase' pa saq'ij chuqa' pa jäb'.

Ri jalajöj ruwäch jiq'ob'äl

Kib'i' ri jalajöj ruwäch tiko'n.

Ri ulew akuchi yek'ase' wi ri jalajöj taq tiko'n.

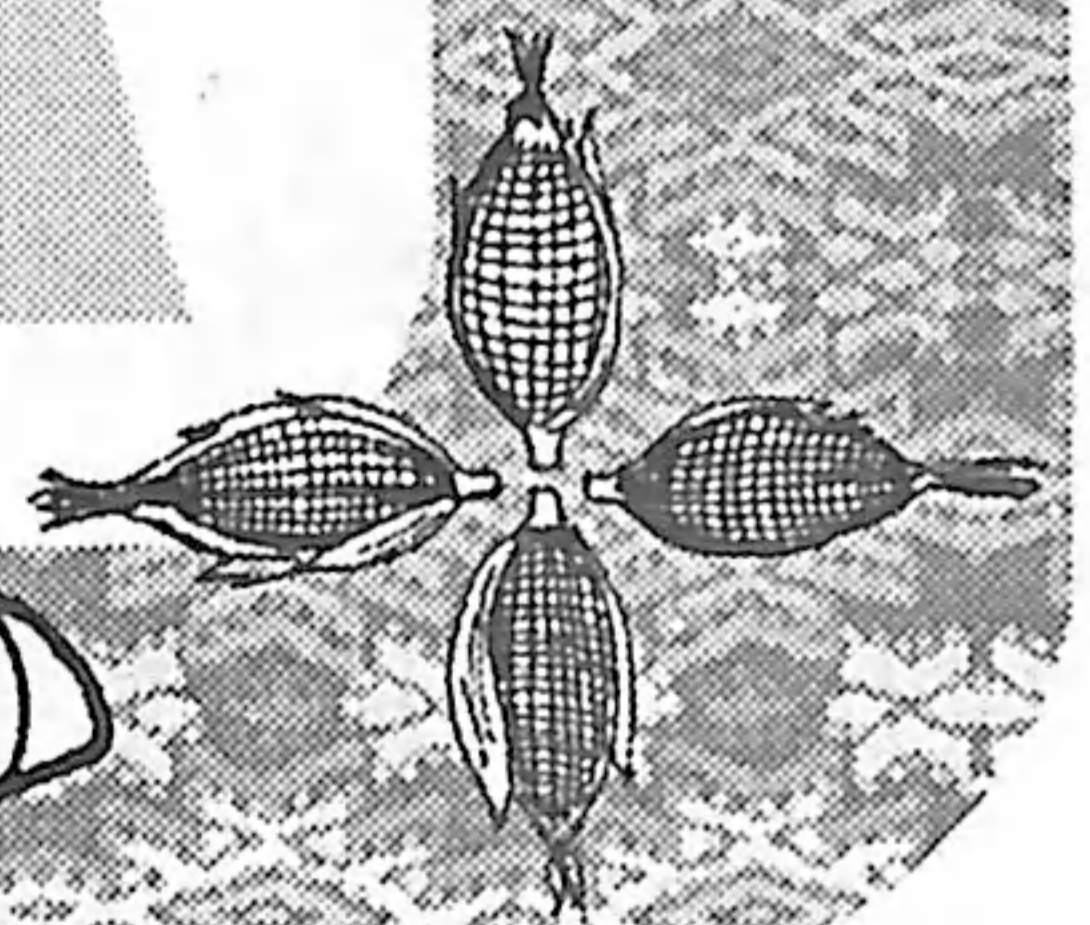
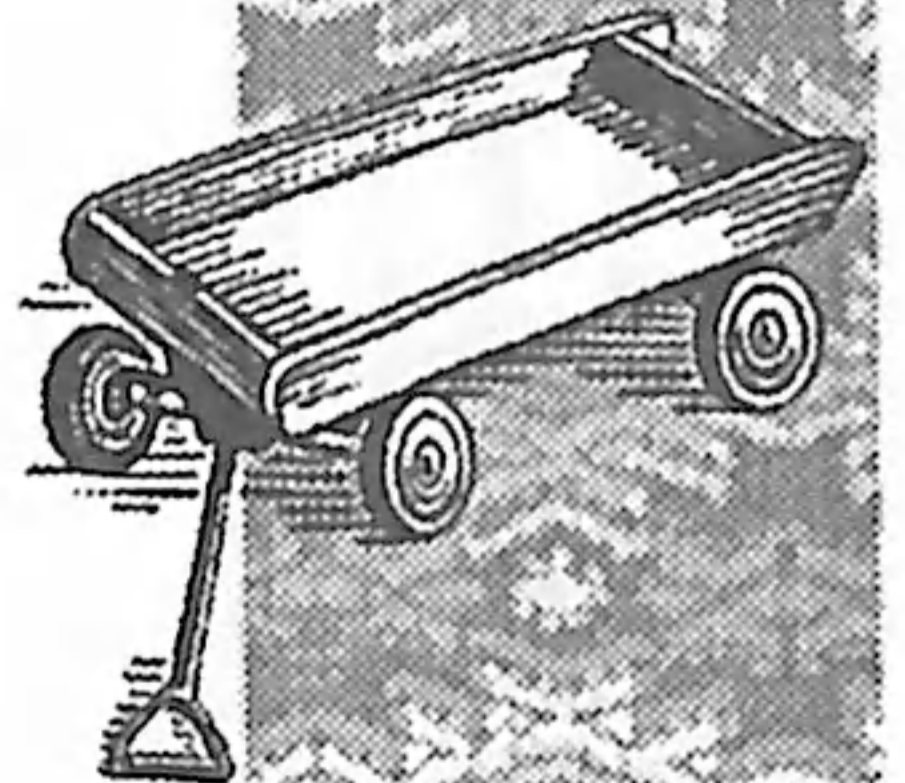
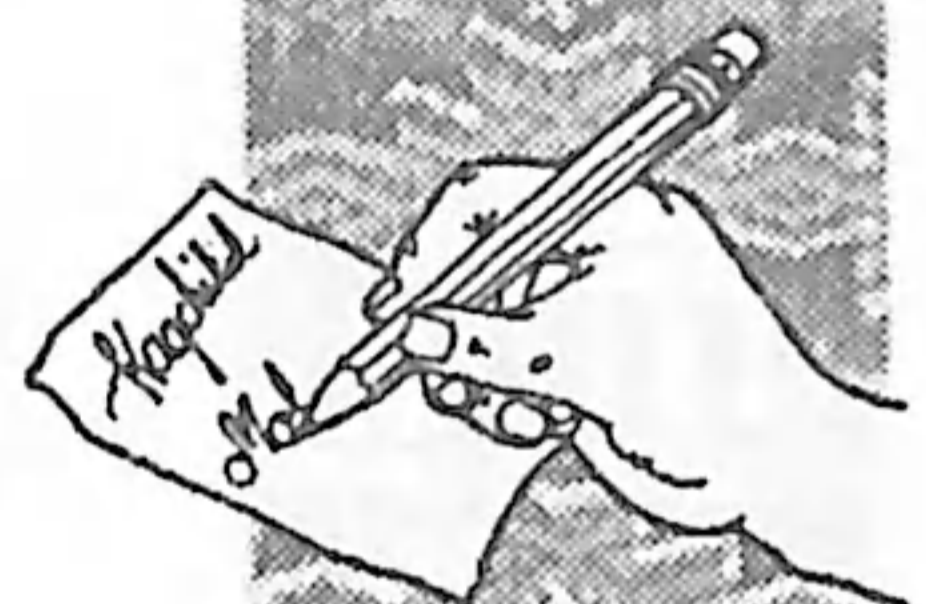

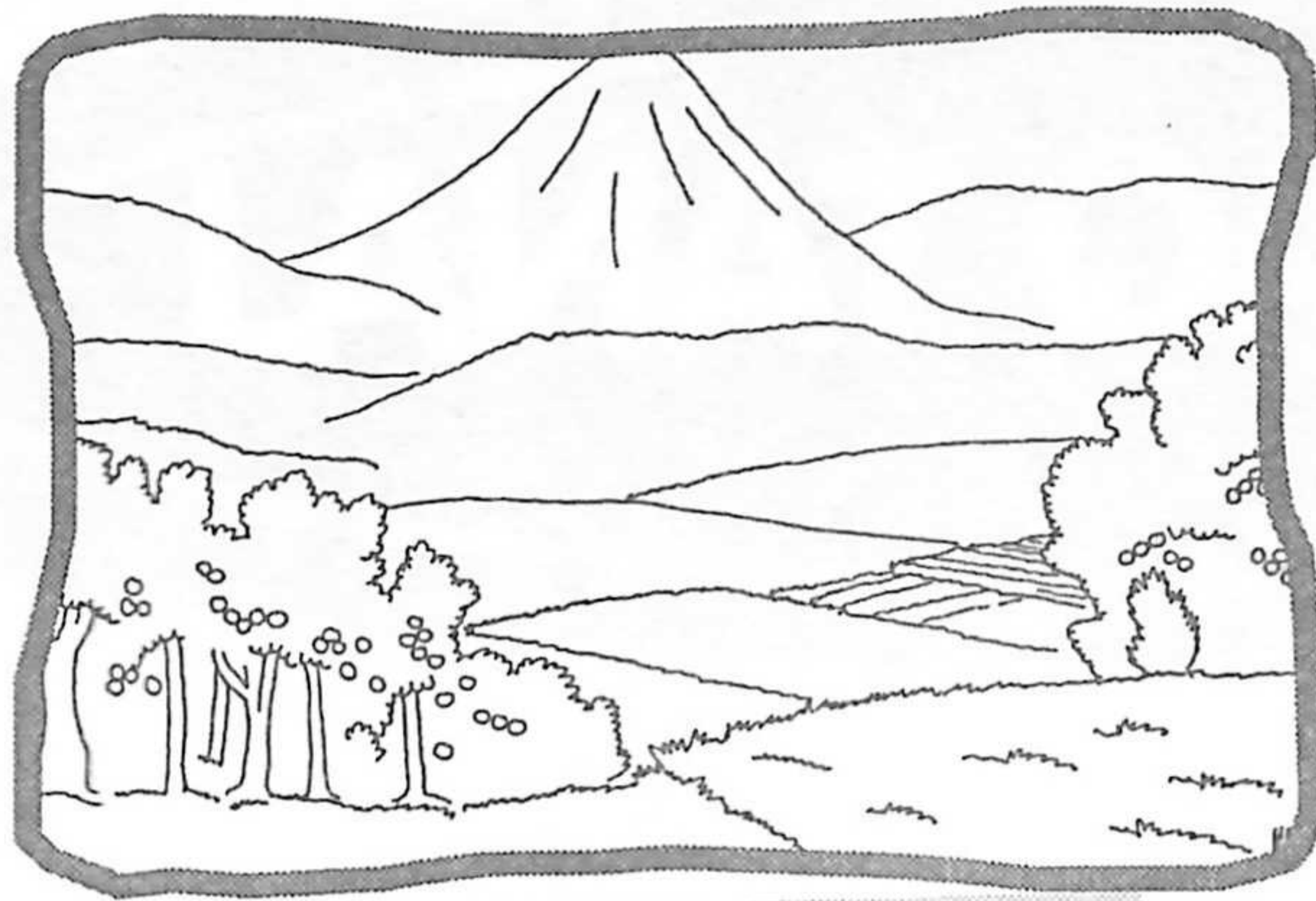

Saq'ij

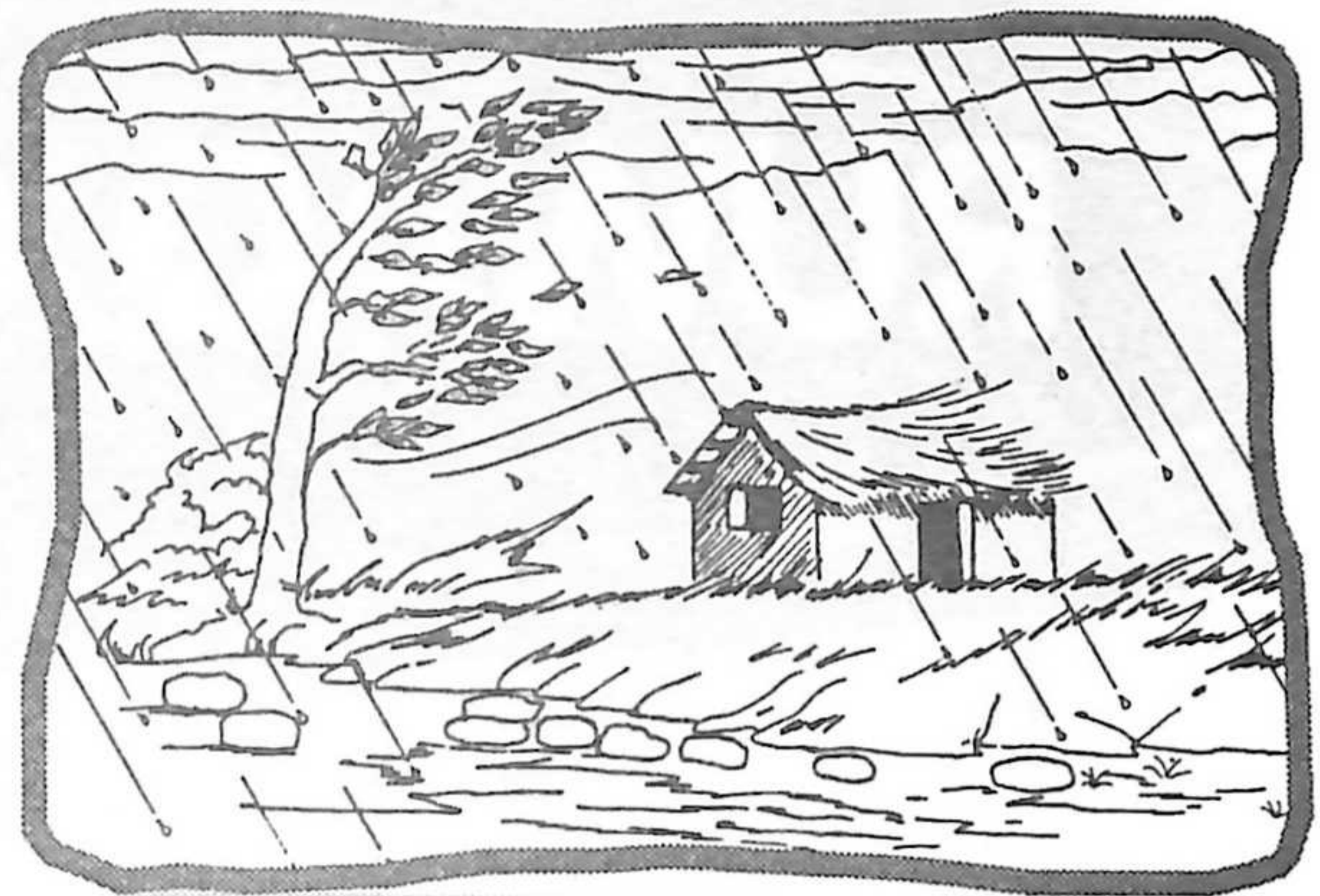

jäb'

# Ri q'ijul

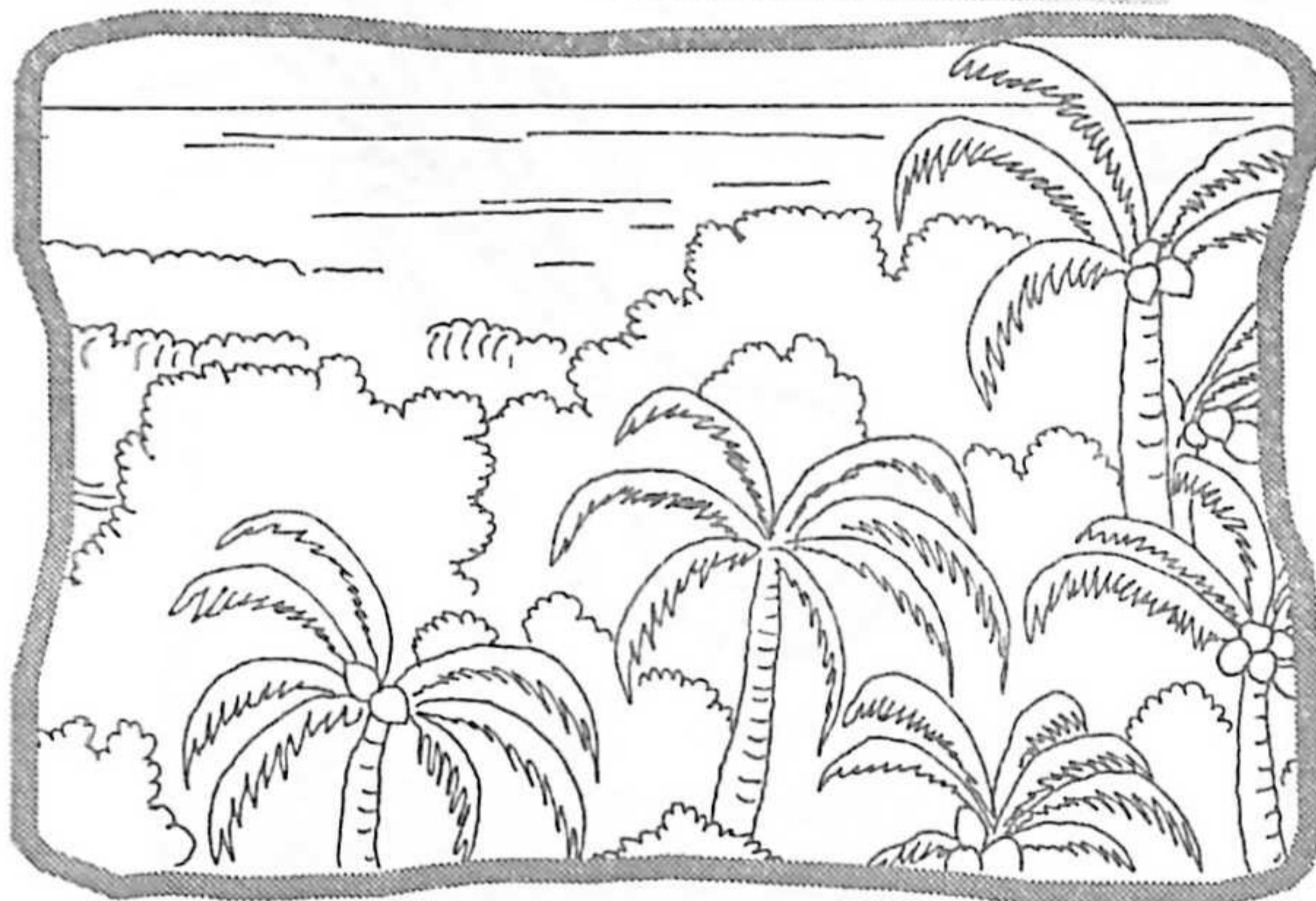

k'atän

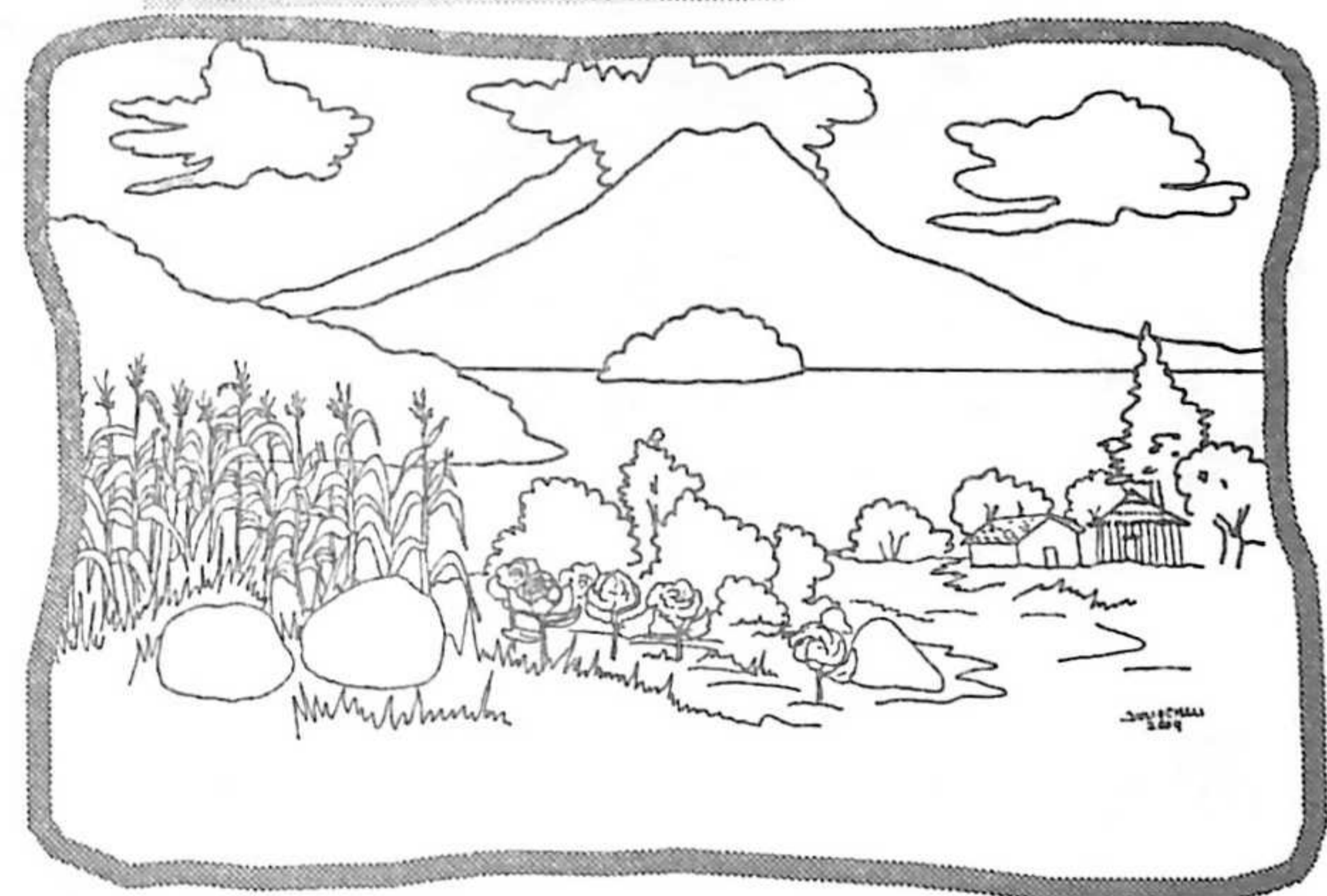

tew

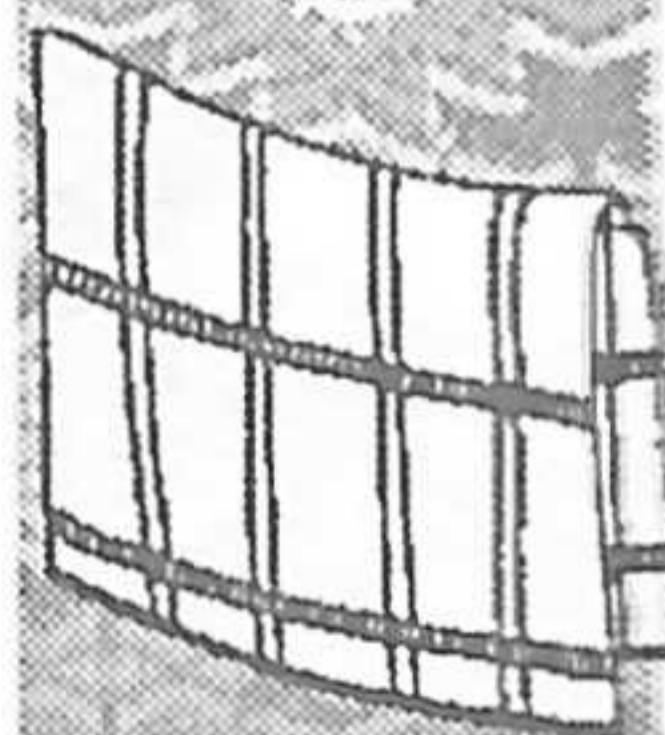
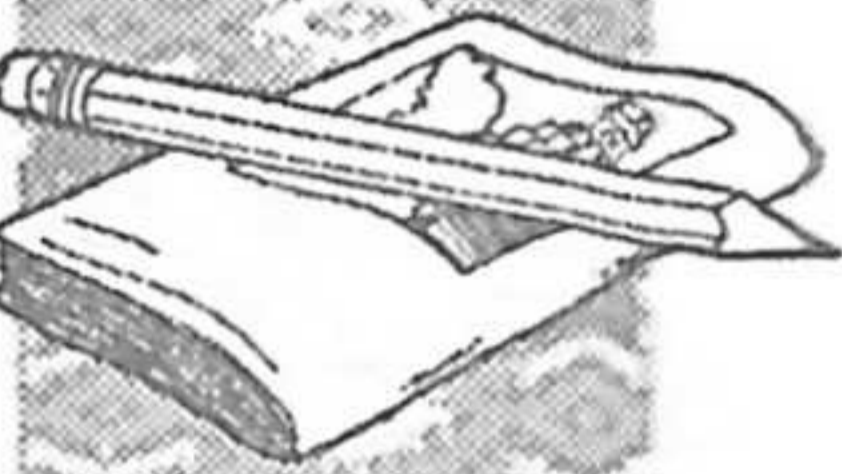

Pa kajkäj tqacholajij kib'i' ri ruwäch tiko'n ri e k'o töq saq'ij chuqa' töq k'o jäb'.

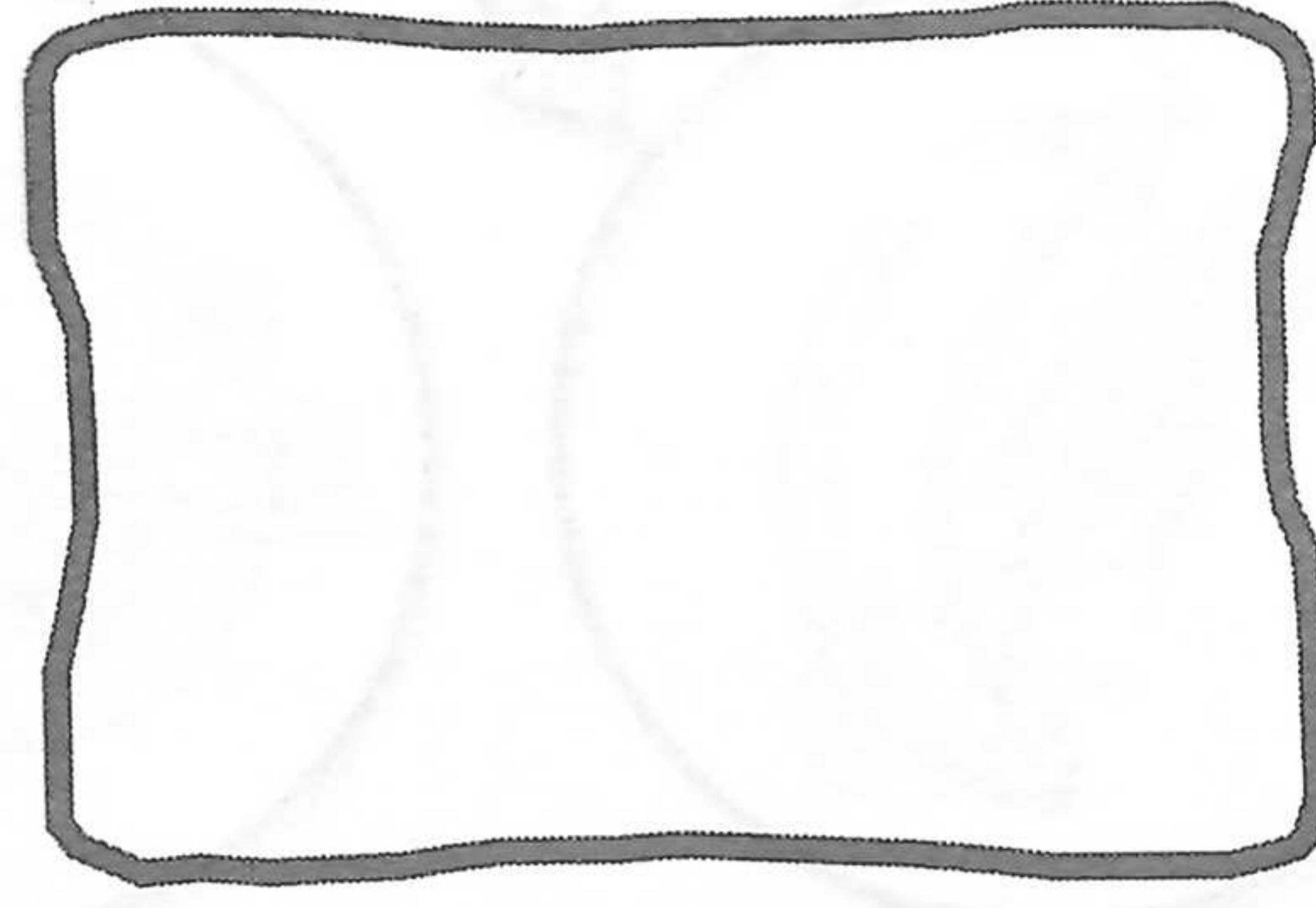
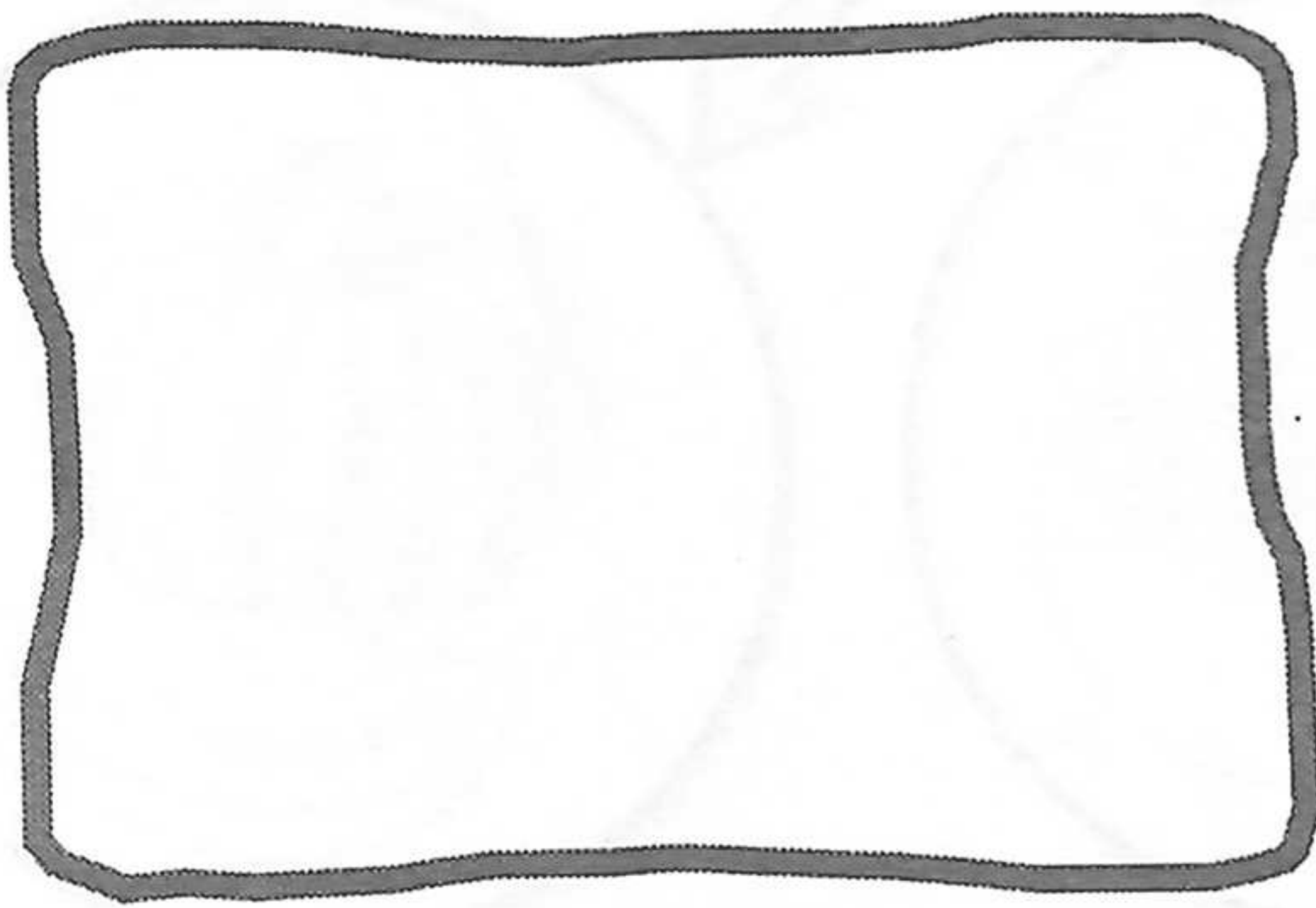
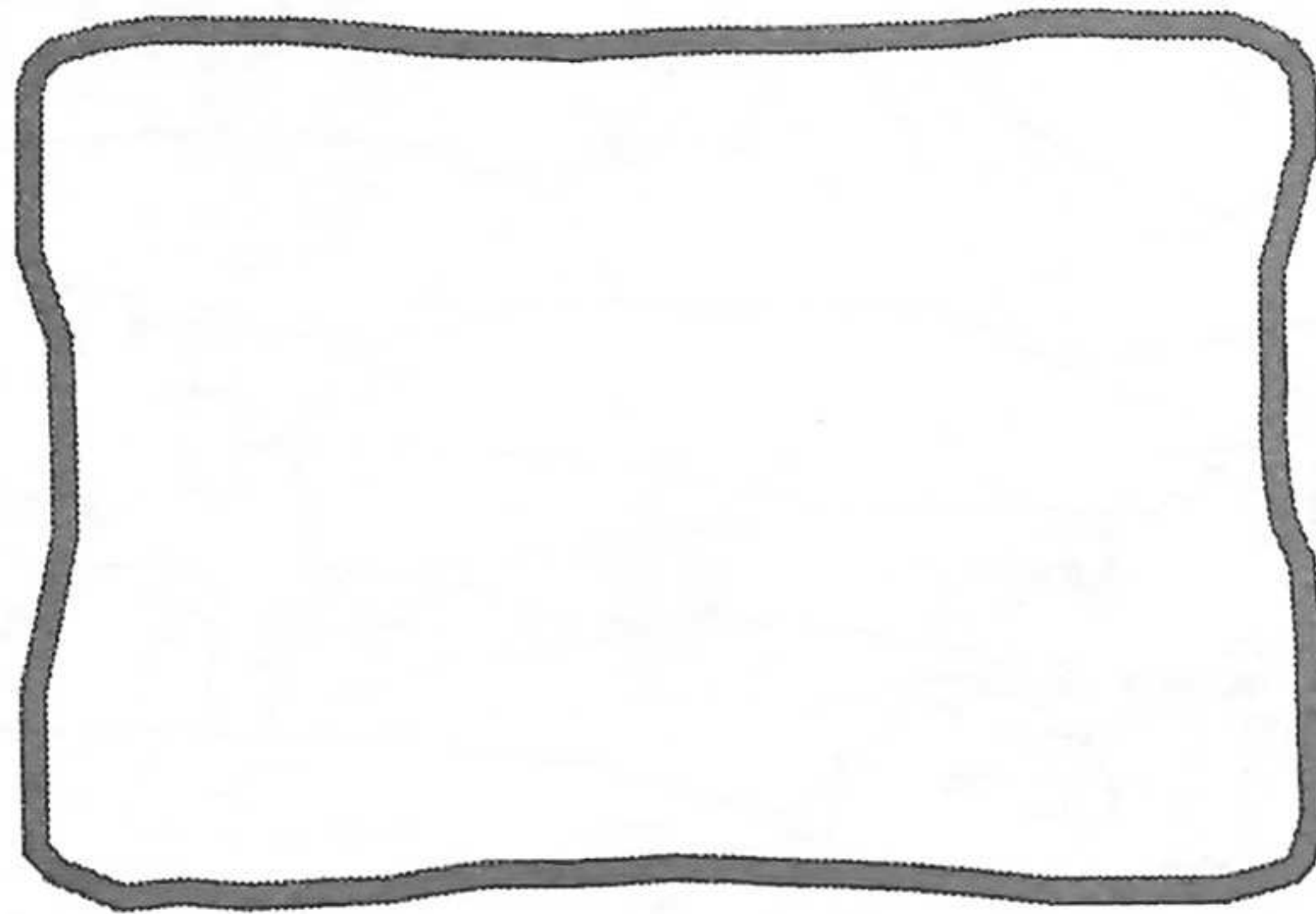
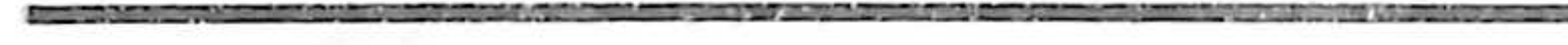
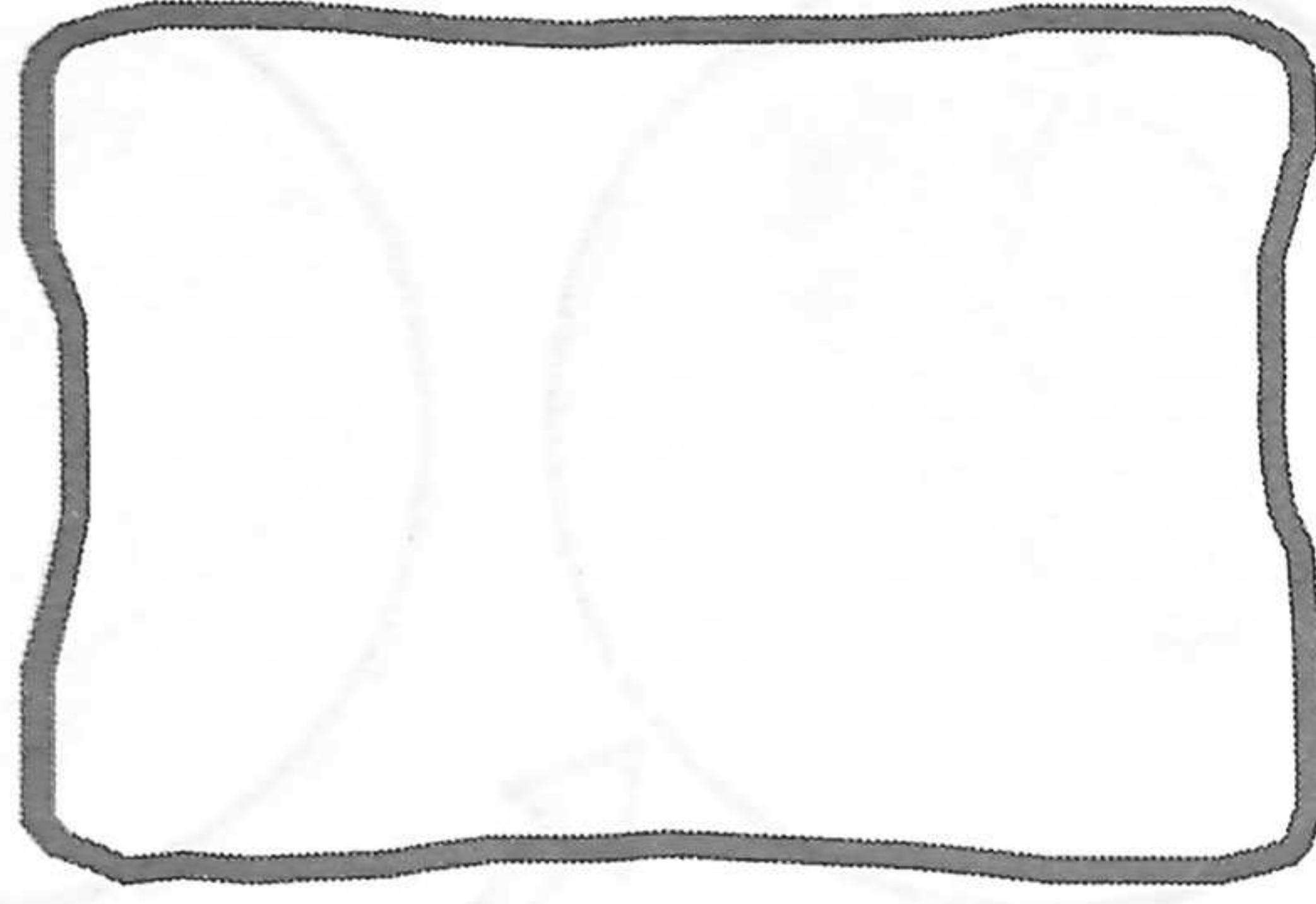
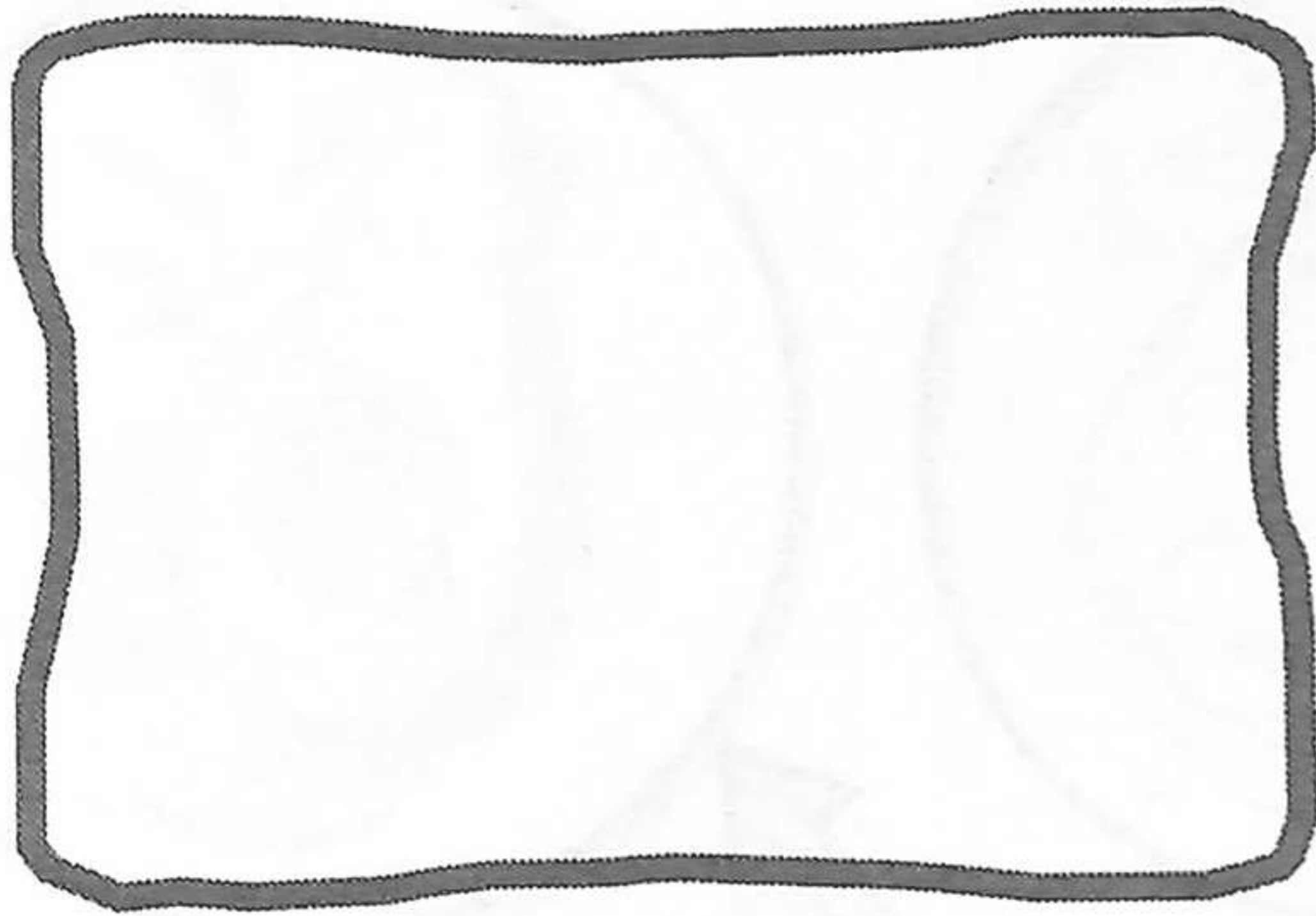

Ri tijoxela' tkiqupij taq achib'al richin nkitz'arab'a' pa taq kajtz'uk, pa ruwi' ri juch' tkitz'ib'aj kib'i'.

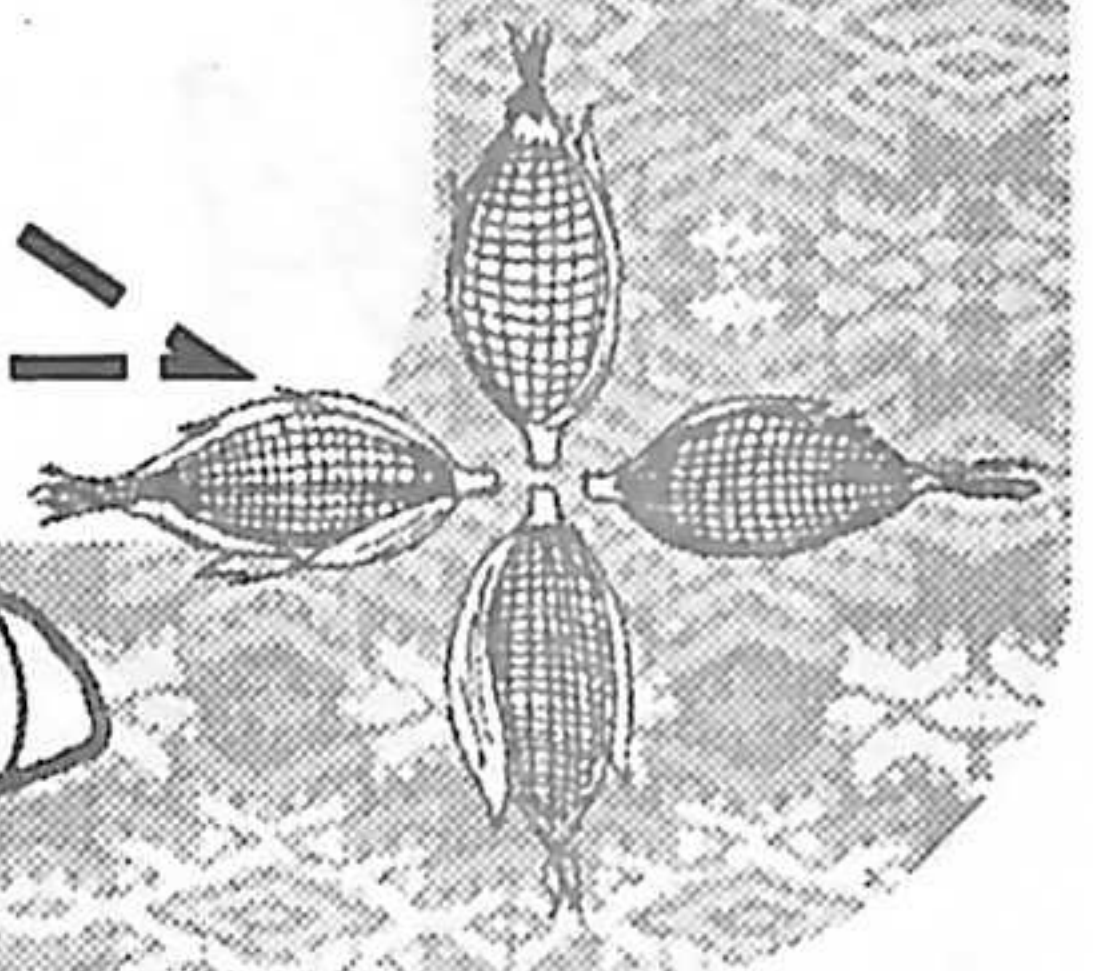
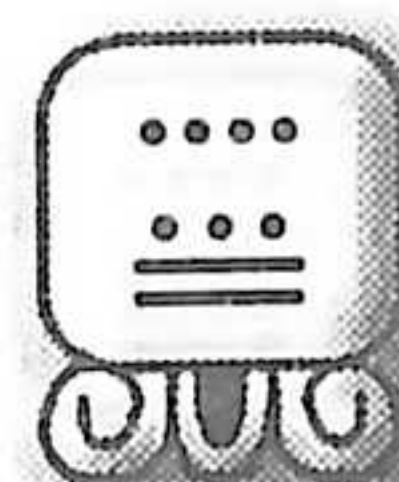

# Ri jiq'ob'äl pa saq'ij



Raxtzuy

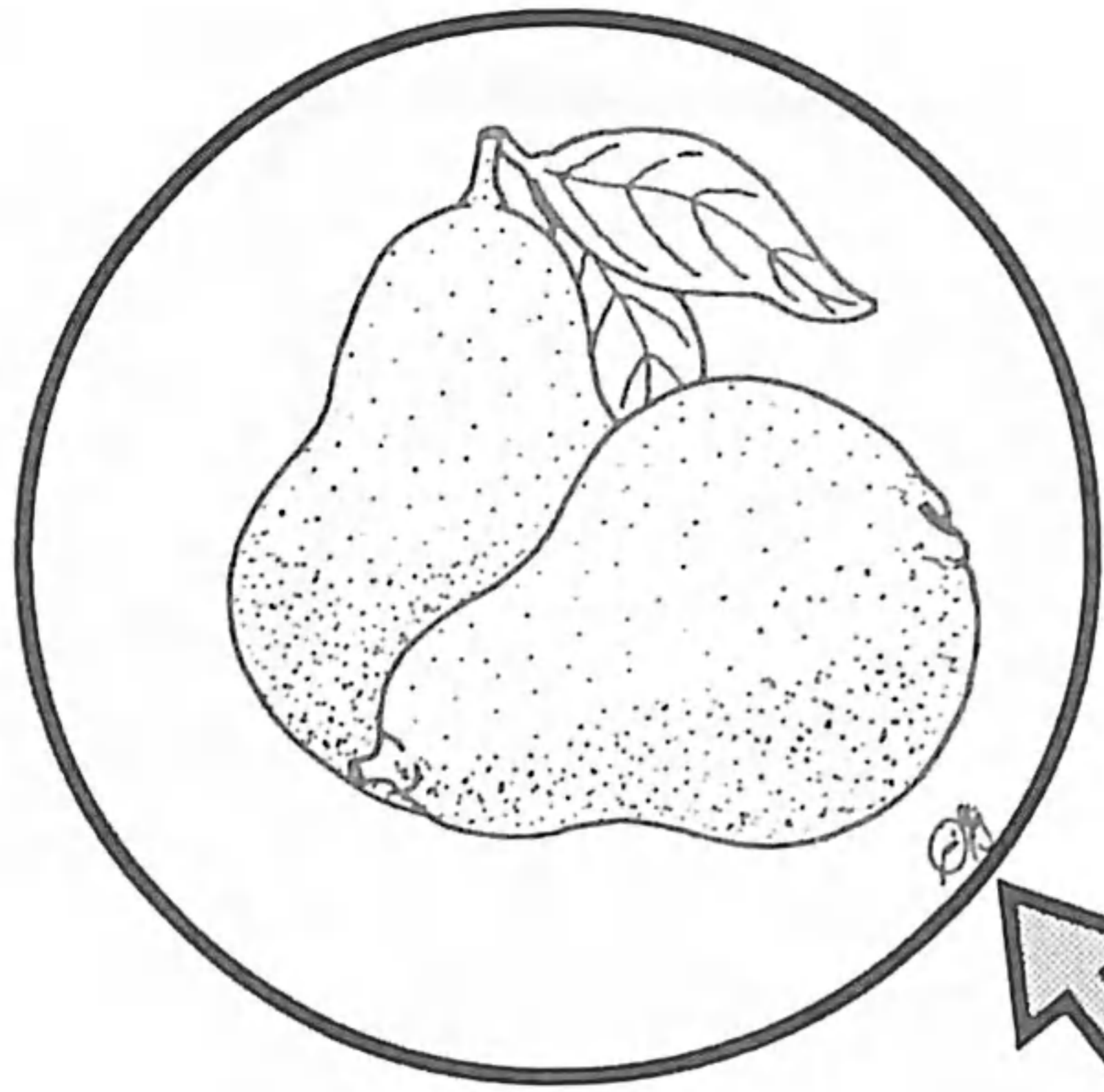

Tulül

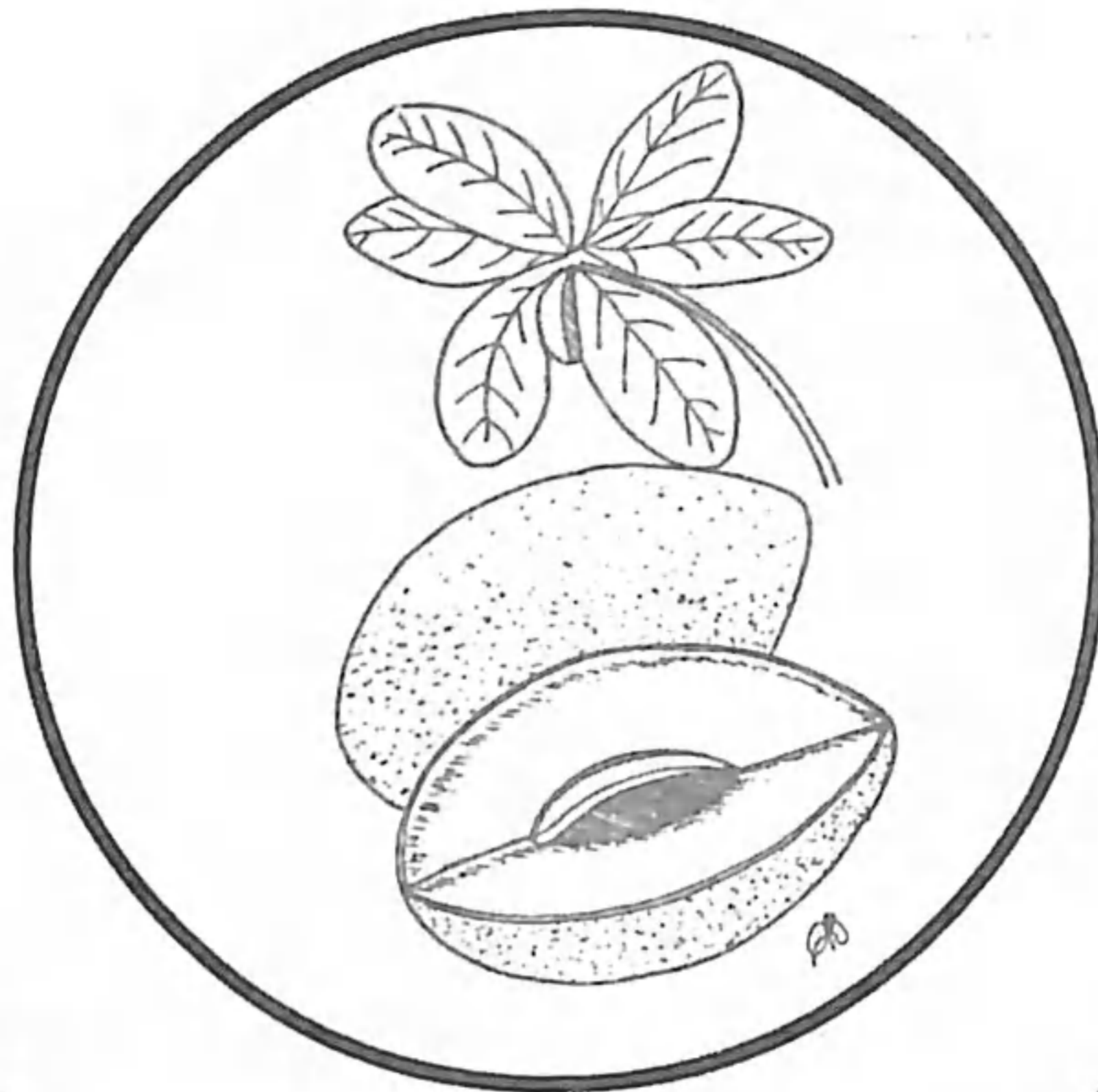

Ch'öp

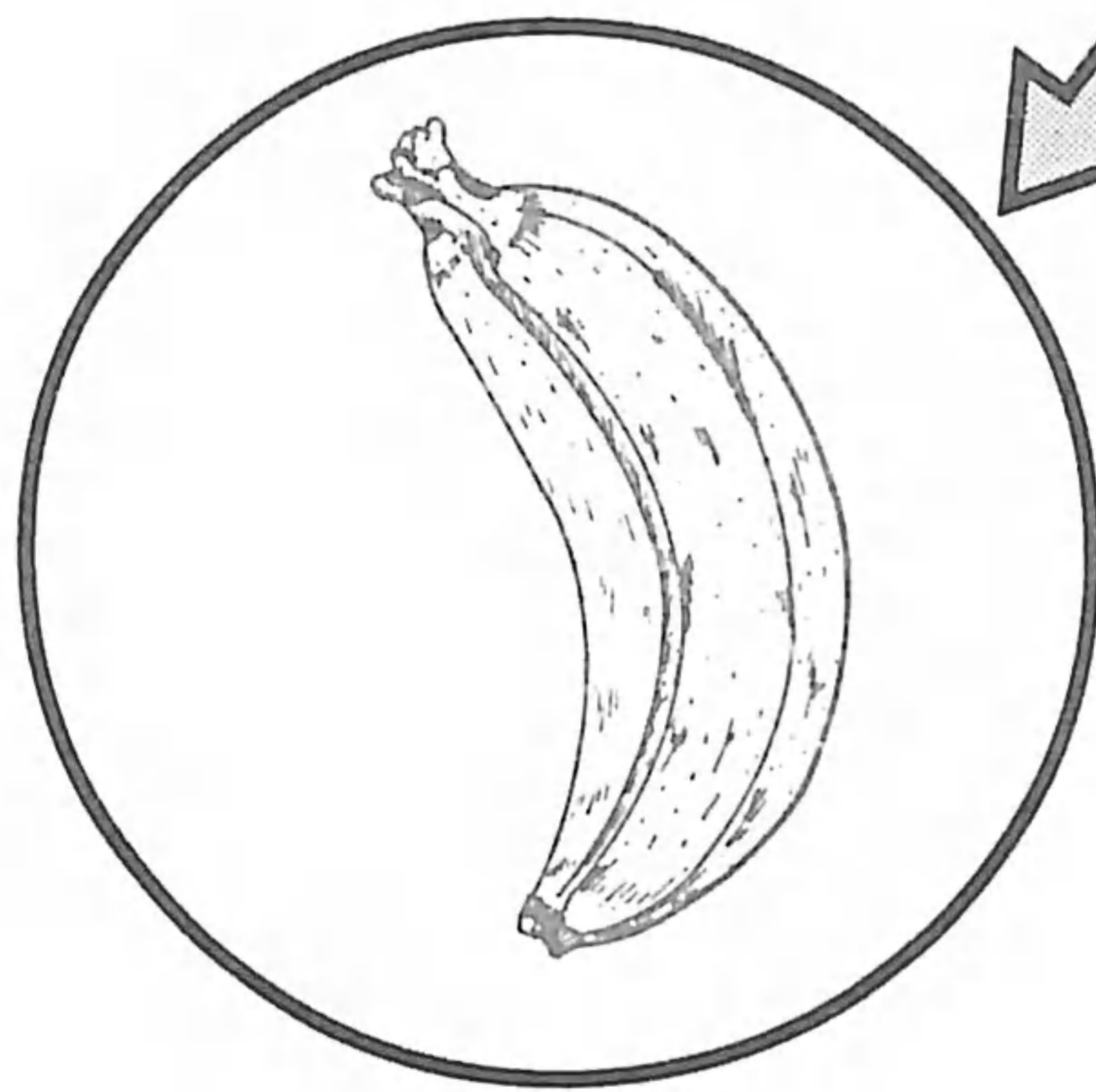
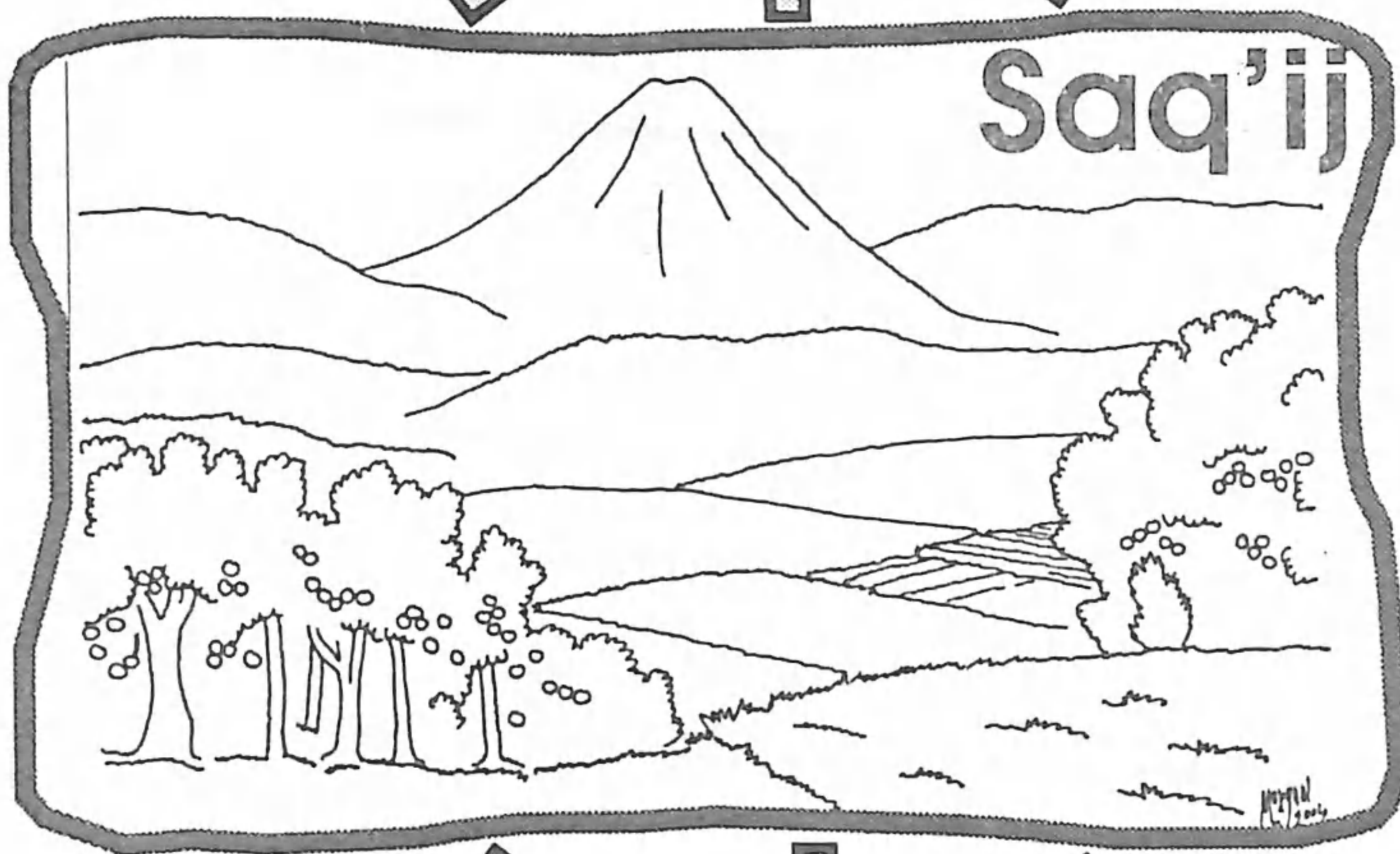
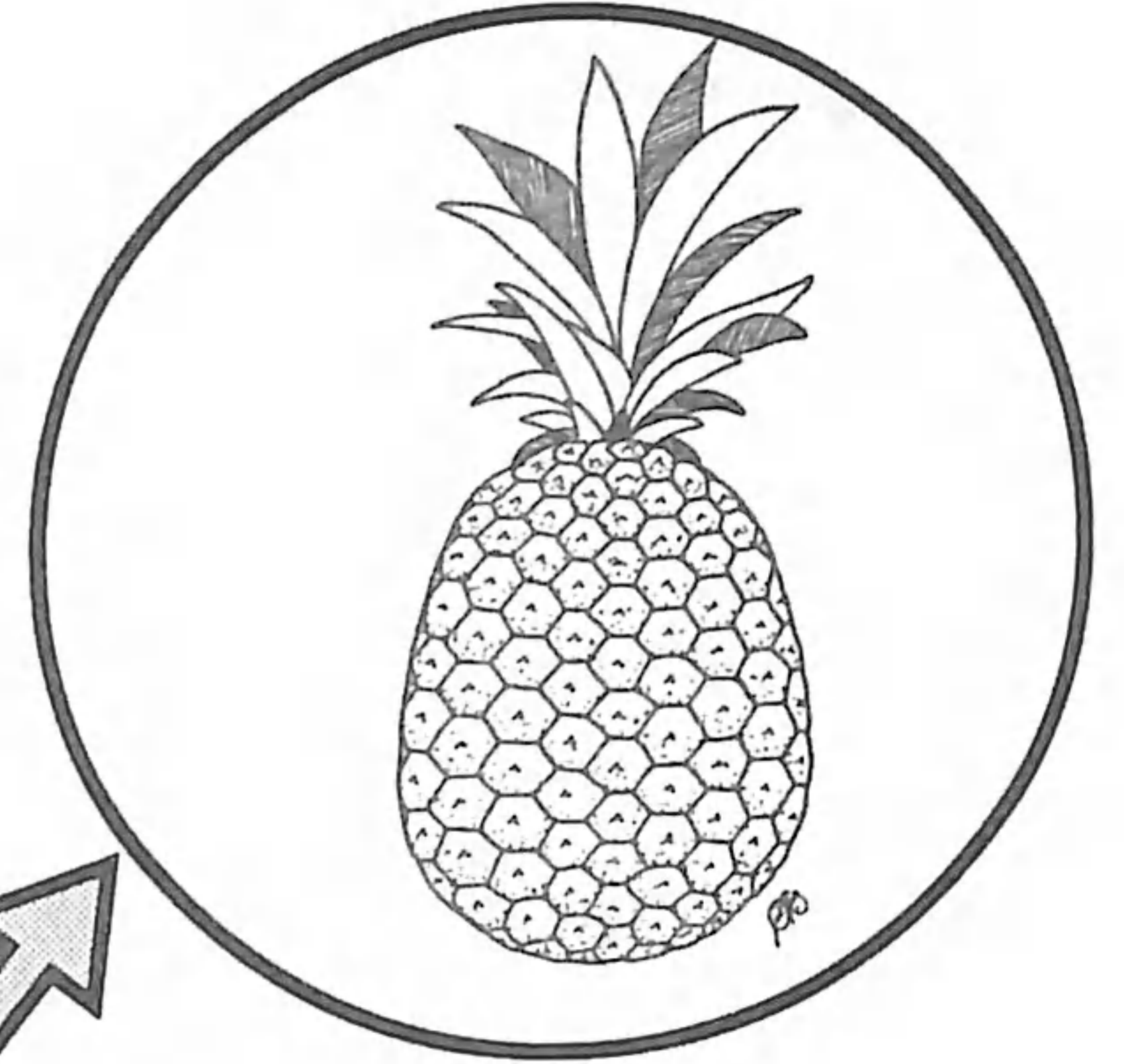

Nimasaq'ul

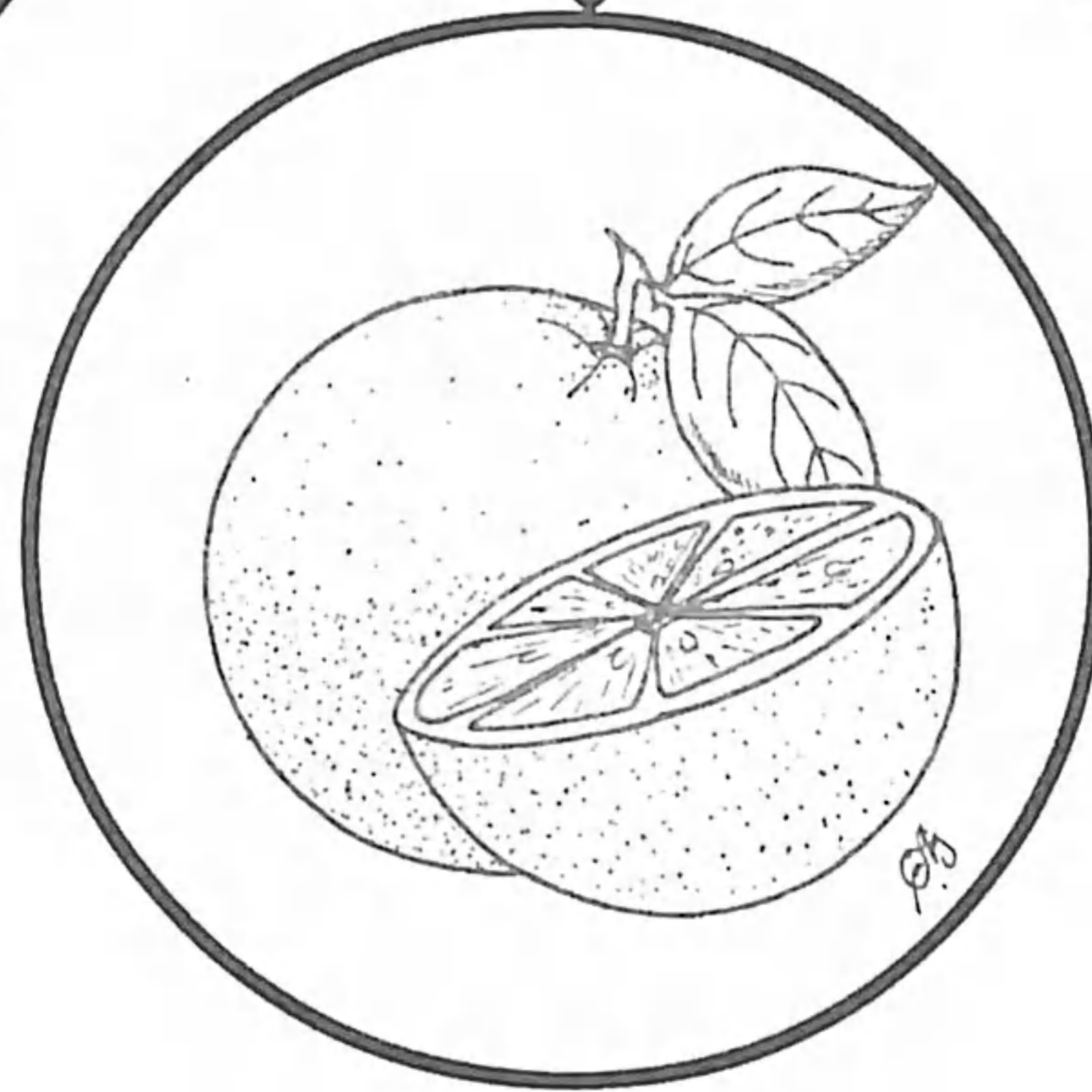

Alanx

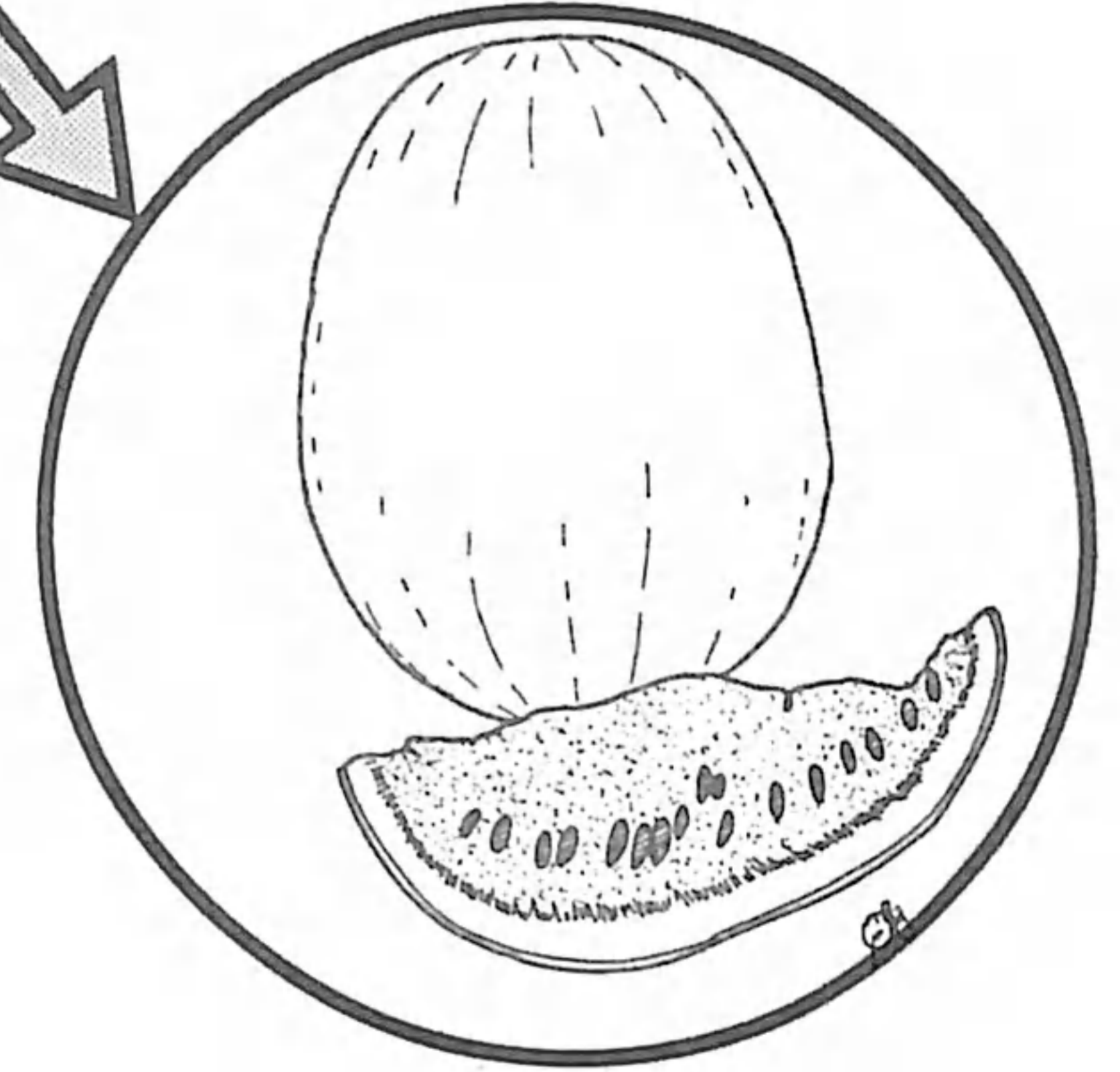

Kaqaq'oq'

Ri tijoxela' tkikanoj kachib'äl ch'aqa chik  
jiq'ob'äl ri man k'o ta chupam re achib'äl re'.

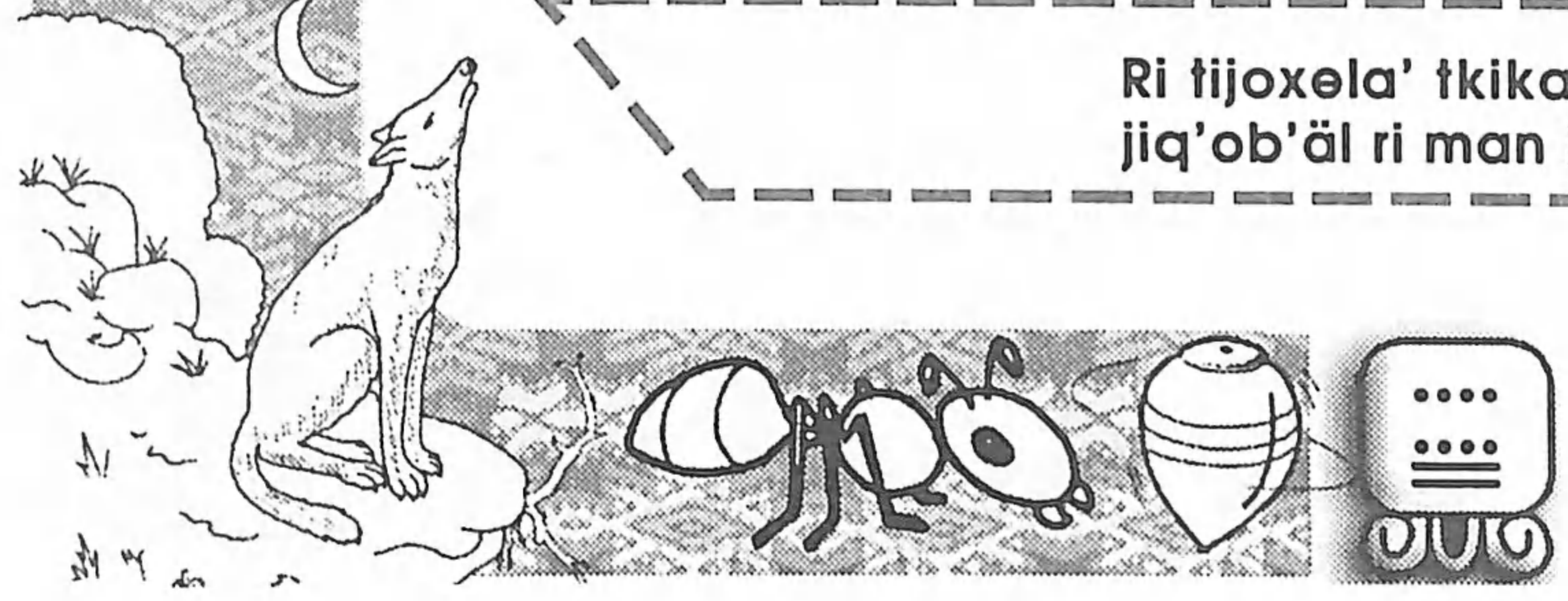
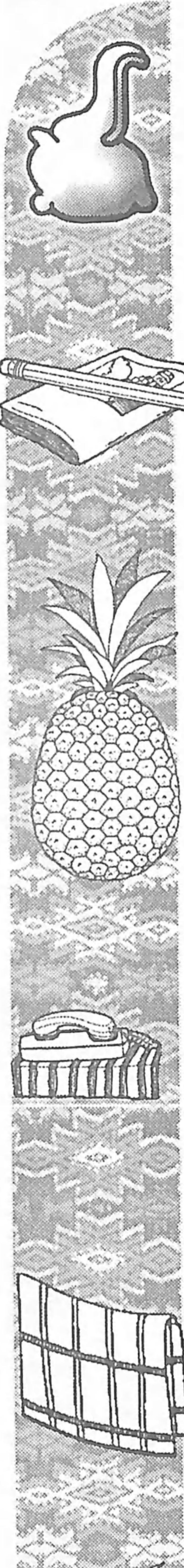

# Ri ruwäch ichaj pa jäb'

Oj

Saqwäch

Ik

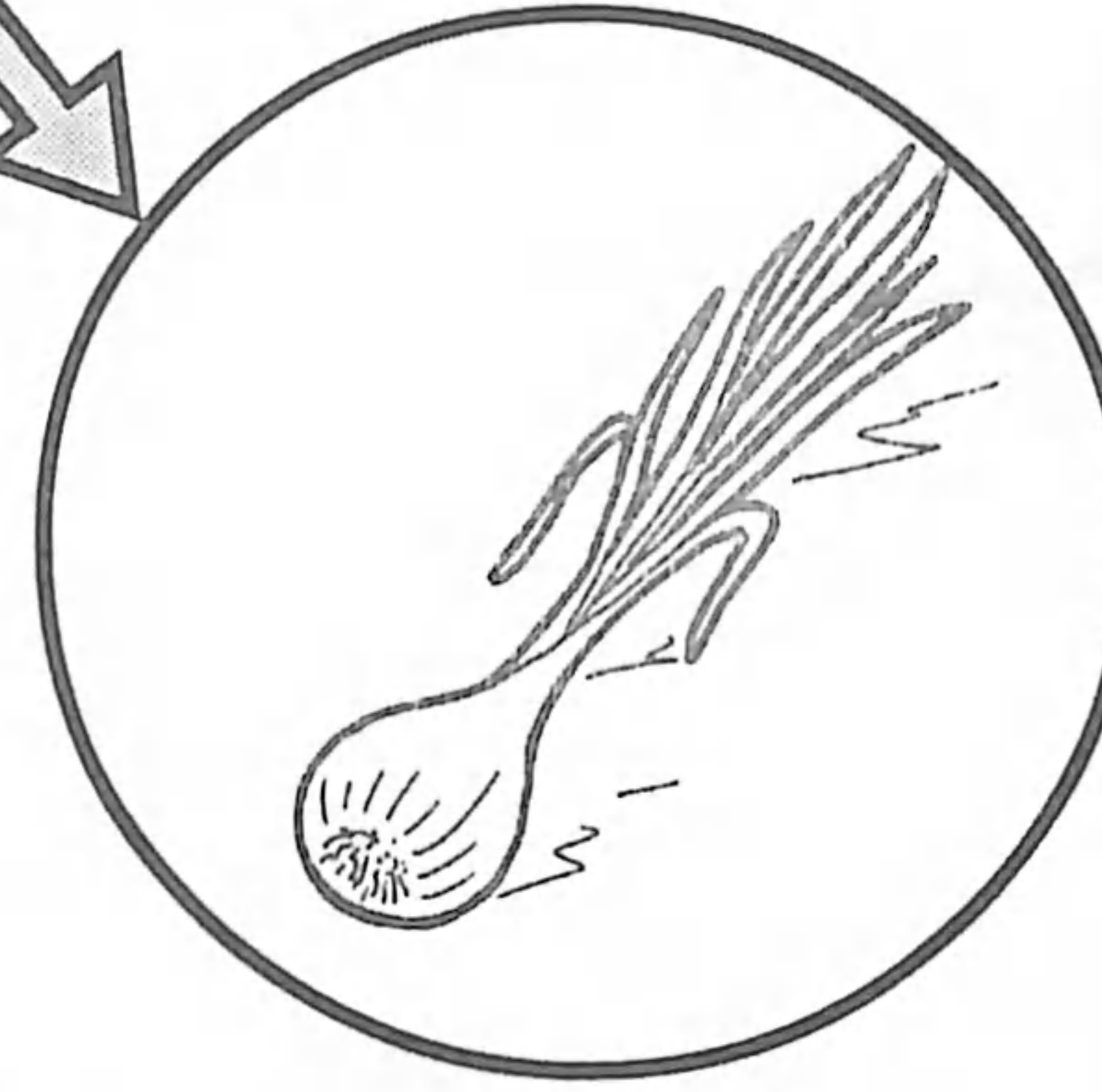
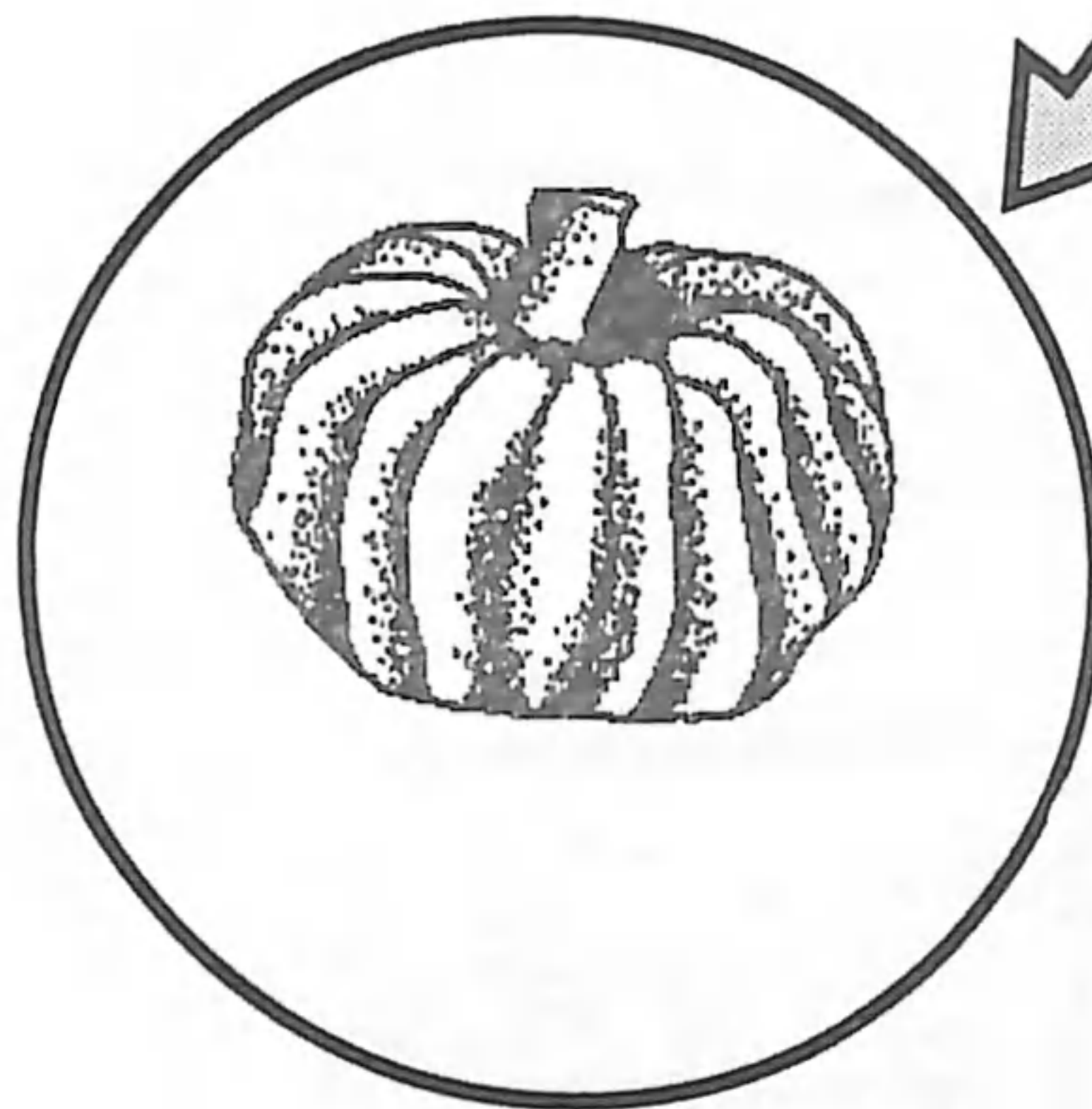
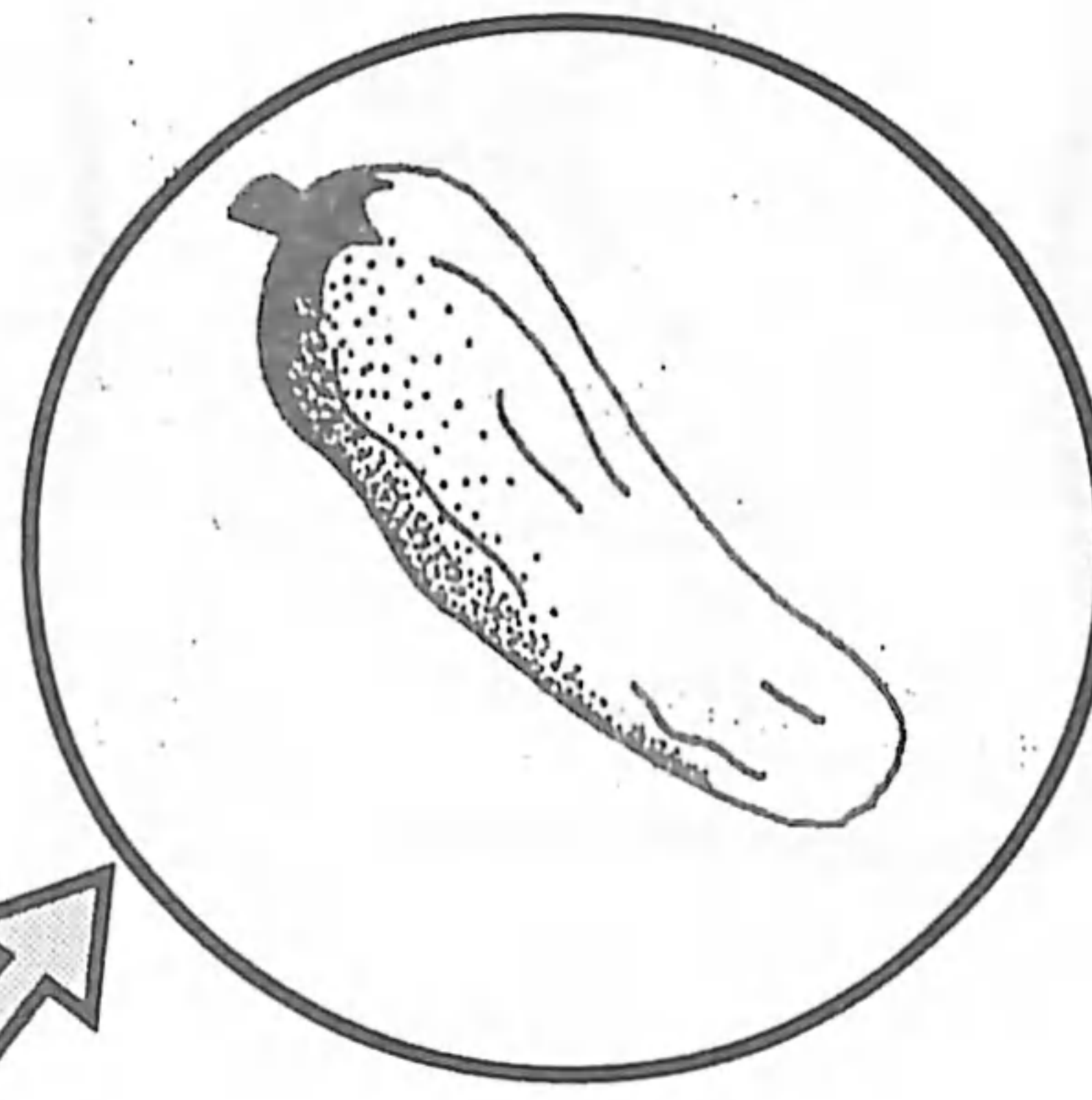
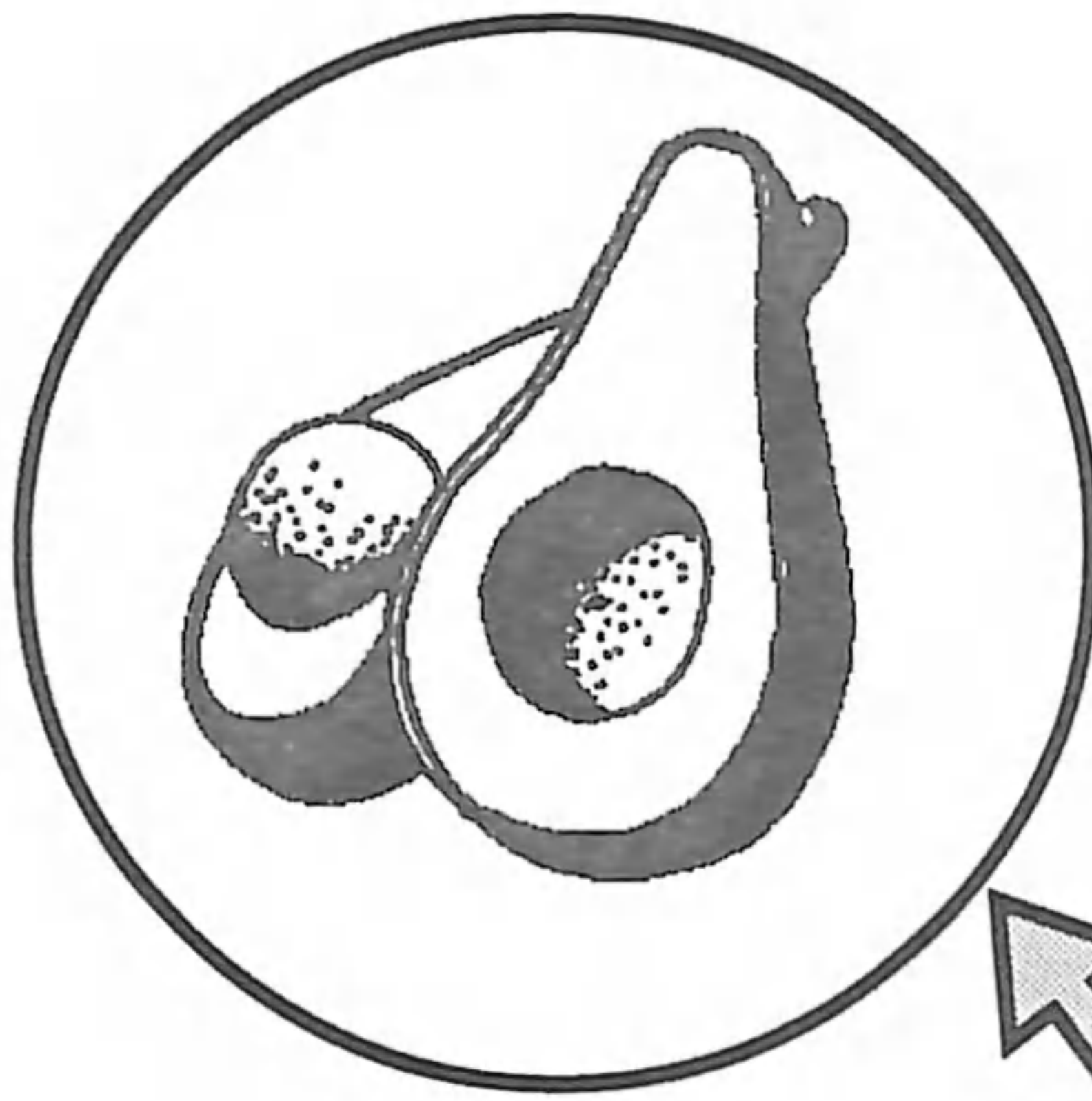

Ik'oy

Kotz'i'ichaj

Xnakät

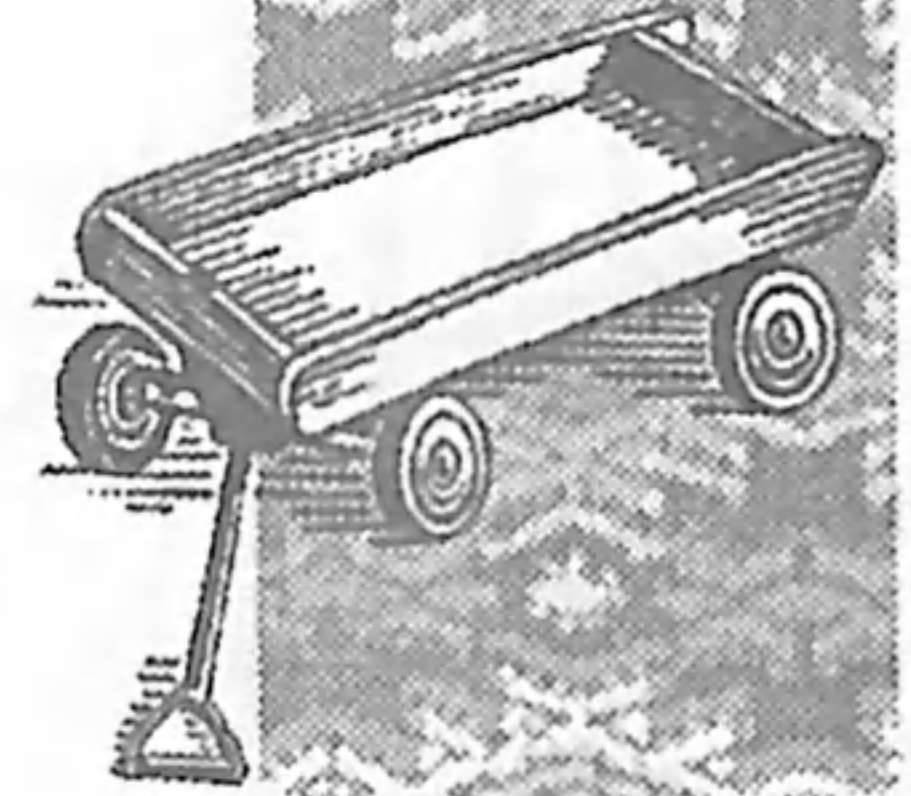
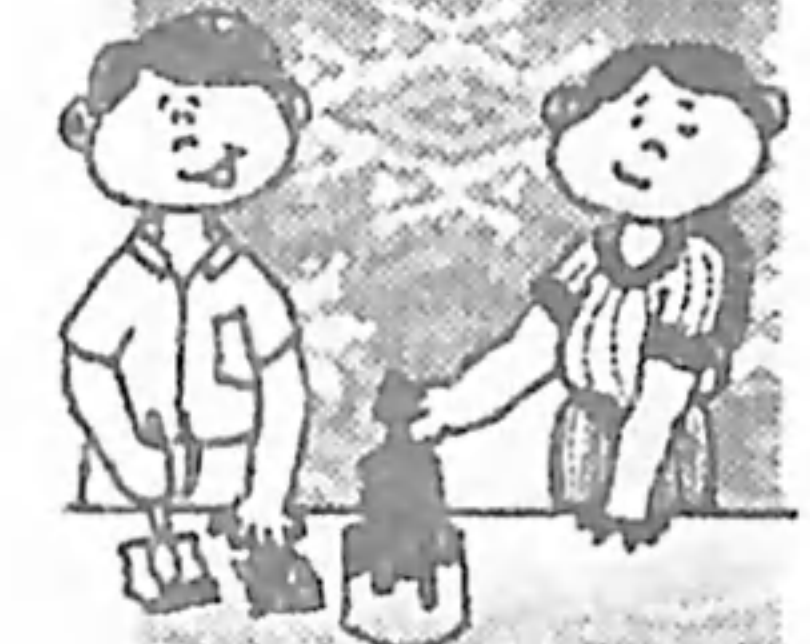
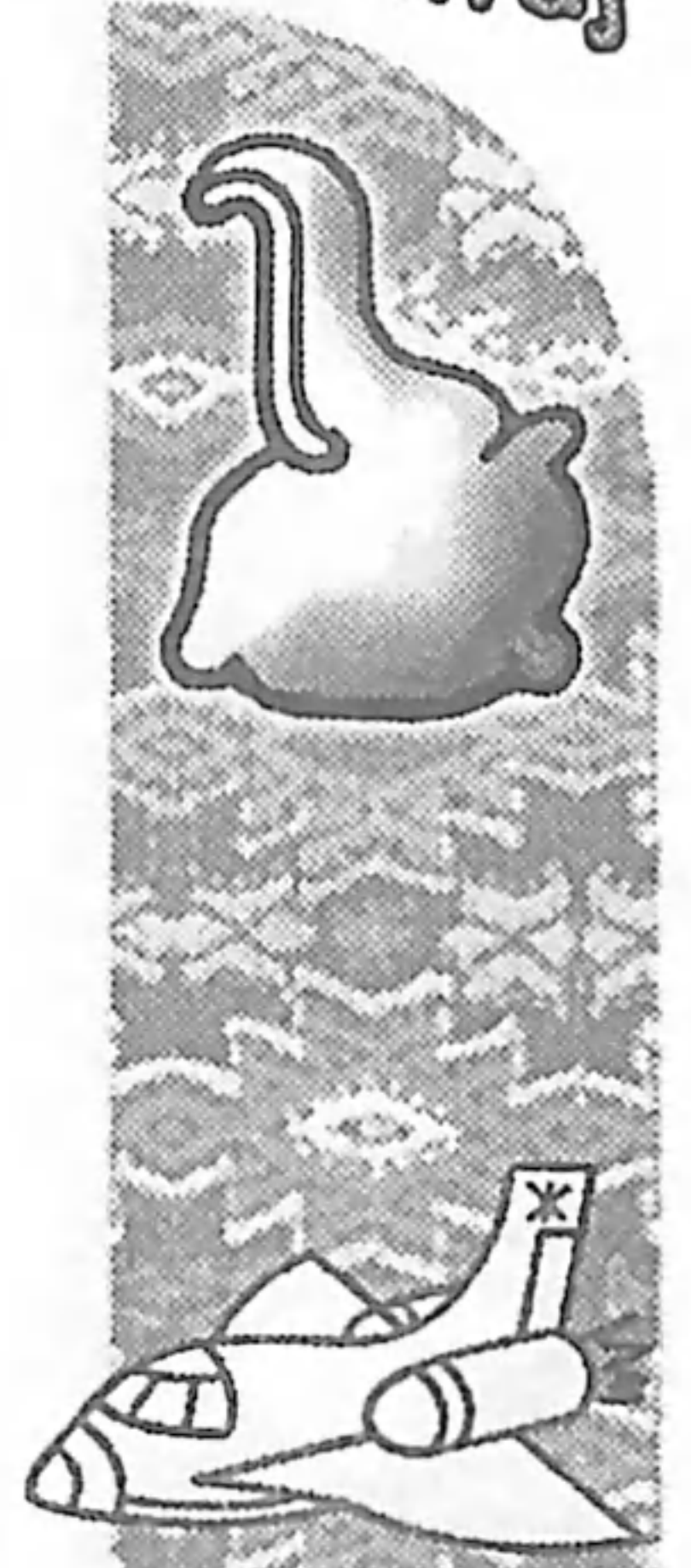

Ri tijoxela' tkikanoj kachib'äl ch'äqa chik jiq'ob'äl ri man k'o ta chupam re achib'äl re'.

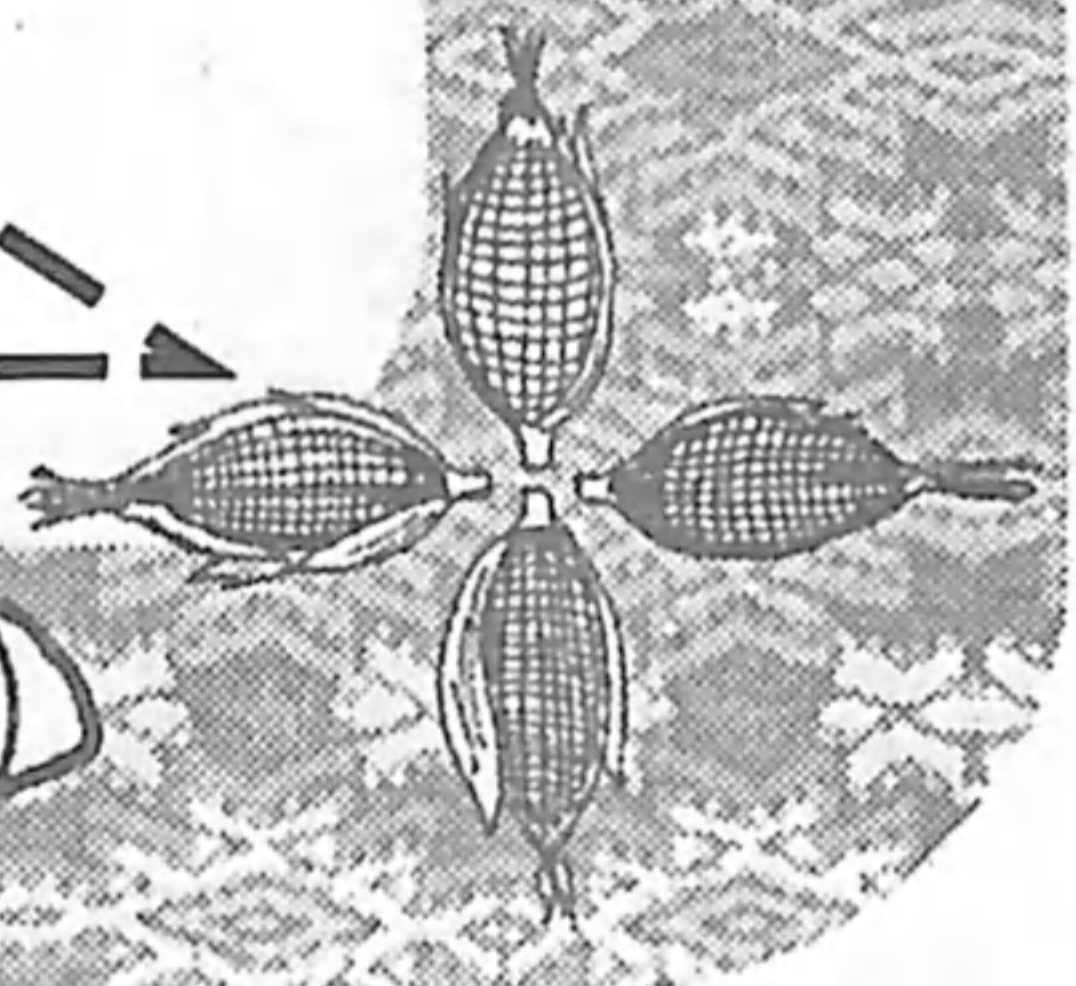
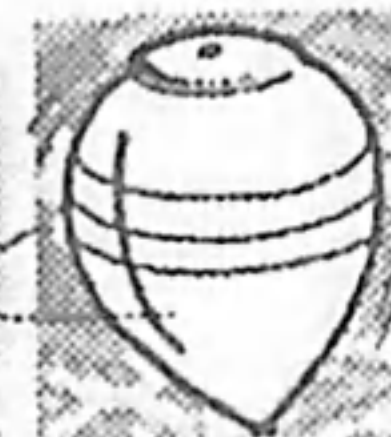



Ri ruwäch che' pa jöb'



Raxtzuy

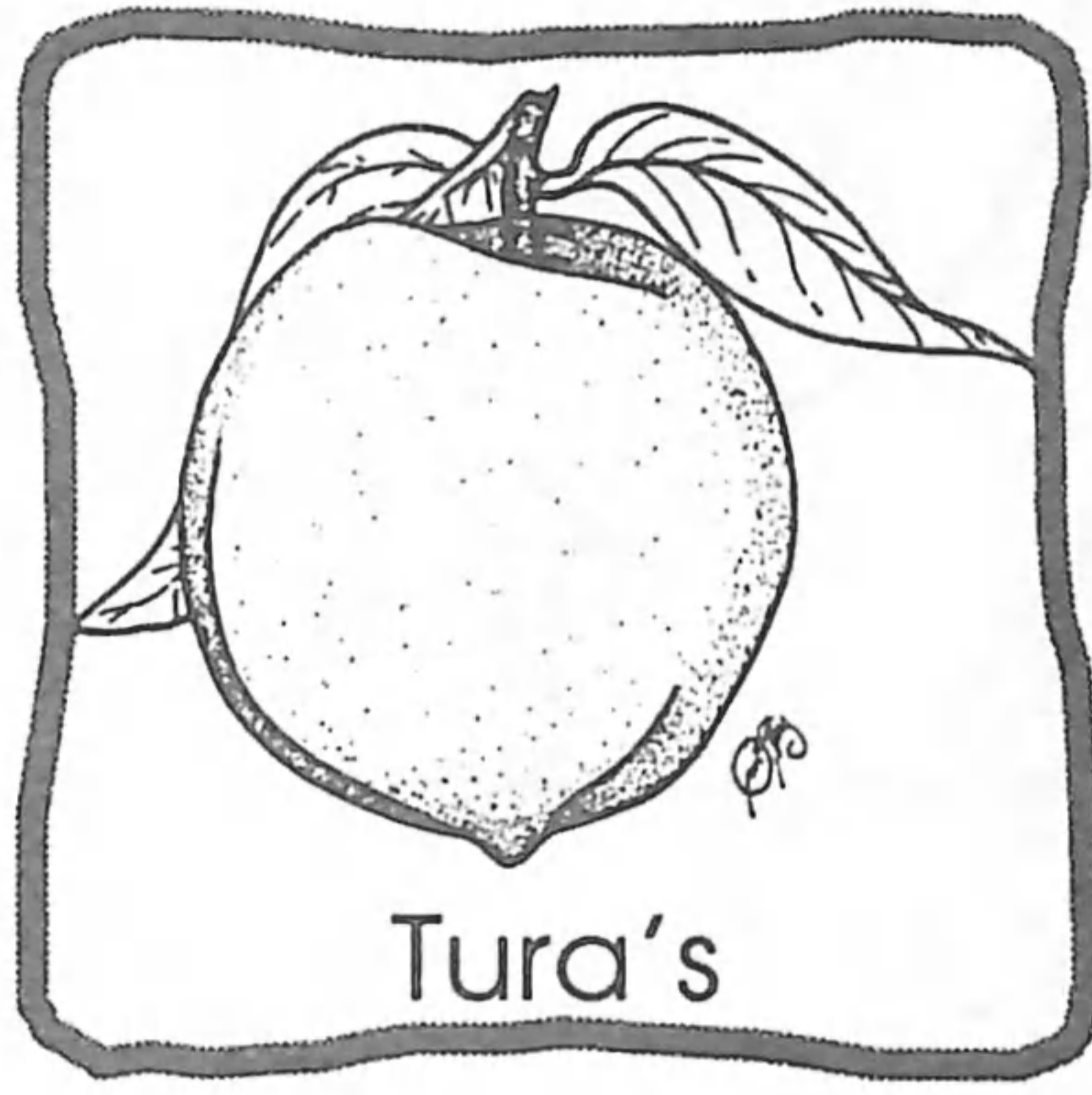

Tura's

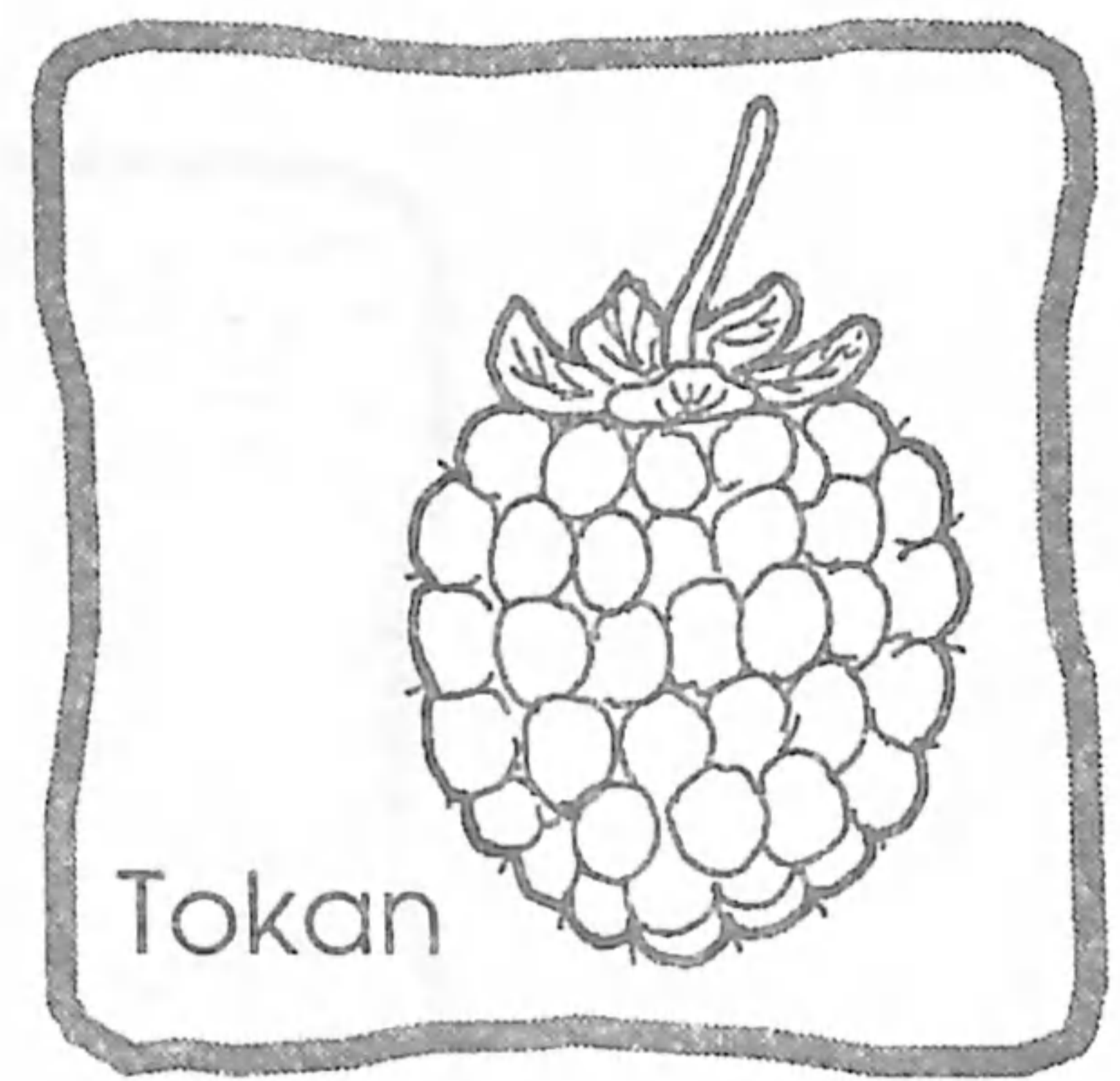

Tokan

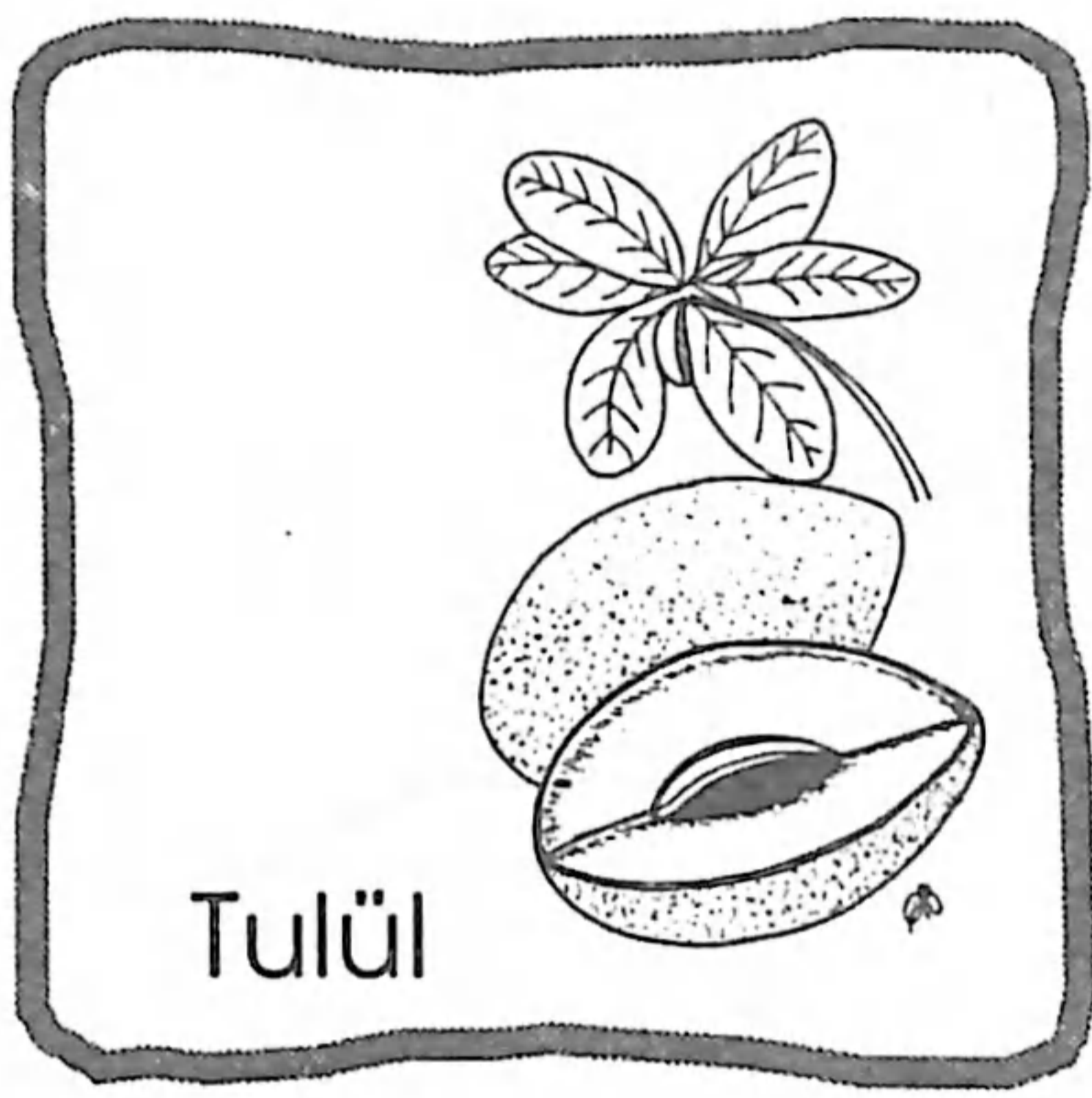

Tulül

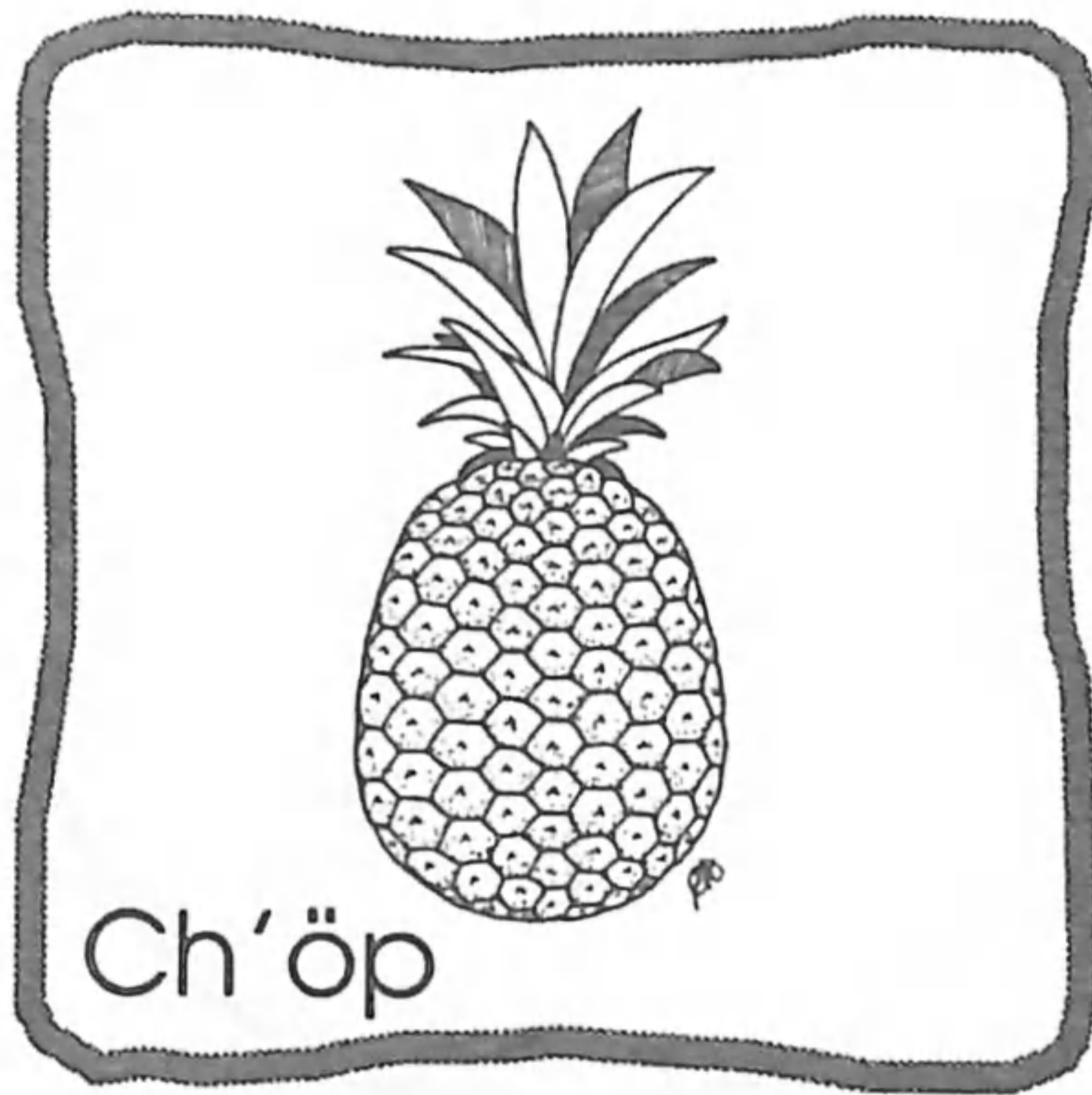

Ch'öp



Alanx

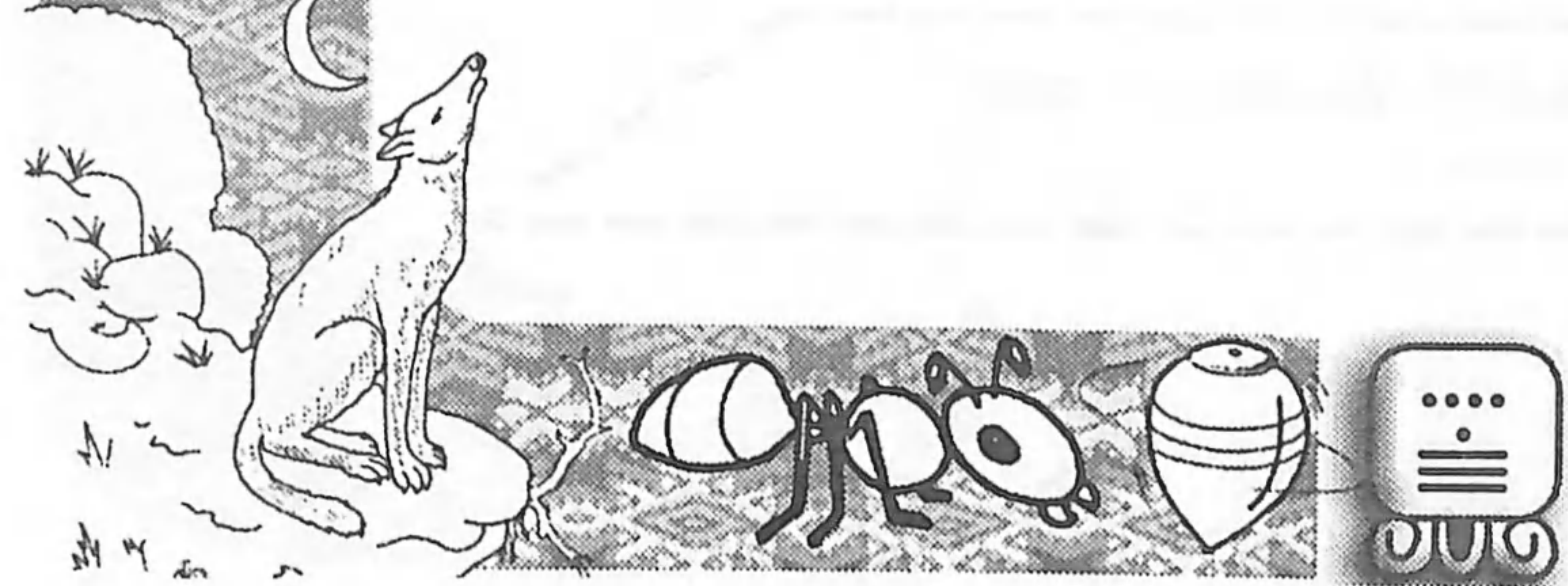
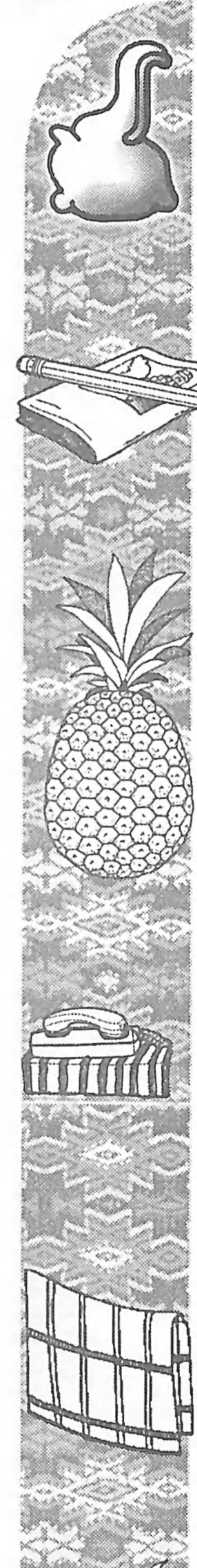

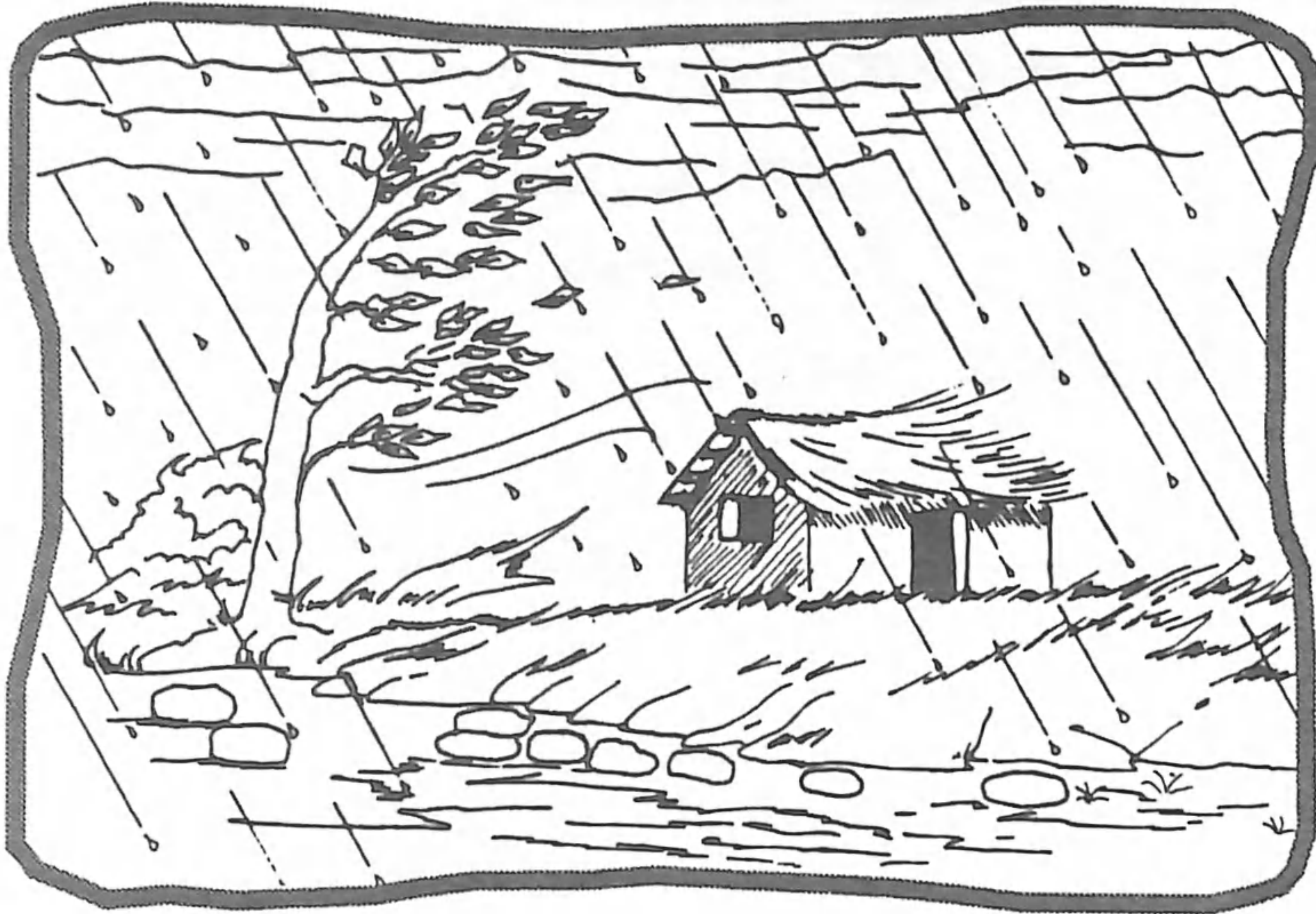

Tew ulew

meq'ën ulew

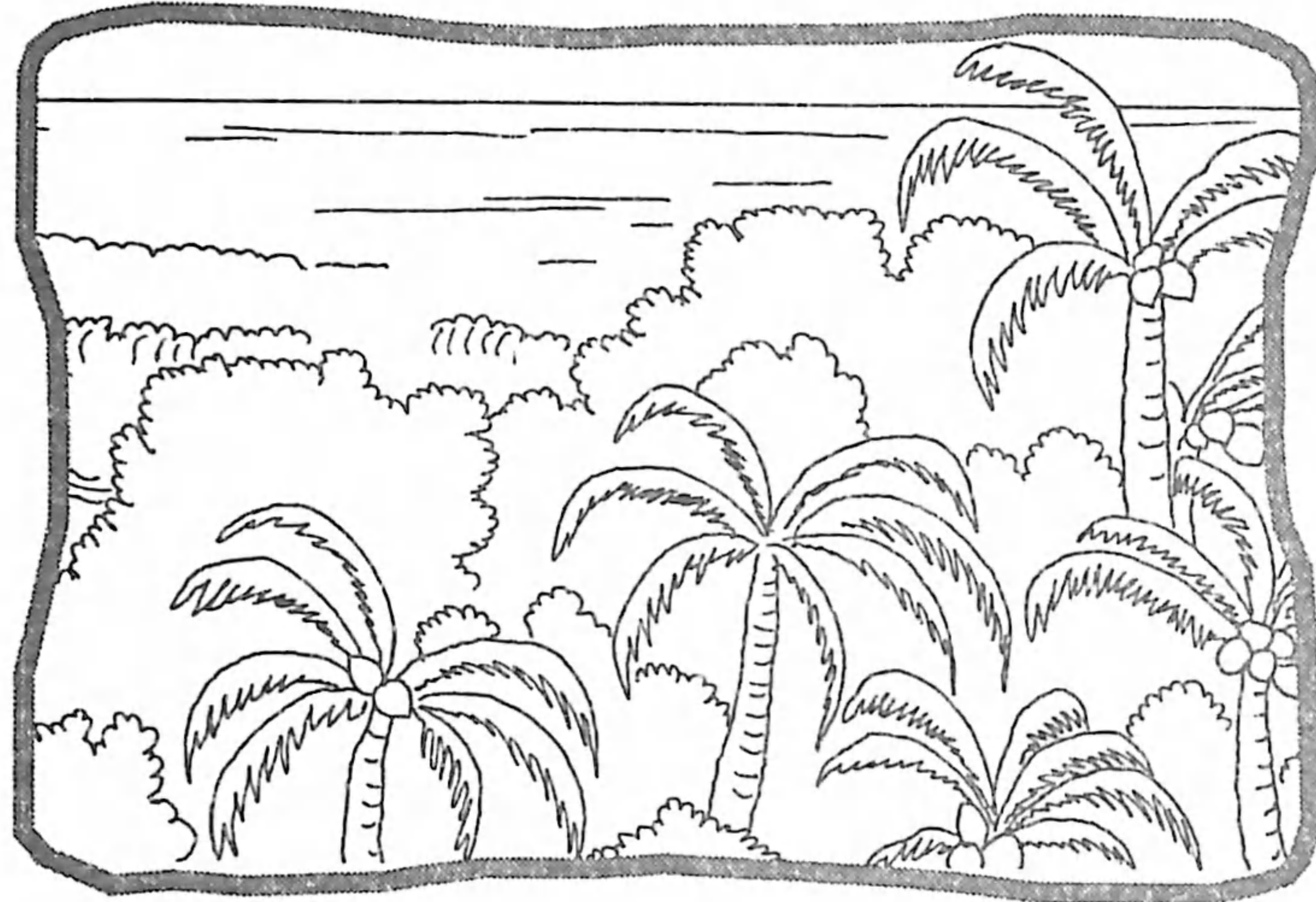

Lilöj ulew

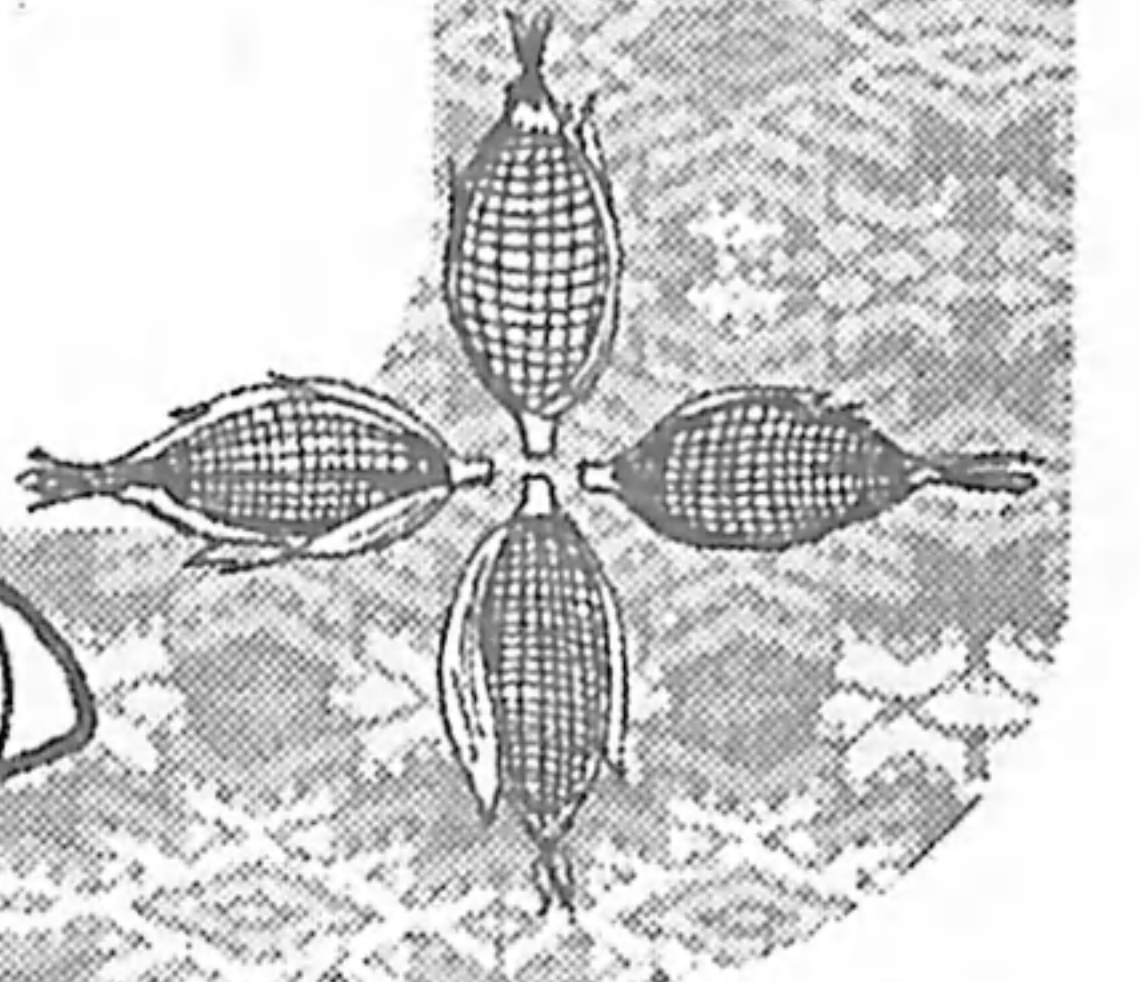
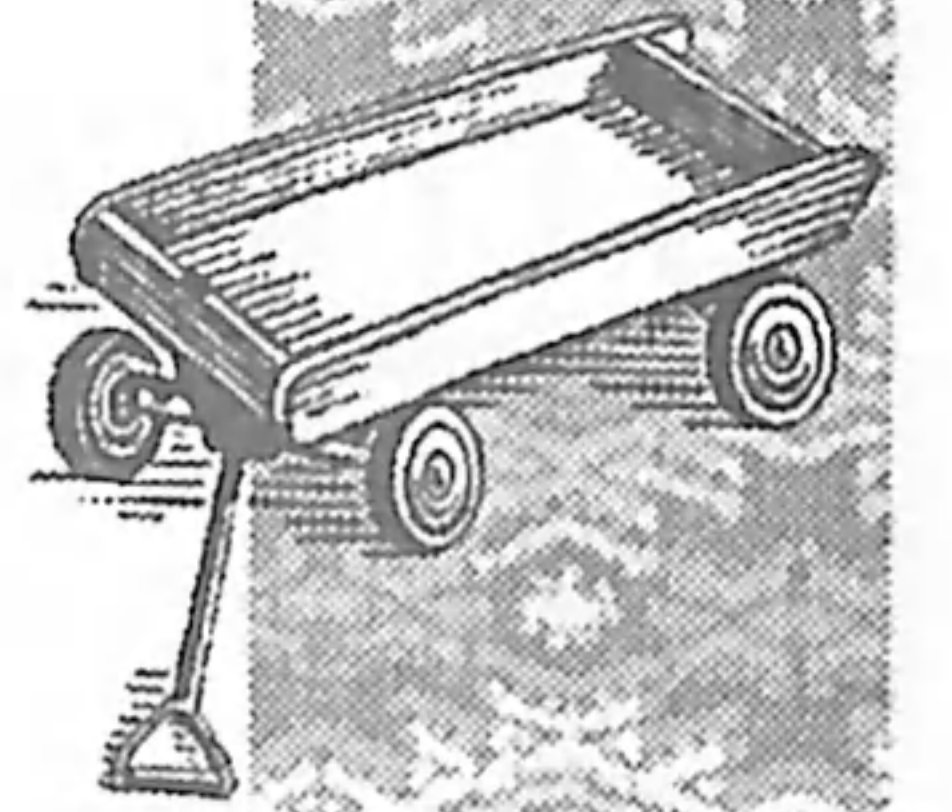
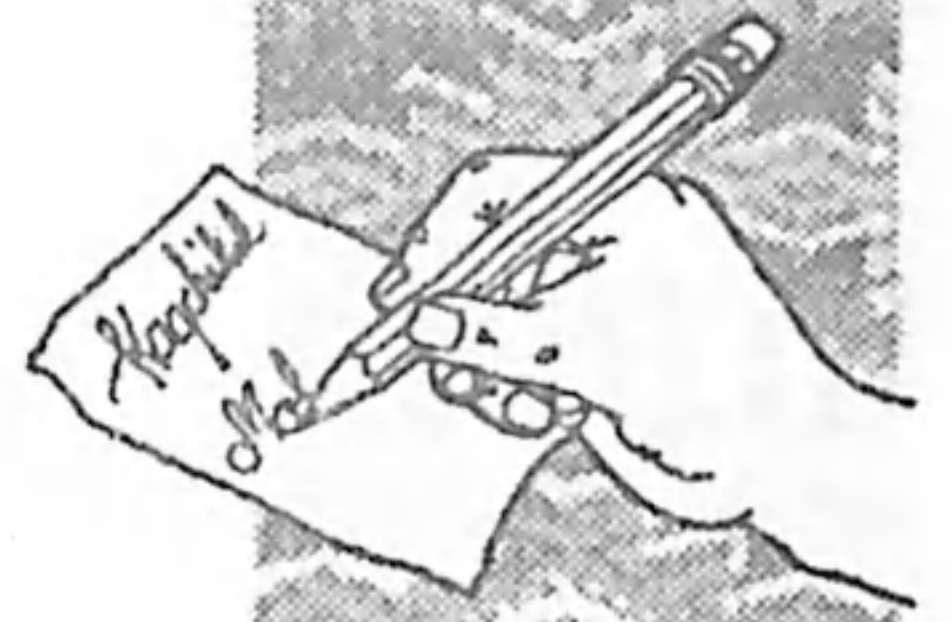



# Tqab'ana' rachib'äl ri qatinamit

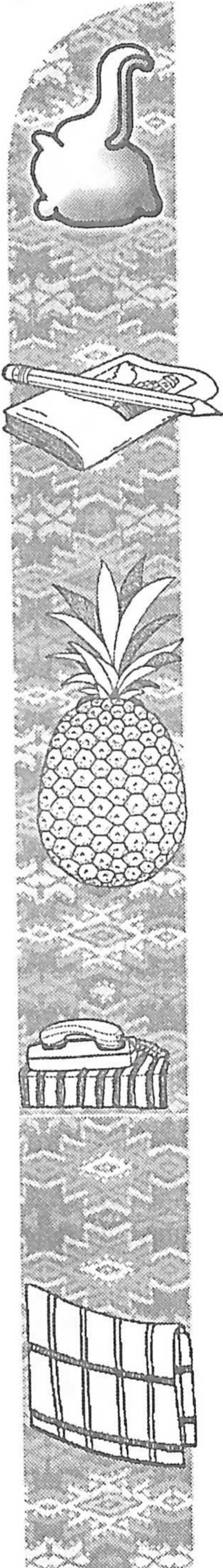
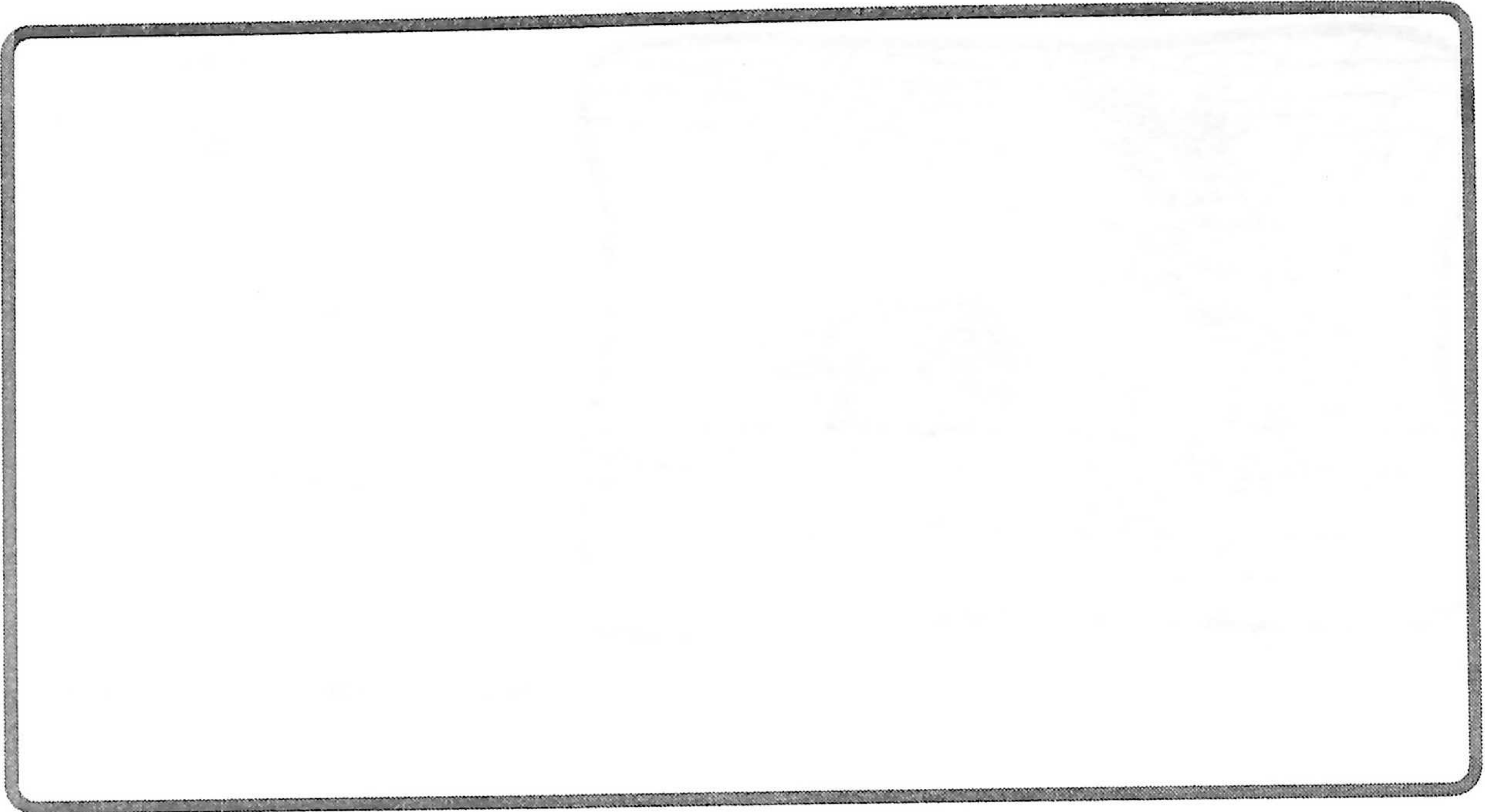

Achike rumeq'enal ri atinamit



Achike jiq'ob'äl nk'ase' pa atinamit.

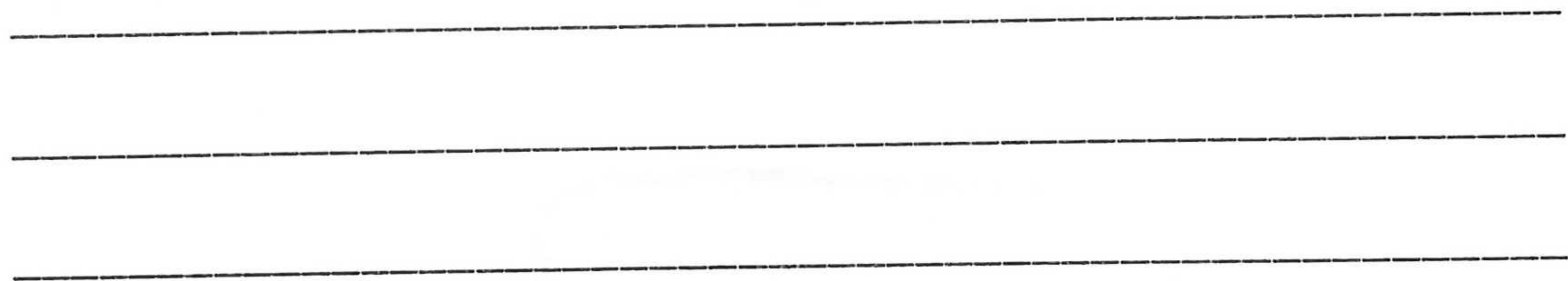

Achike ruwäch ichaj nk'ase' pa atinamit.

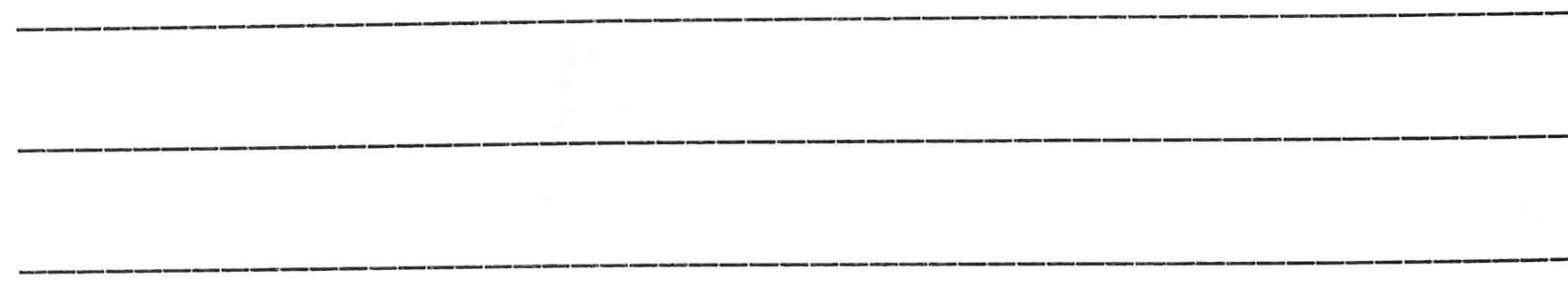

Ri fijoxela' nkib'än kachib'äl ri kitinamit, we tew, we meq'ën, chuqa' tikitz'ib'aj ri jalajöj ruwäch taq che' ri yek'ase' pa kitinamit.

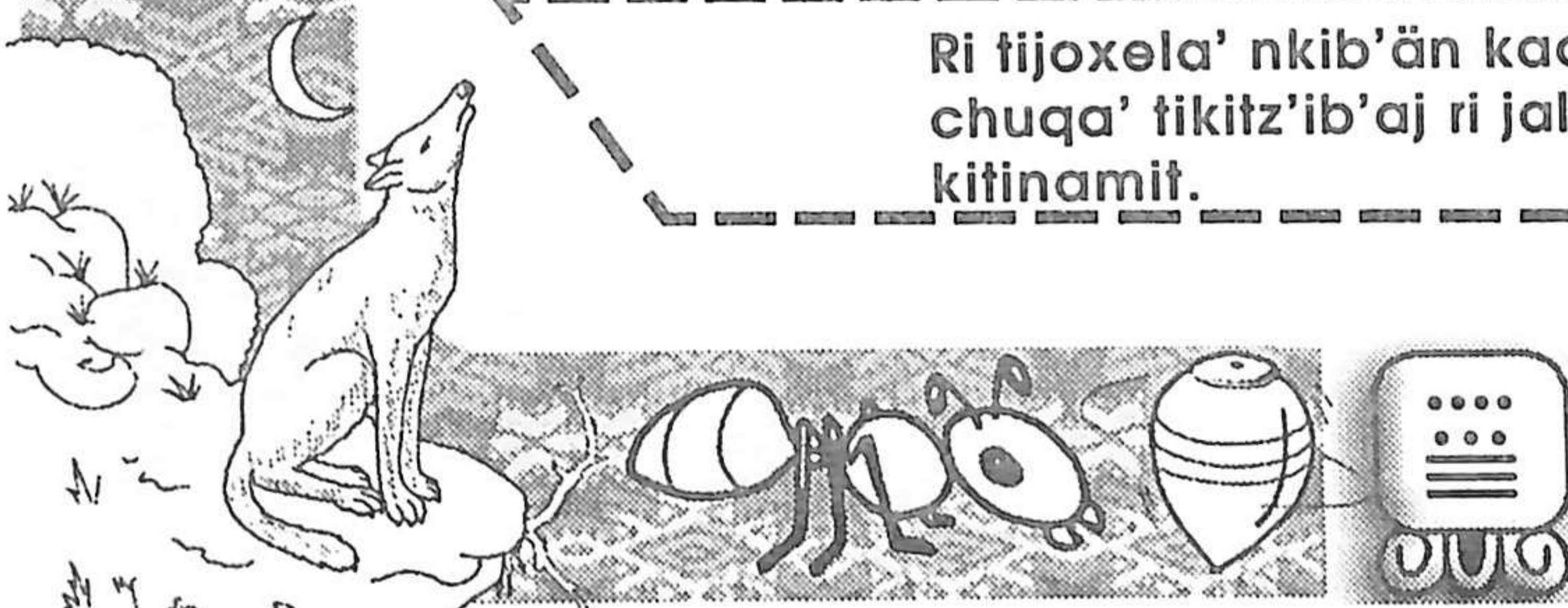

# Tzijonem:

Ri ruwach'ulew jalajöj rumeq'enal.  
 E k'ó tinamit yalan e tew.  
 E k'ó tinamit e meq'en.  
 E k'ó tinamit ri loman kimeq'enal.



## Kojsamäj qonojel.

Tqetamaj akuchi yek'ase' ri ruwäch taq che'

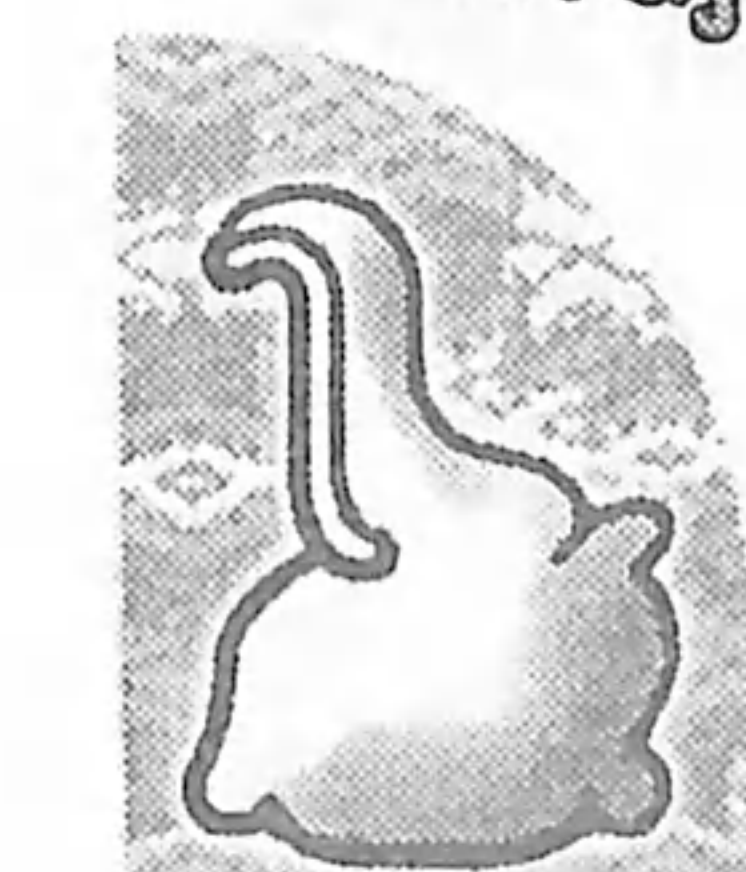
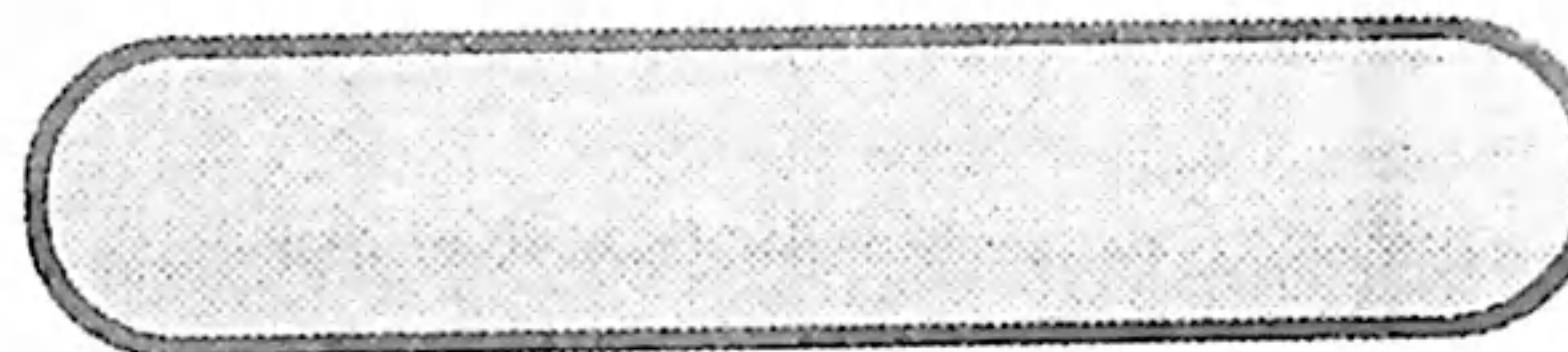
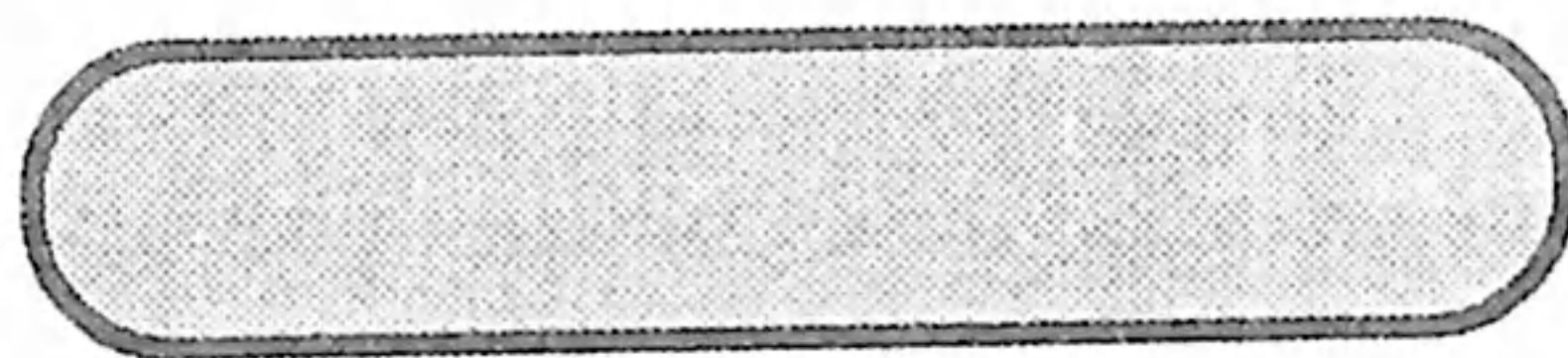
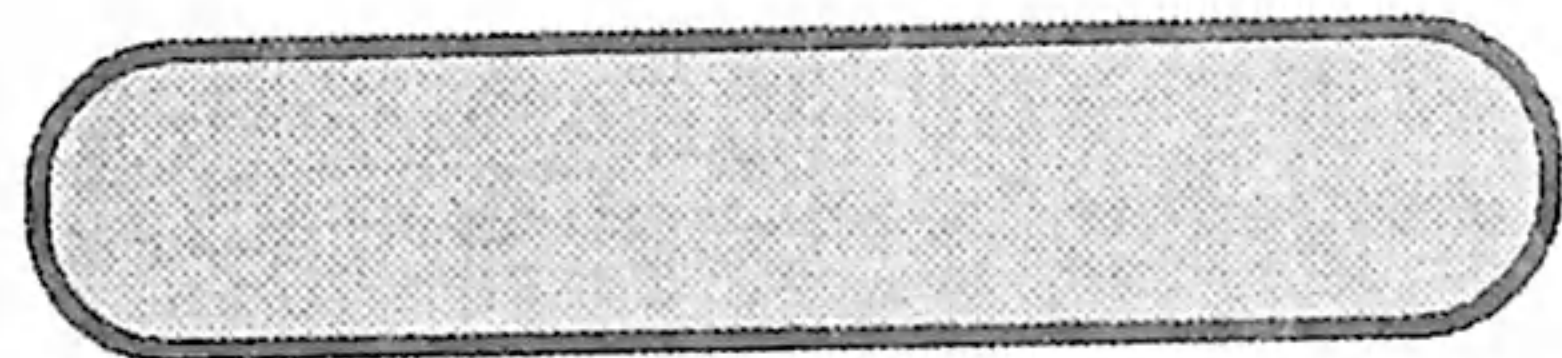
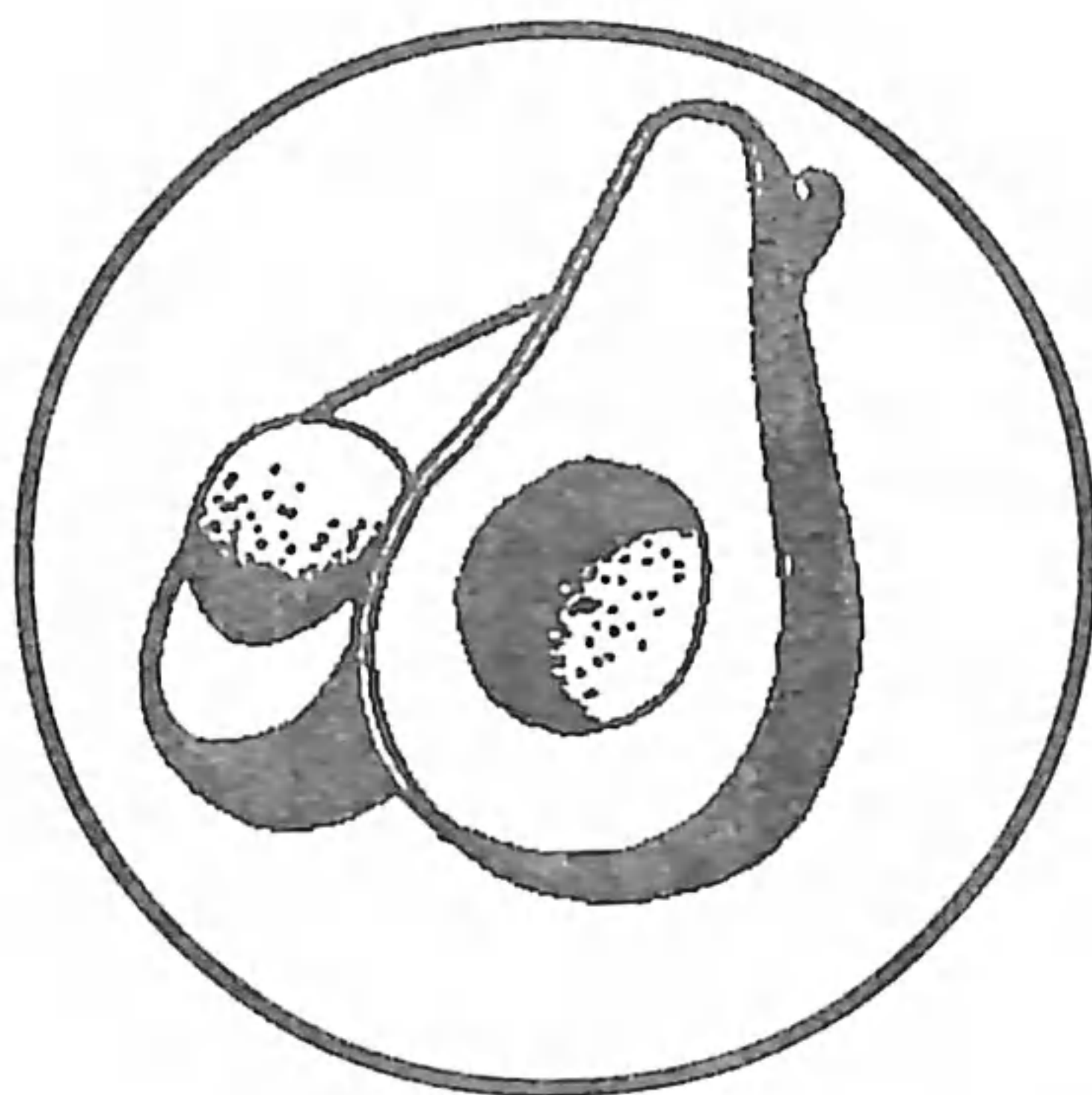
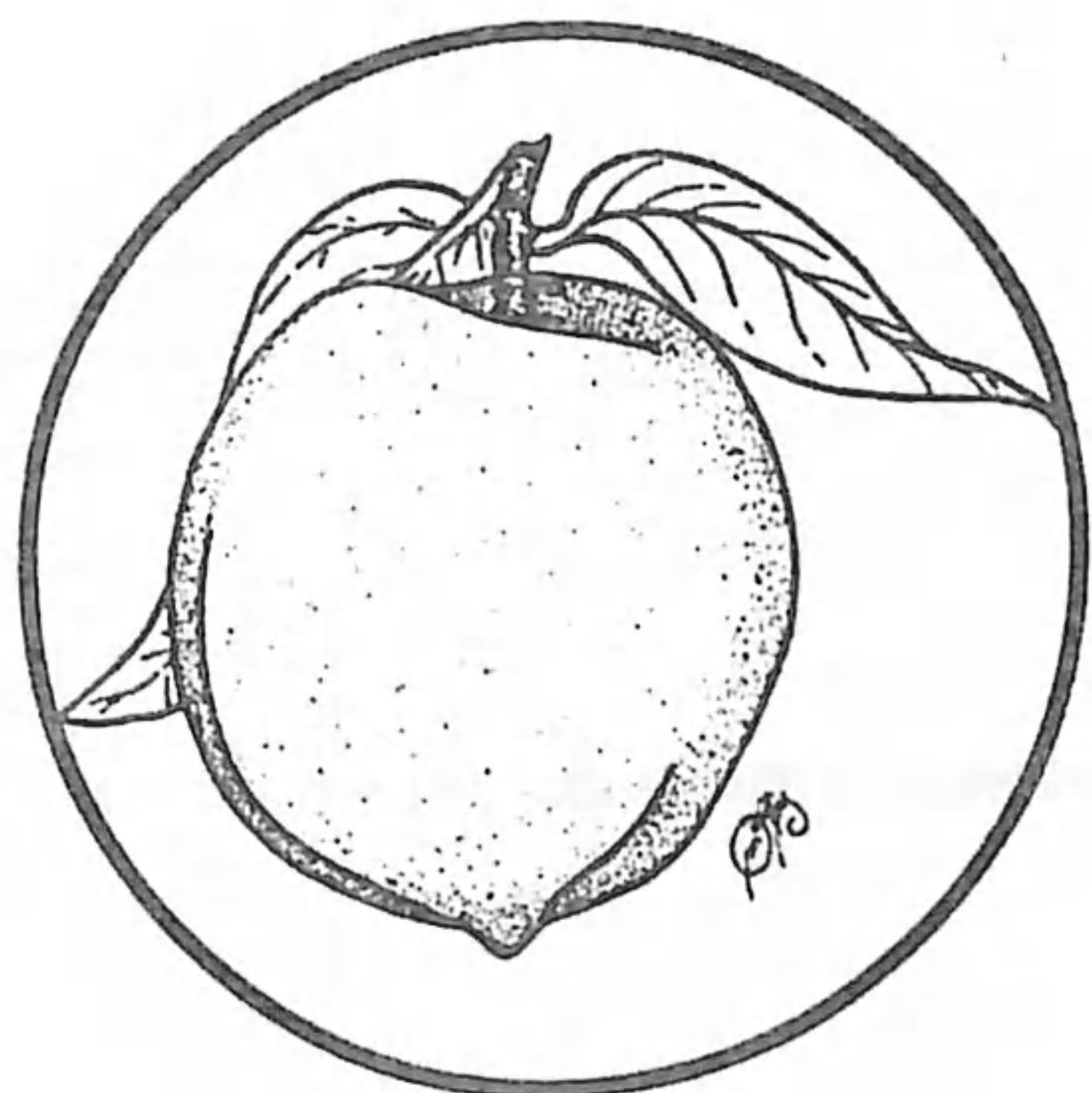

## Kojsamäj pa qayonil

Tiqatz'eta ri qetaman.

Ri q'enum nk'ase' pa \_\_\_\_\_

Ri kaqaq'oq nk'ase' pa \_\_\_\_\_

Ri ch'öp nk'ase' pa \_\_\_\_\_

Ri tulül nk'ase' pa \_\_\_\_\_

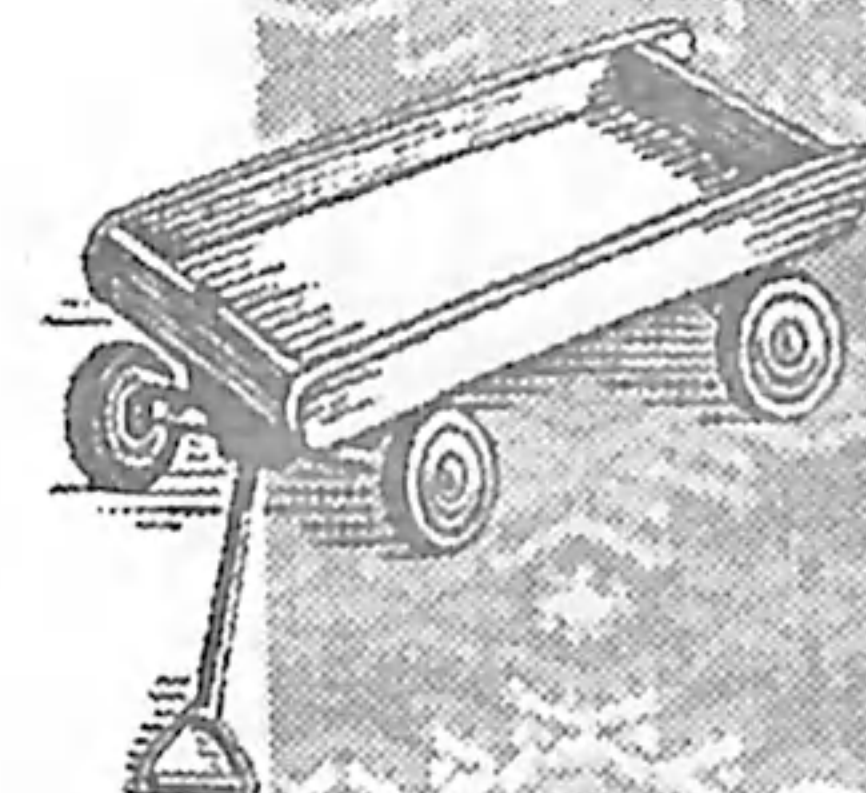
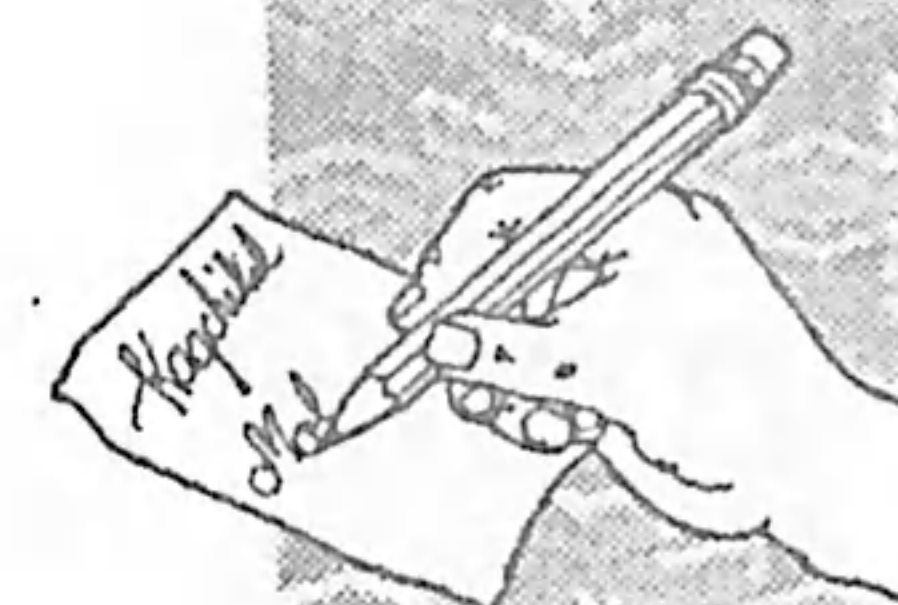

Ri tijoxela' nkib'ij ri jiq'ob'al yek'ase' pa taq jalajöj ruwäch ulew.

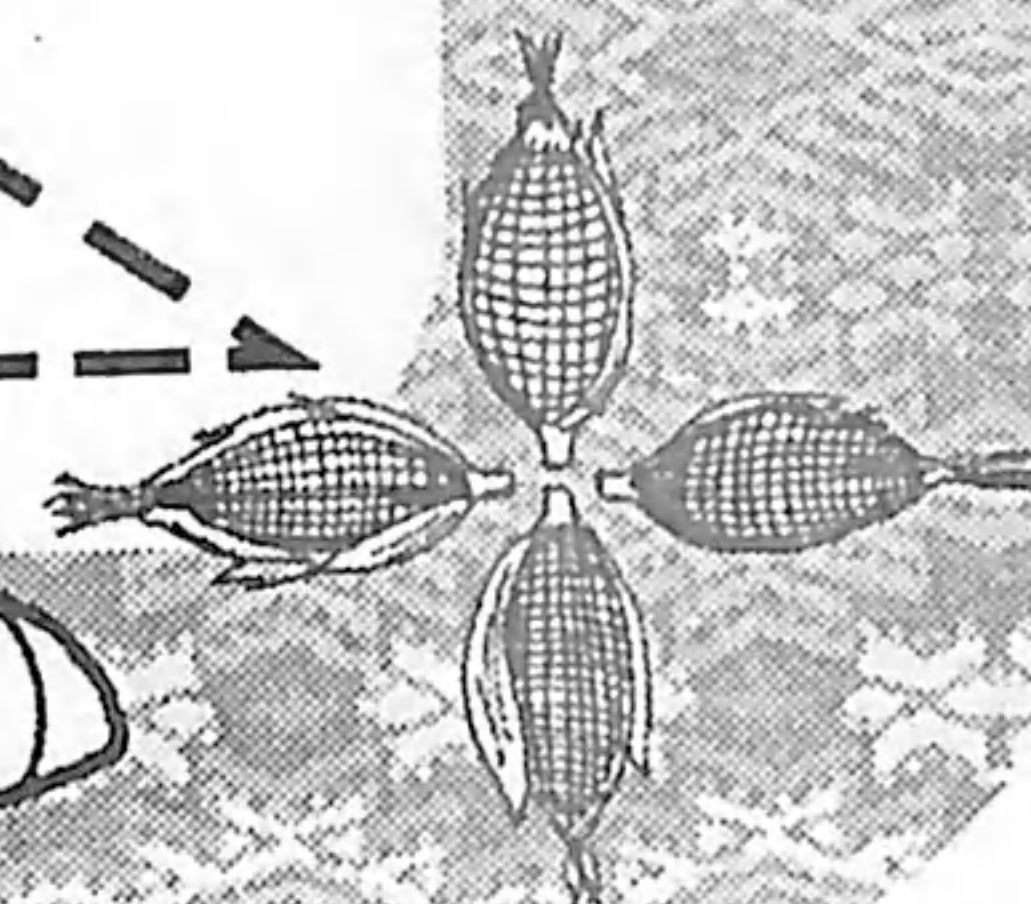

# Ri tiko'n yek'ase' pa tew ulew



Ri Xinwetamal

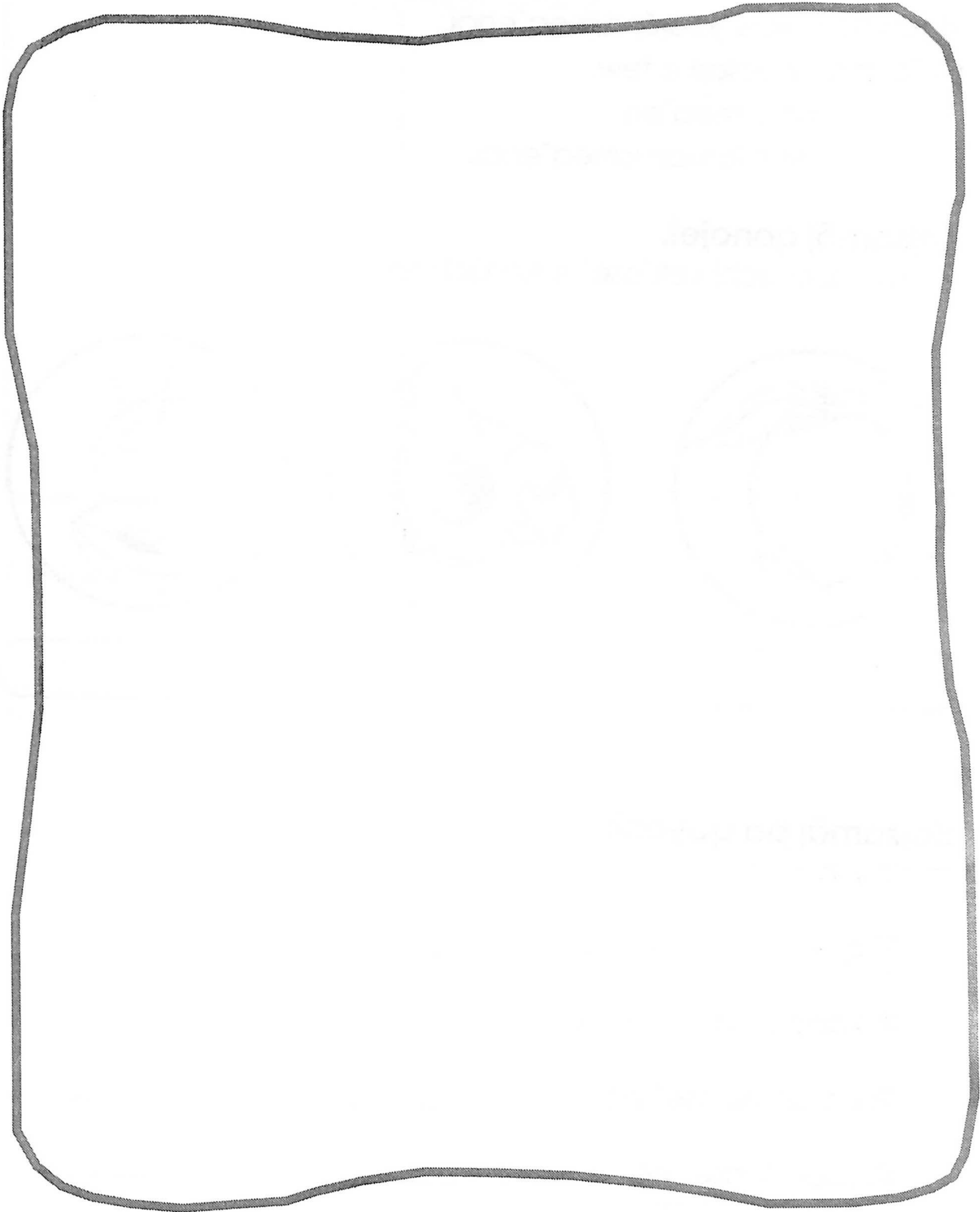
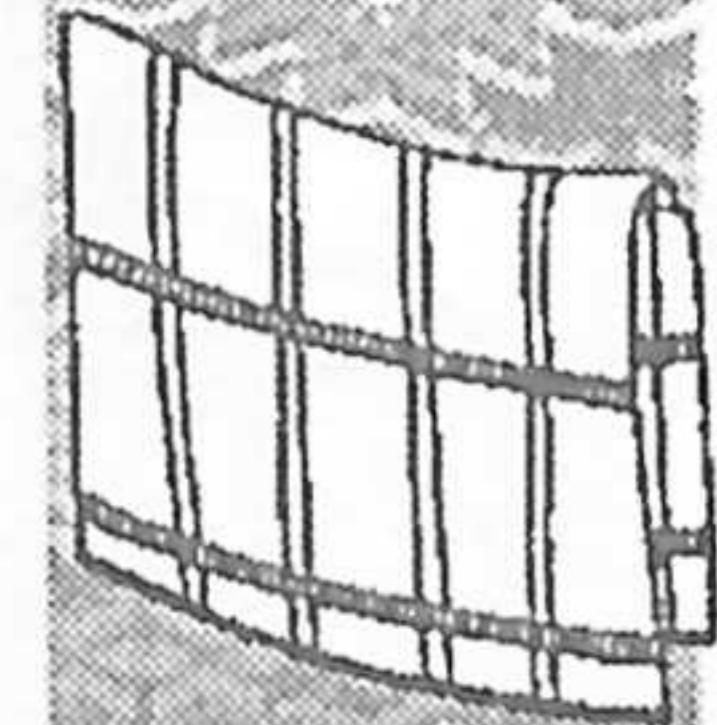

Ri tijoxela' nkib'an rachib'al chuqa' nkiya' kib'i' ri jalajöj ruwäch tiko'n yek'ase' pa tew ulew.



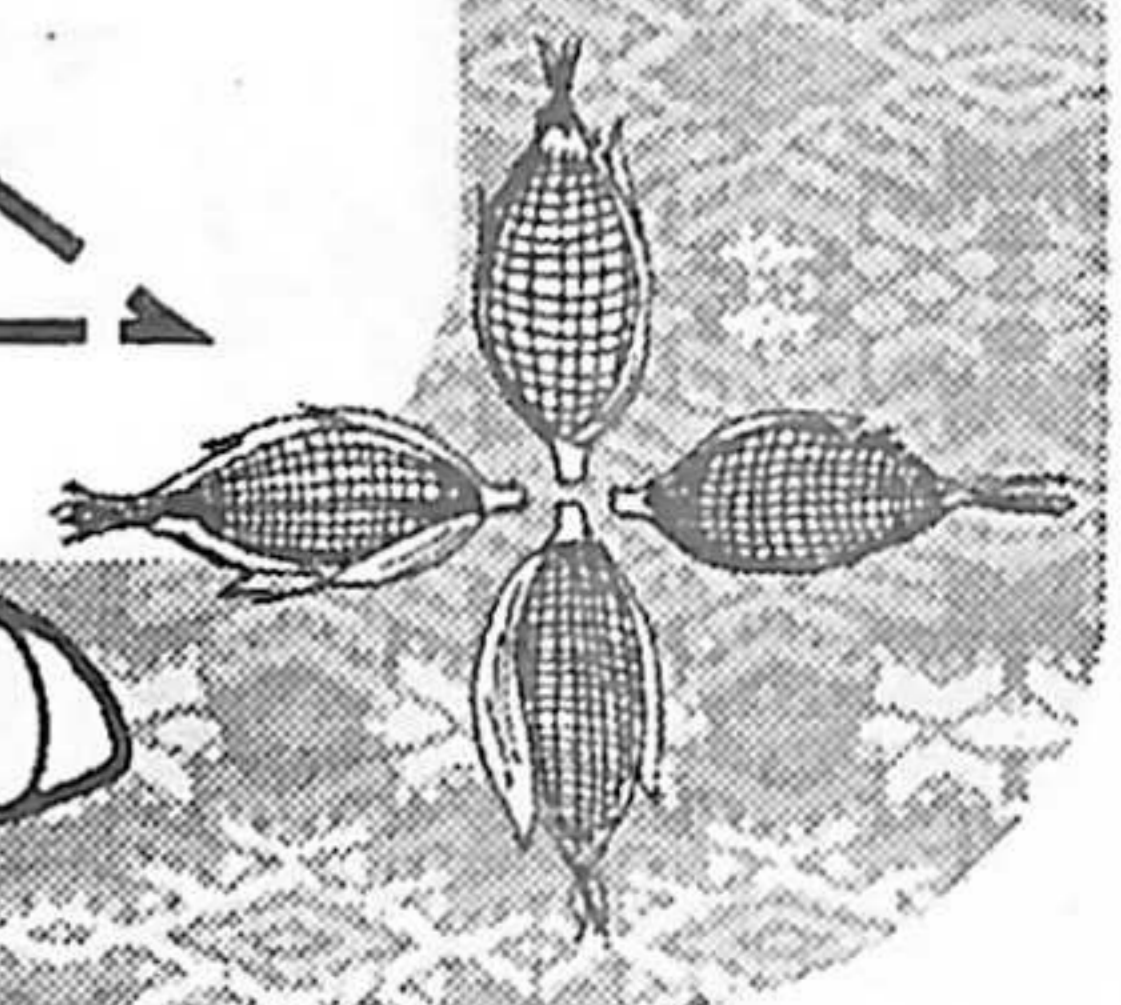
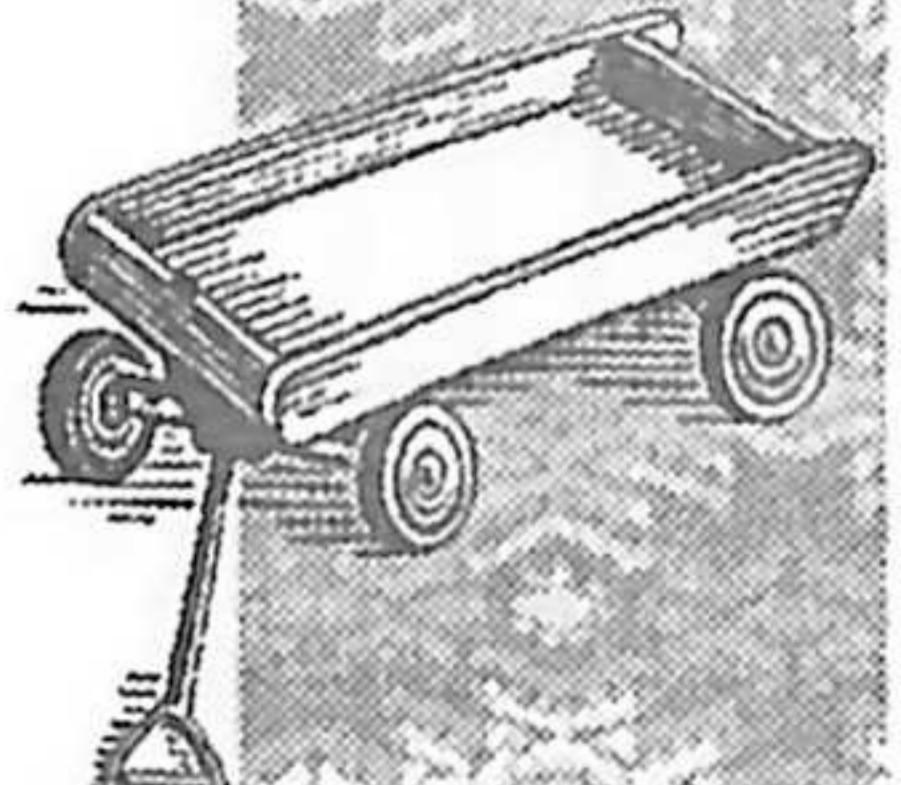
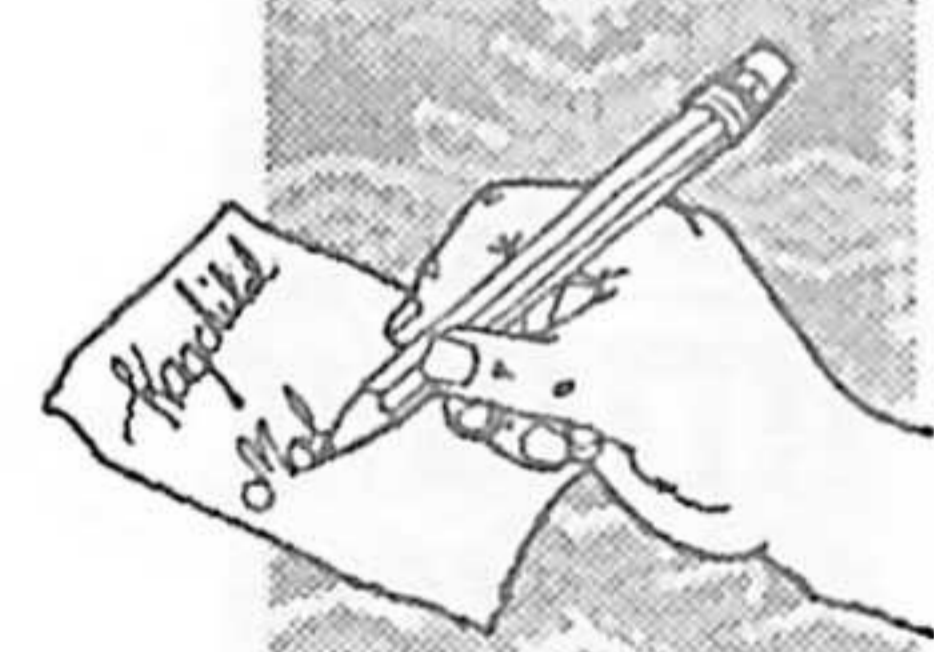

Ri tiko'n  
yek'ase' pa  
liloj ulew

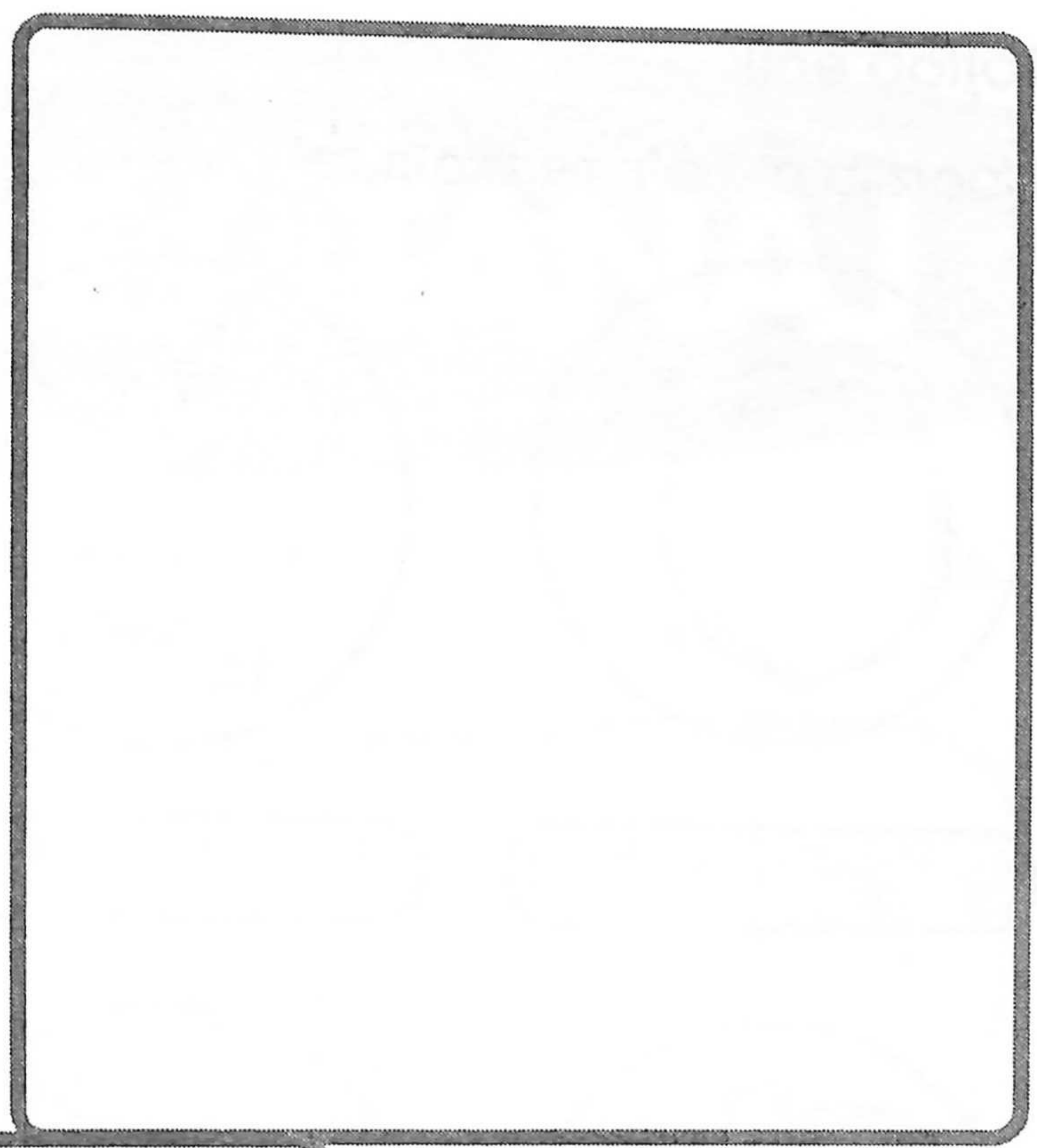

Ri tiko'n  
yek'ase' pa  
meq'ën ulew

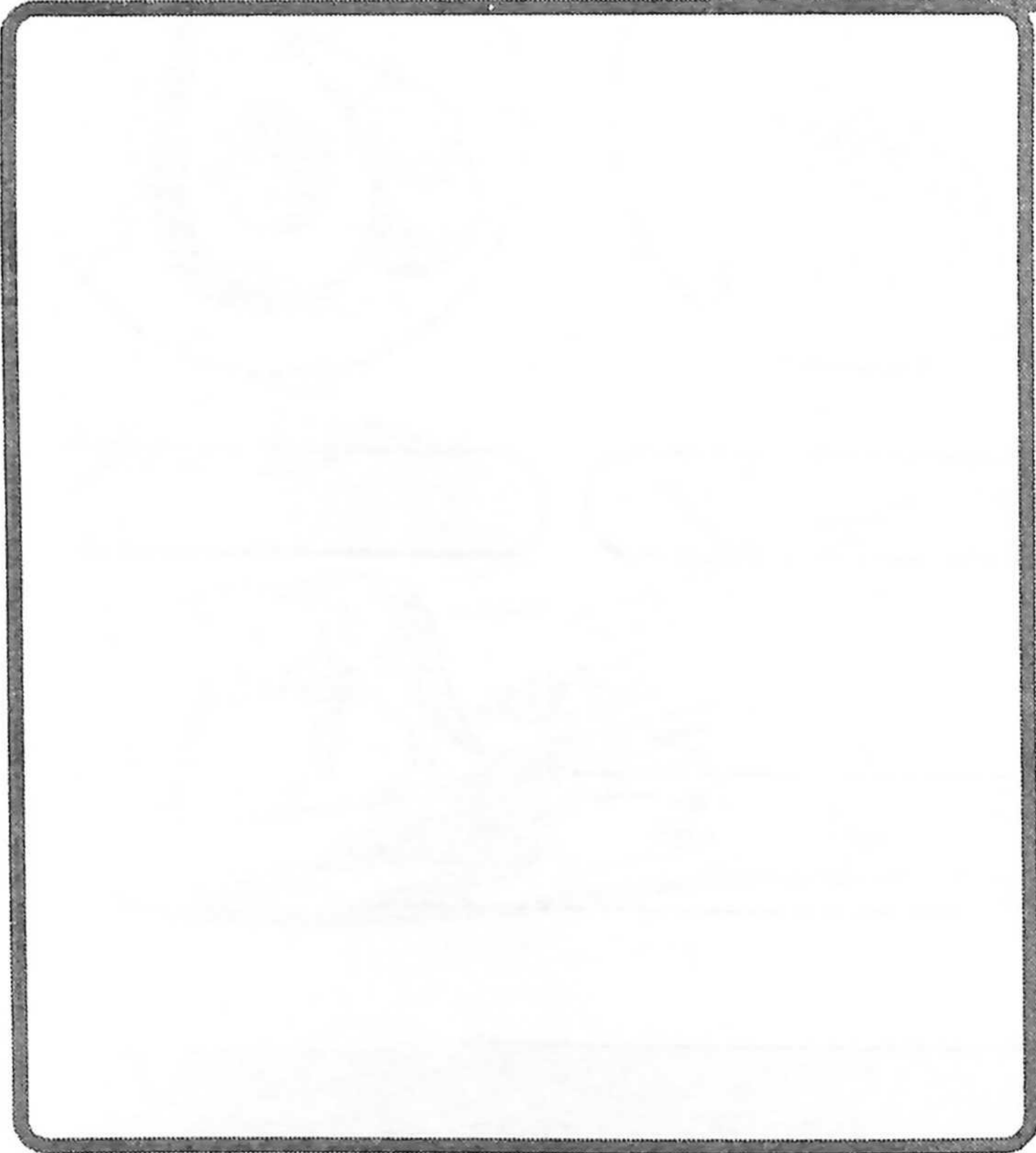

Ri tijoxela' nkib'än rachib'äl chuqa' nkiya' kib'i' ri  
jalajöj ruwäch tiko'n yek'ase' pa liloj ulew.

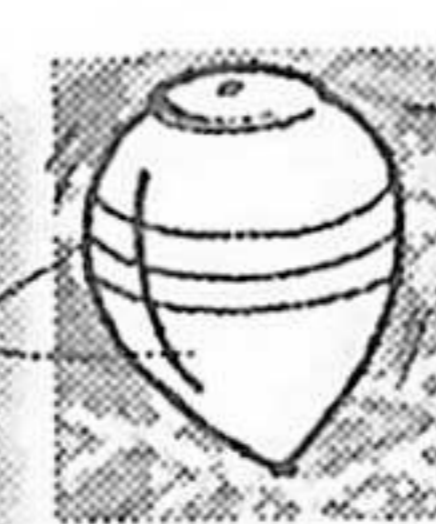

# Tojtob'enik

Nqatz'ib'aj kib'i' re tiko'n re'

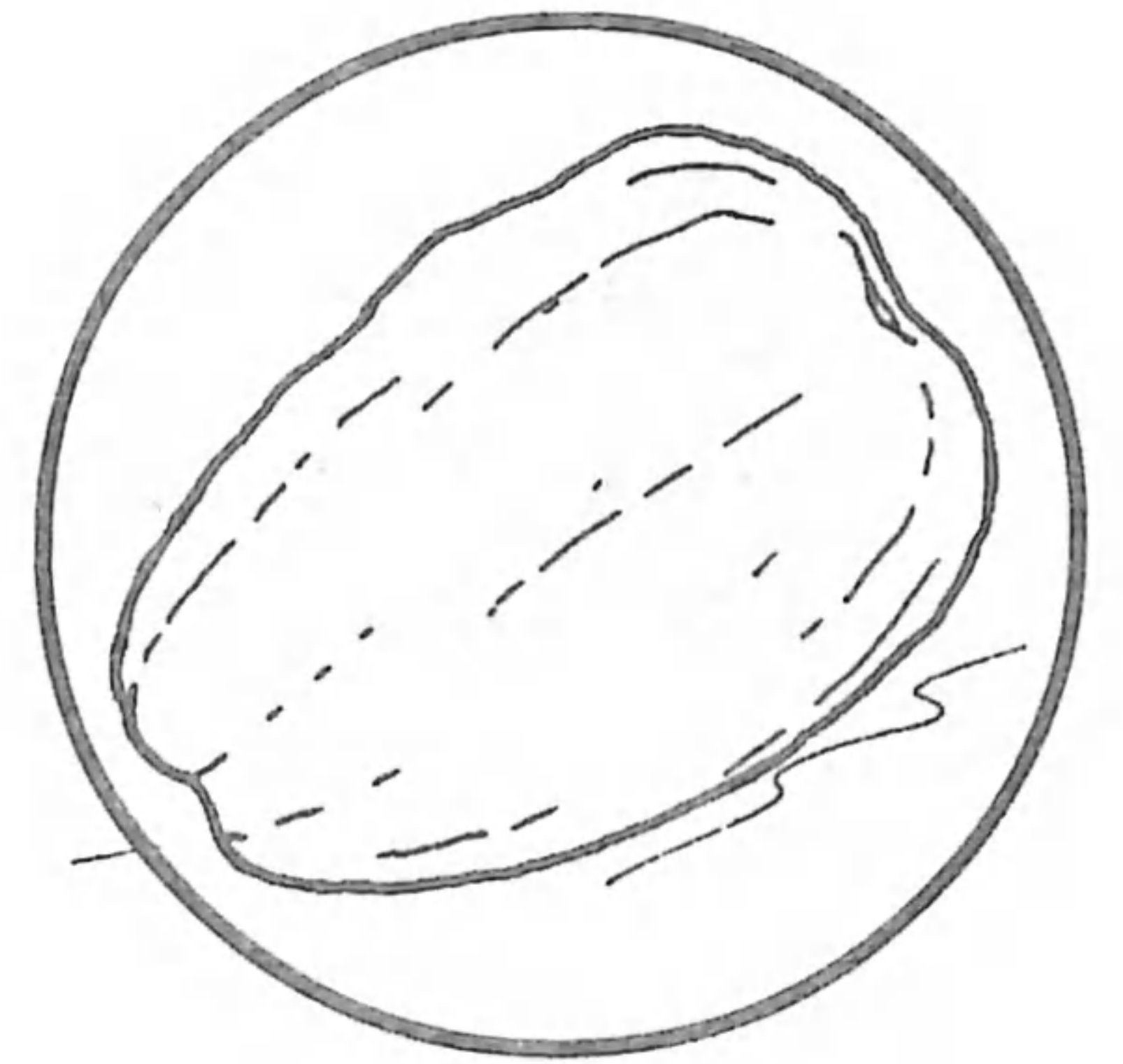
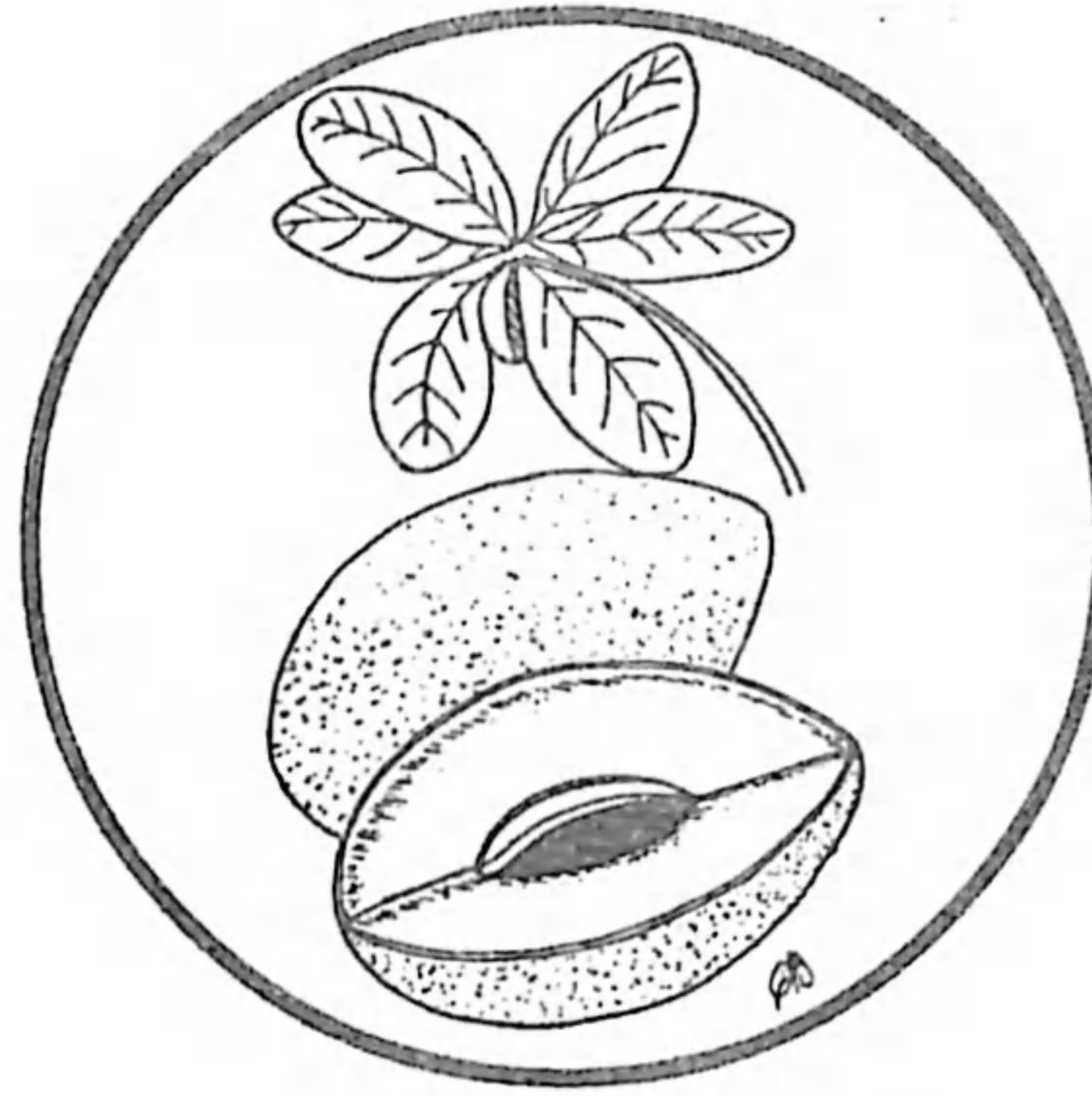
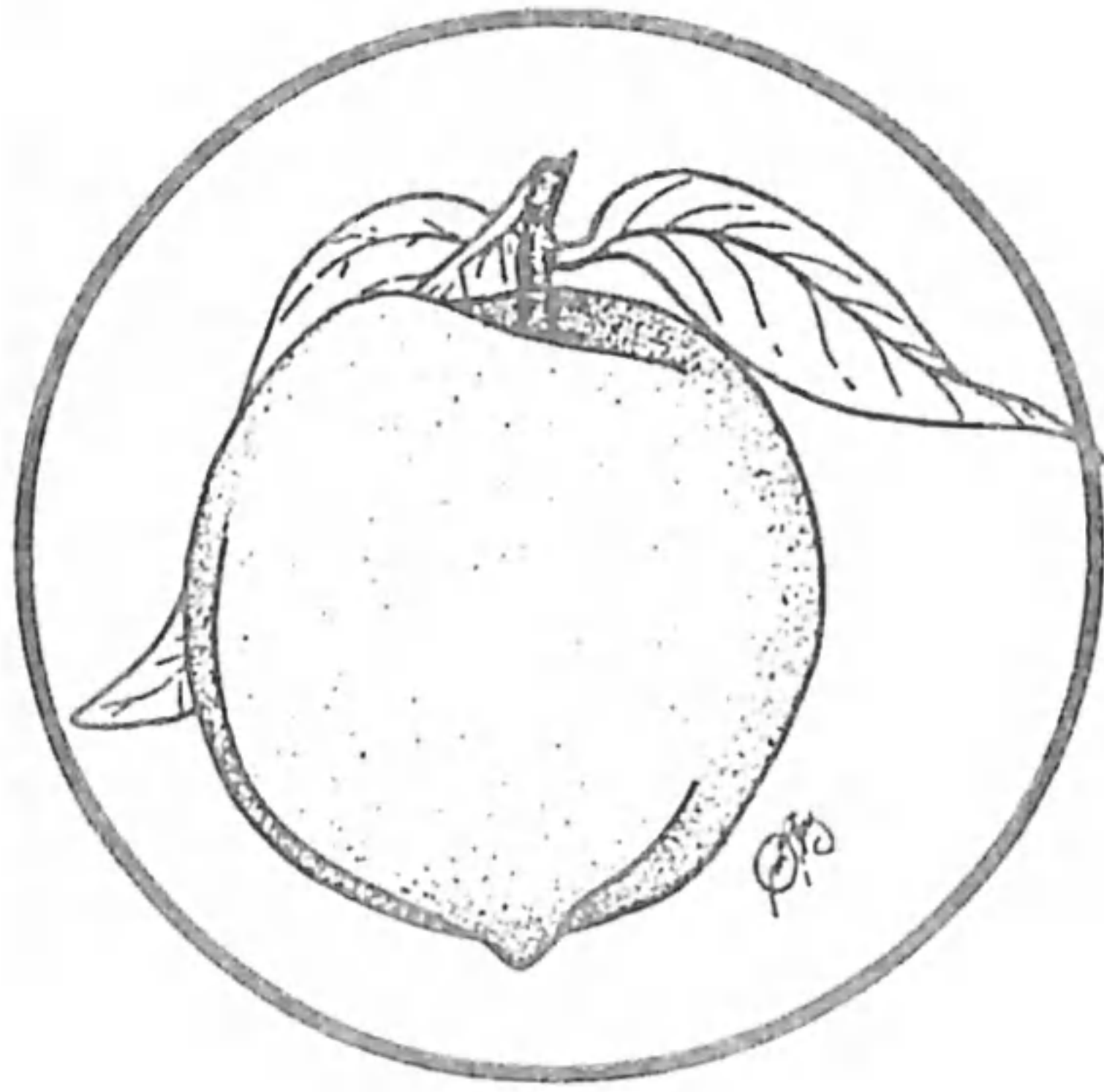
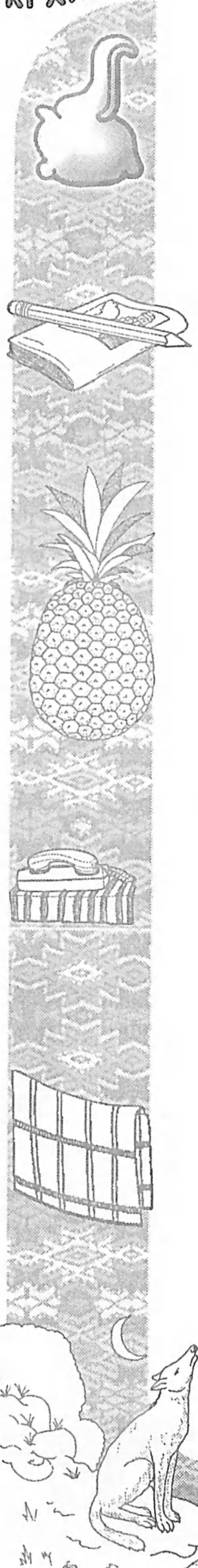



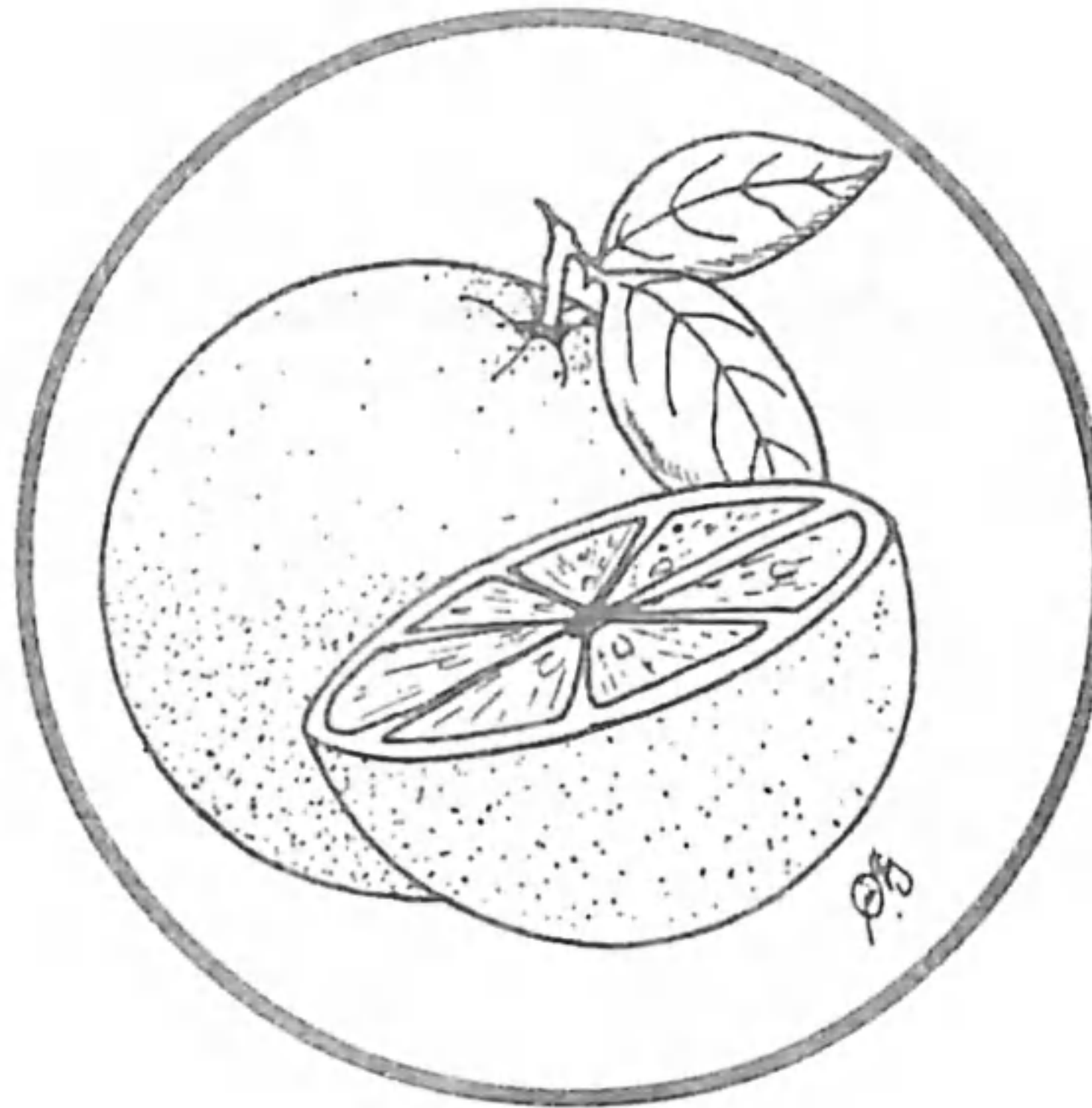
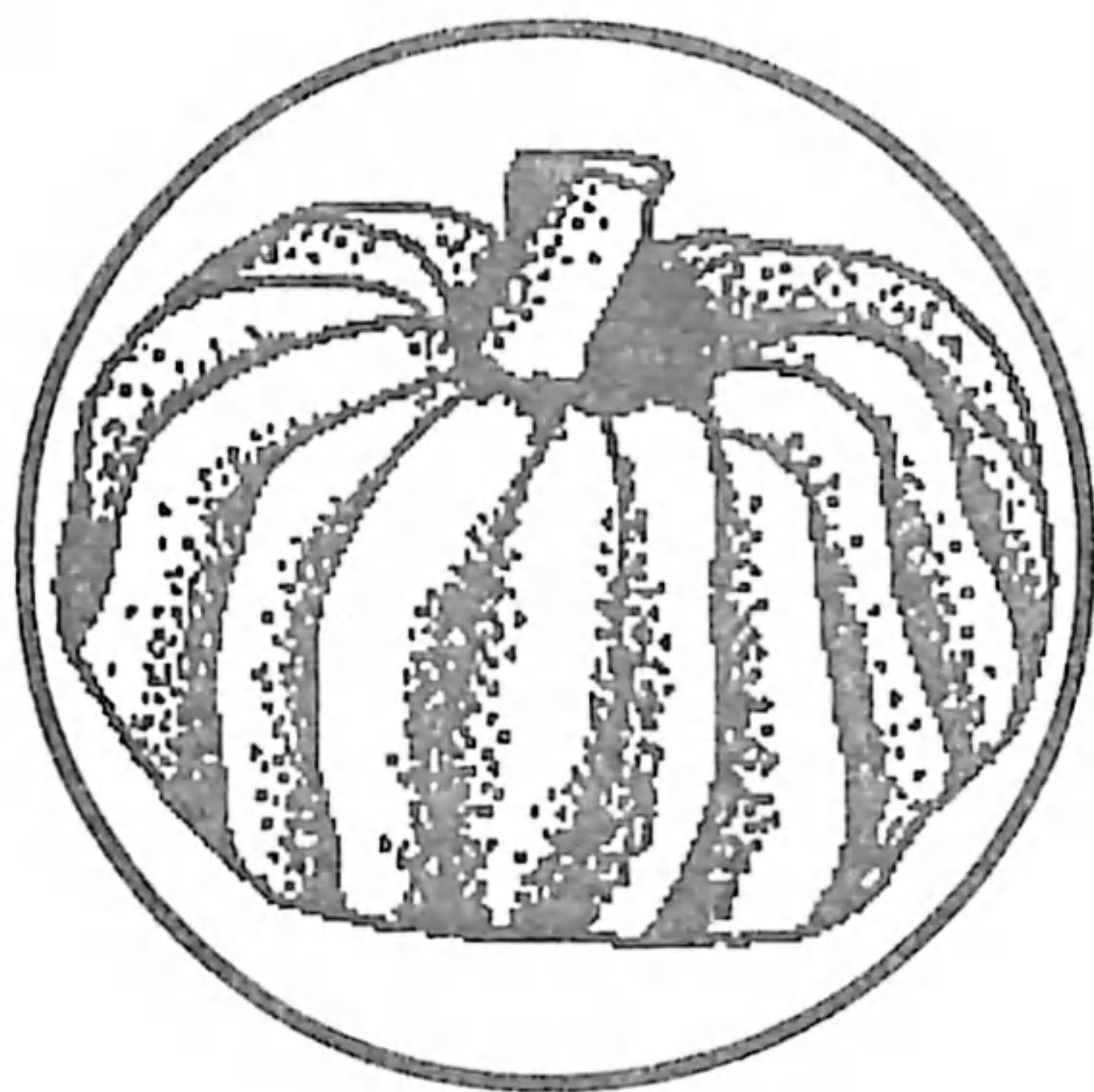



Ri ik nk'ase' pa \_\_\_\_\_

Ri kaqaq'oq nk'ase' pa \_\_\_\_\_

Ri tura's nk'ase' pa \_\_\_\_\_

Ri alanx nk'ase' pa \_\_\_\_\_

Ri tijoxela' nkib'an rachib'al chuqa' nkiya' kib'i' ri  
jalajöj ruwäch tiko'n yek'ase' pa meq'en  
ulew.



# RUB'ELEJ TANAJ

## Ri chikopi'

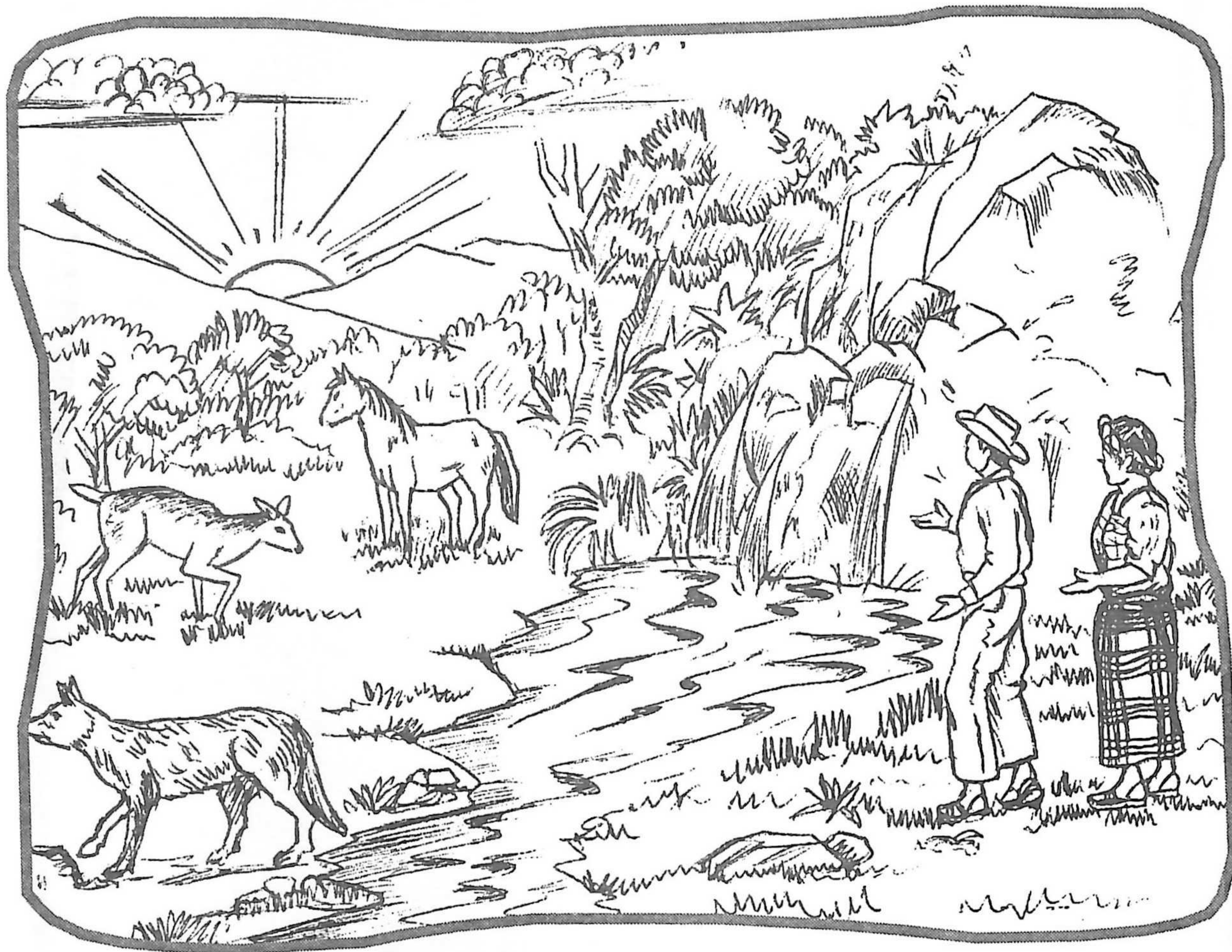

### Ri etamanik nuq'i' ri tijoxel:

Kib'i' ri jalajöj chikopi'.  
Yerajilaj ri chikopi' e k'o pa koral.  
Ntzijon pa ruwi' ri chikopi' aj pa juyu', aj chuwajay.

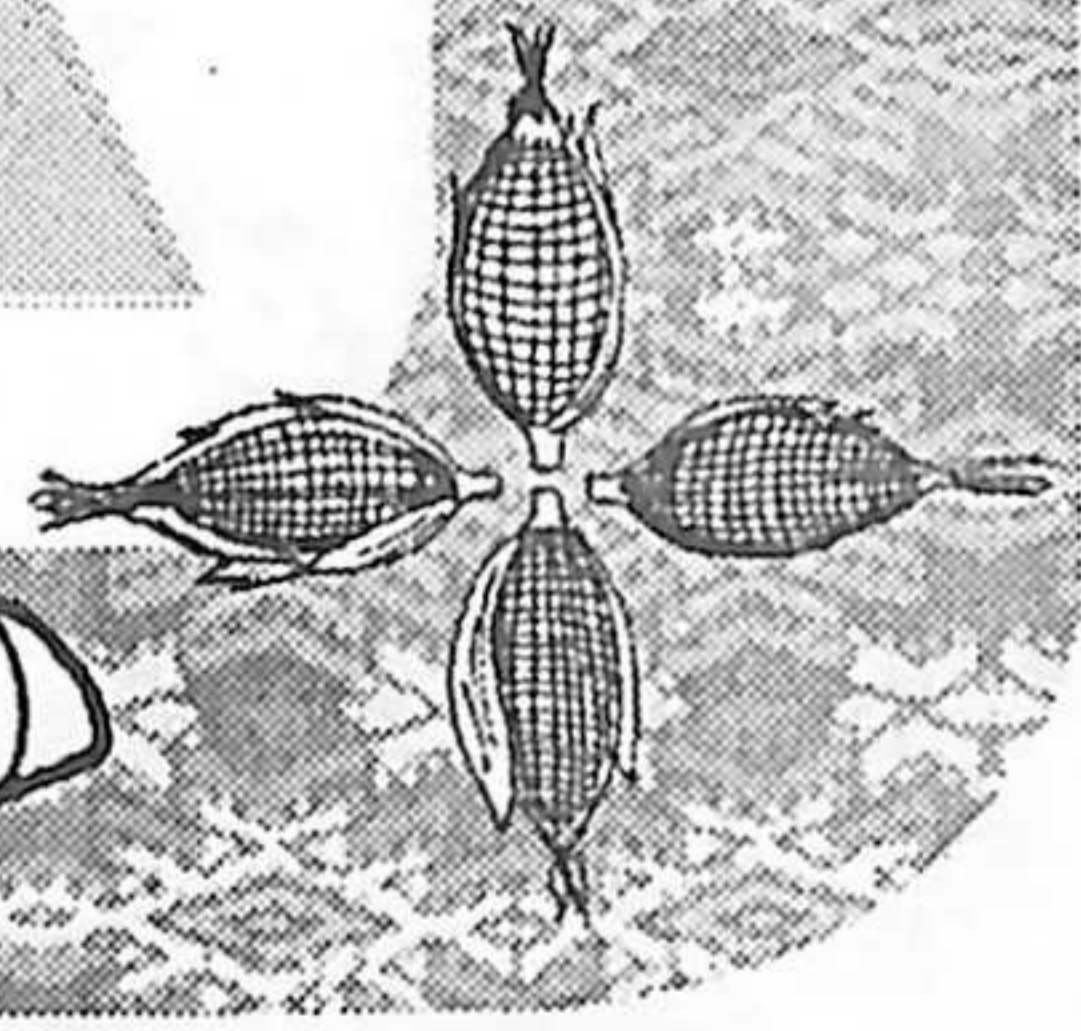
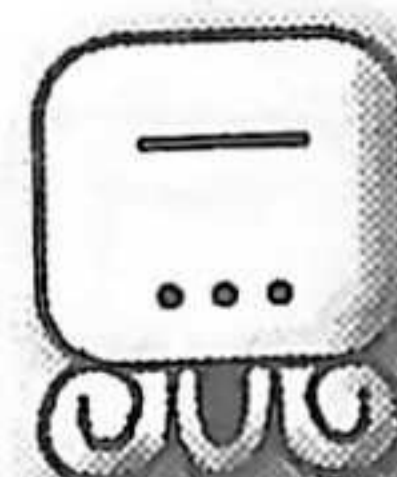



# Kachib'äl chikopi' e aj chuwajay



Ri Wetaman

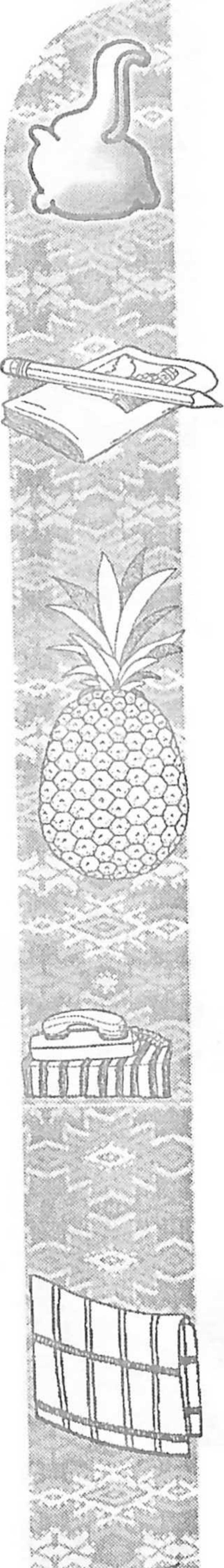
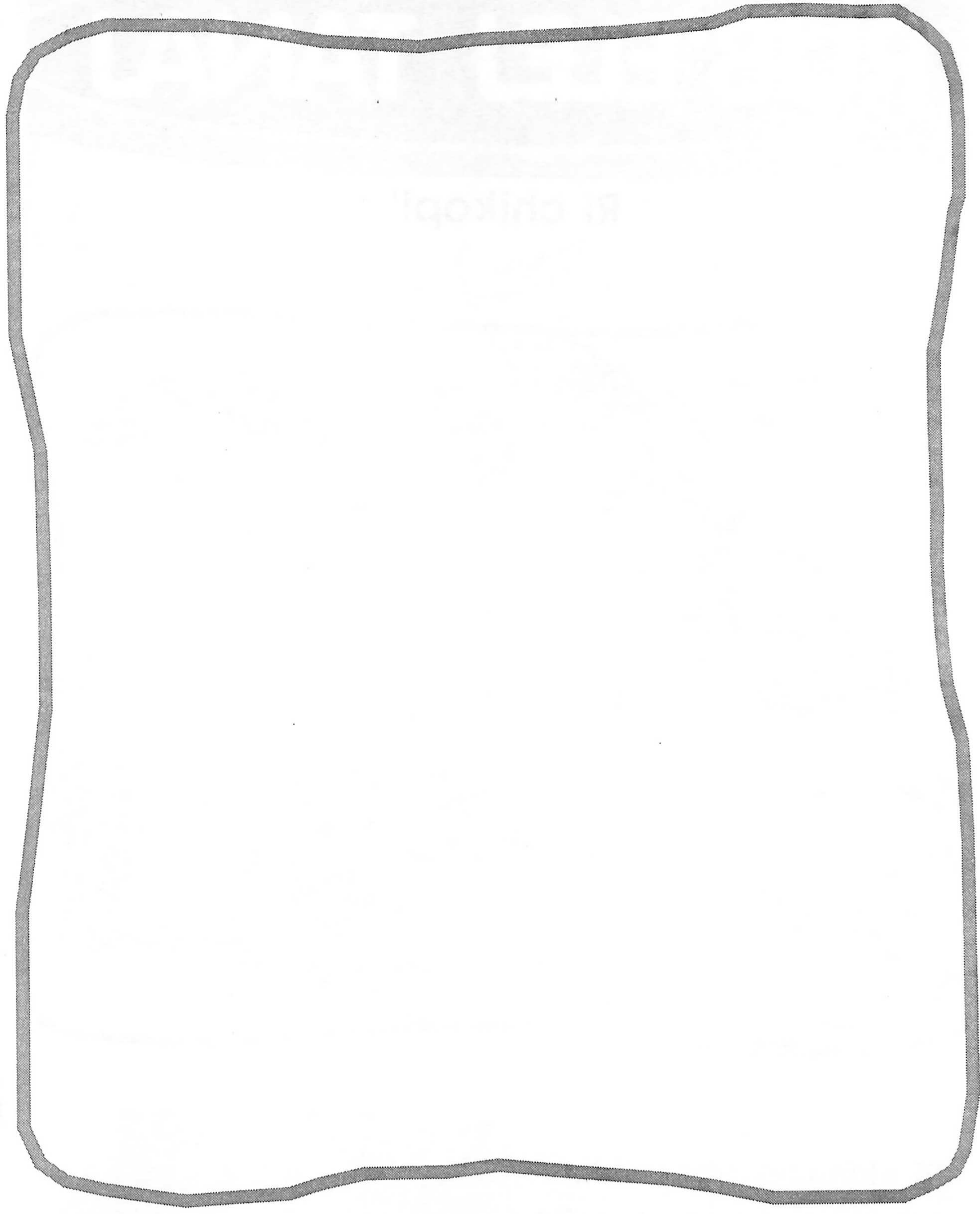

Ri tijoxela' nkitz'am kachib'äl ri chikopi', chuqa' xe kixikin nkitz'ib'aj kib'i'.



# Kachib'äl chikopi' e aj pa juyu'

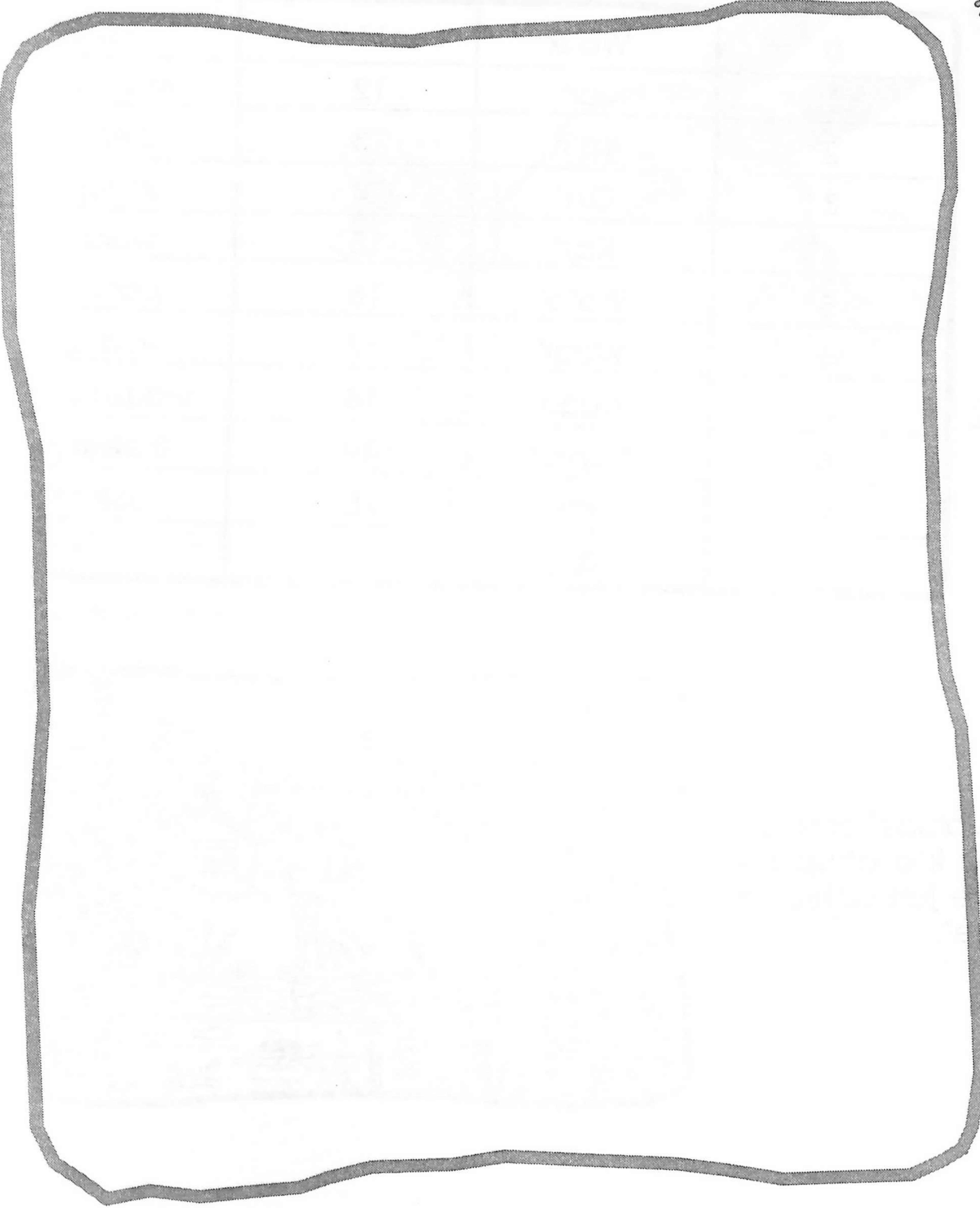

Ri tijoxela' nkitz'am kachib'äl ri chikopi', chuqa' xe kixikin nkitz'ib'aj kib'i'.



# Ri maya' ajilanik

0	Wa'ix	11	julajuj
1	Jun	12	Kab'lajuj
2	Ka'i'	13	oxlajuj
3	Oxi'	14	kajlajuj
4	Kaji'	15	wolajuj
5	Wo'o'	16	waqlajuj
6	Waqi'	17	wuqlajuj
7	Wuqu'	18	waqxaqlajuj
8	Waqxaqi'	19	B'elejlajuj
9	B'eleje'	20	Juk'al
10	lajuj		



Jarupe' chikopi' e k'o chupam re jun achib'al re'.

Ri tijoxela' nkikamuluj ri maya' ajilanik.  
 Nkib'ij kib'i' ri chikopi' e k'o chupam ri achib'al.  
 Nkajilaj ri chikopi' e k'o chupam ri achib'al

# Ri tz'unün

Niropöp niropöp  
la ti tz'unün  
Kan nujulej  
rupam la ti kotz'i'j.



Niropöp niropöp  
la ti tz'unün  
Kan nujulej  
rupam la ti kotz'i'j.

Nib'e' ke la'  
nipe ke re'  
tiqachapa' ri ti tz'unün

*Xtz'ib'an: Bernardo Quinac.*

¿Achike nub'an ri ti tz'unün?

¿Choj pa ruwi' niropöp ri ti tz'unün?

¿Janipe taq tz'unün yeropöp?

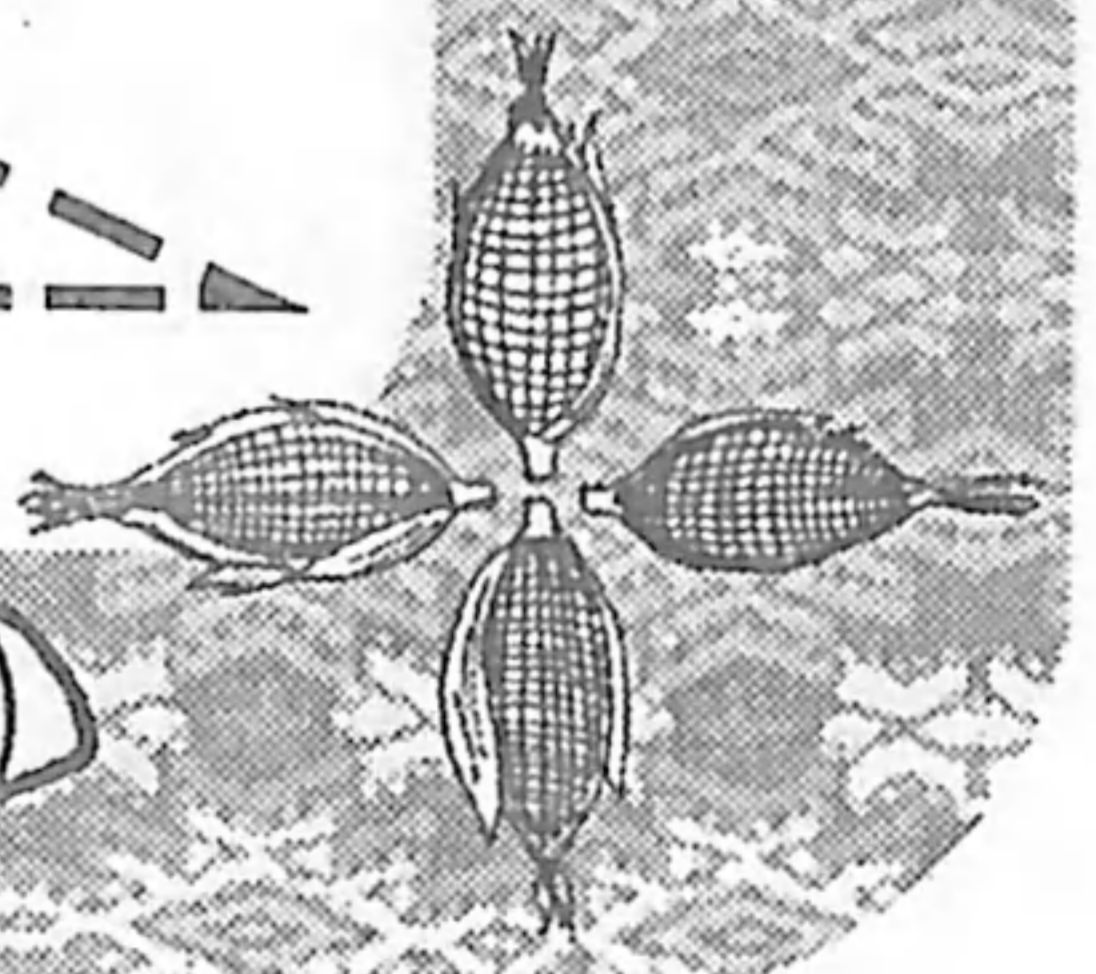
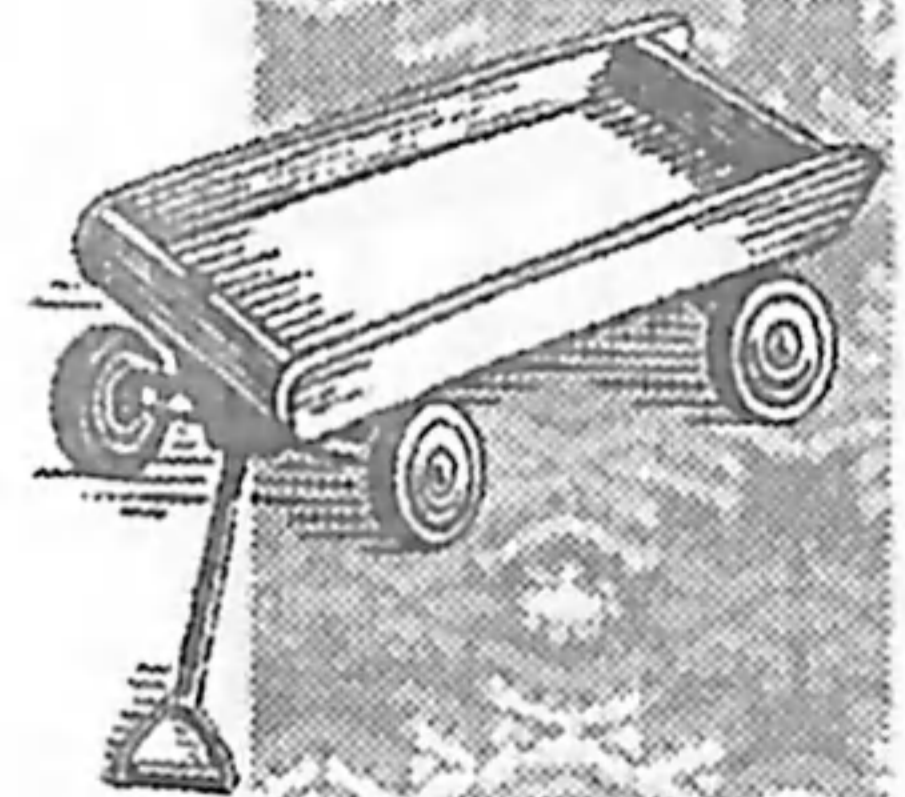

Re jun b'ix re' k'o pa jun yakb'äl b'ix pa Kaqchikel Moloj.

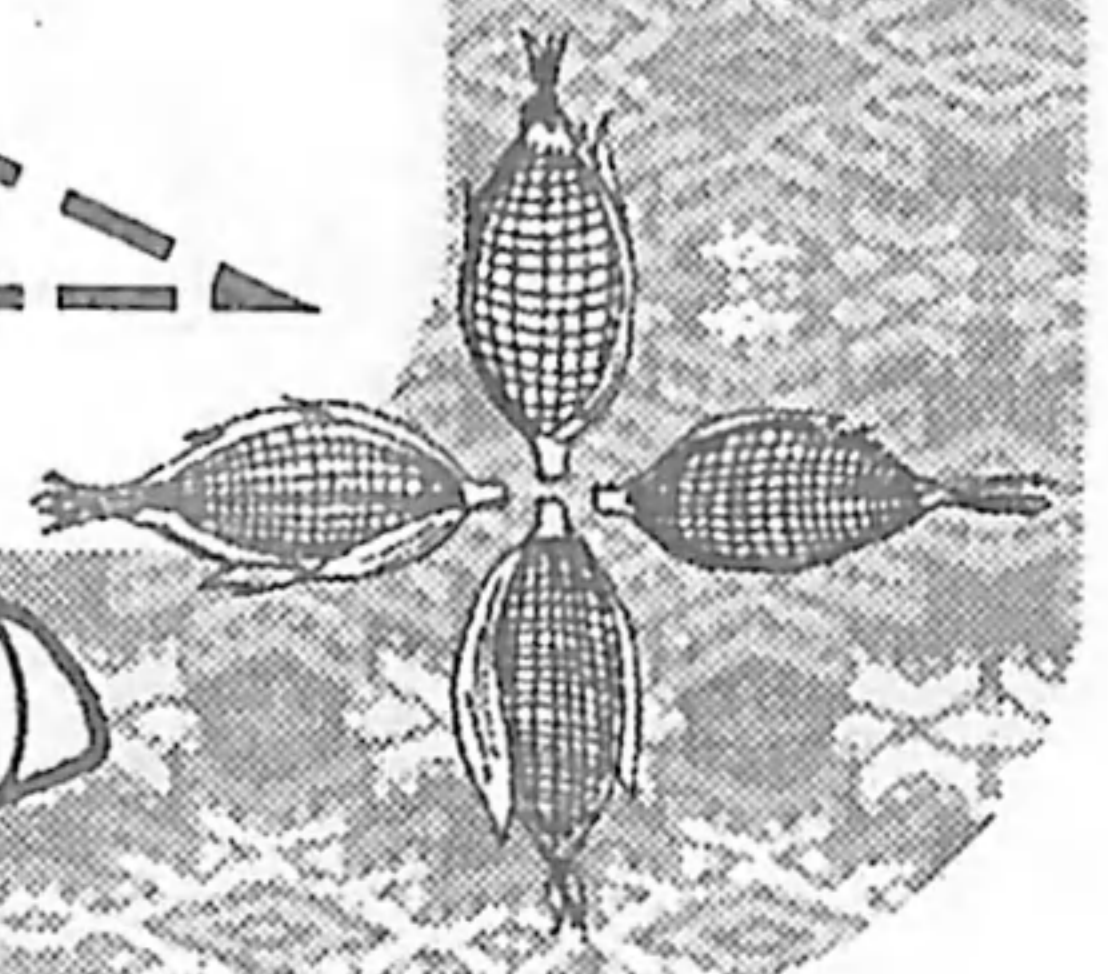

# Kojsamäj pa qayonil

Tqab'onij ri chikopi' yek'ase chuwa jay:



mes



b'alam



ut



wakx

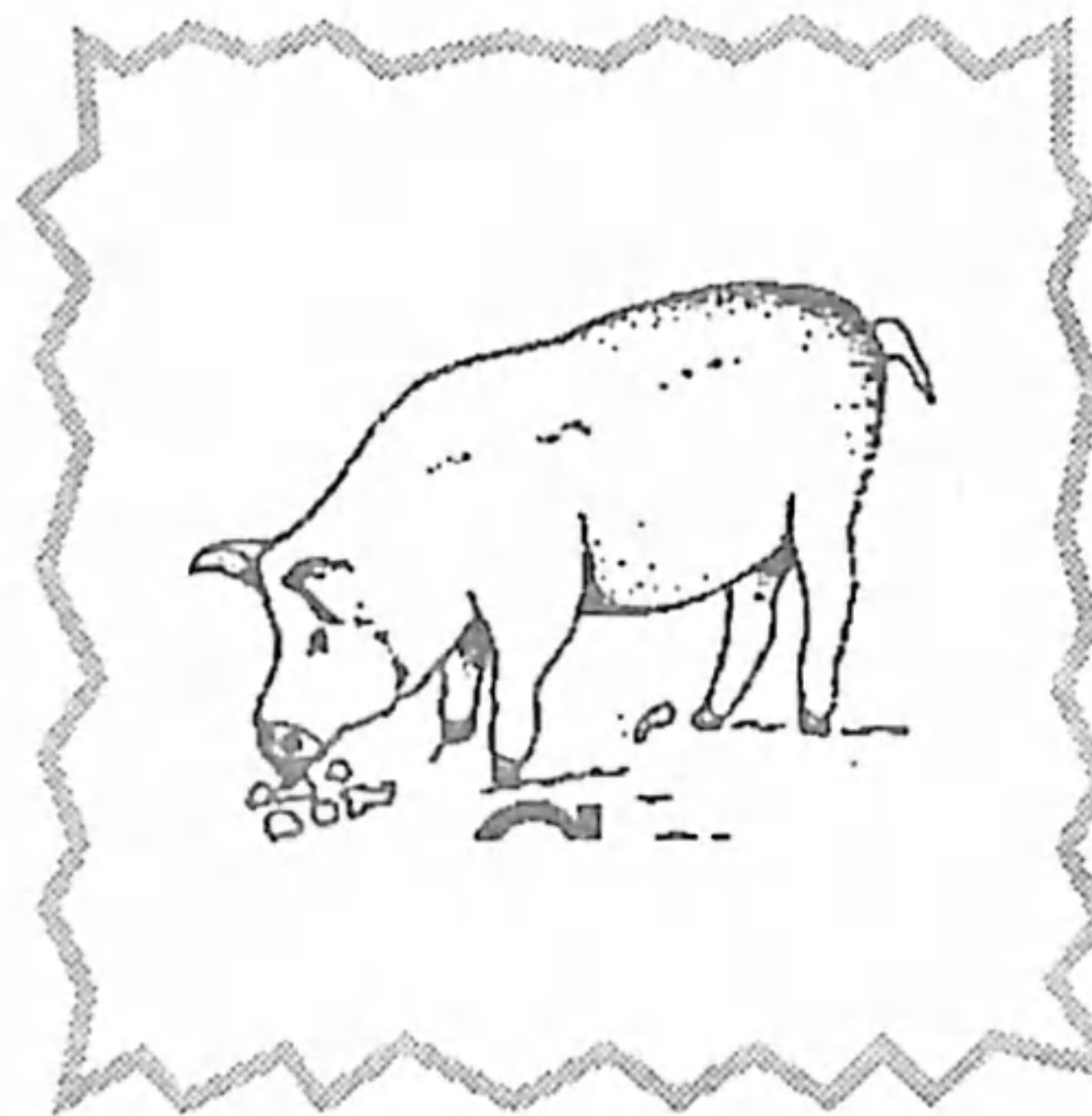

aq



kuk



utiw



k'oy

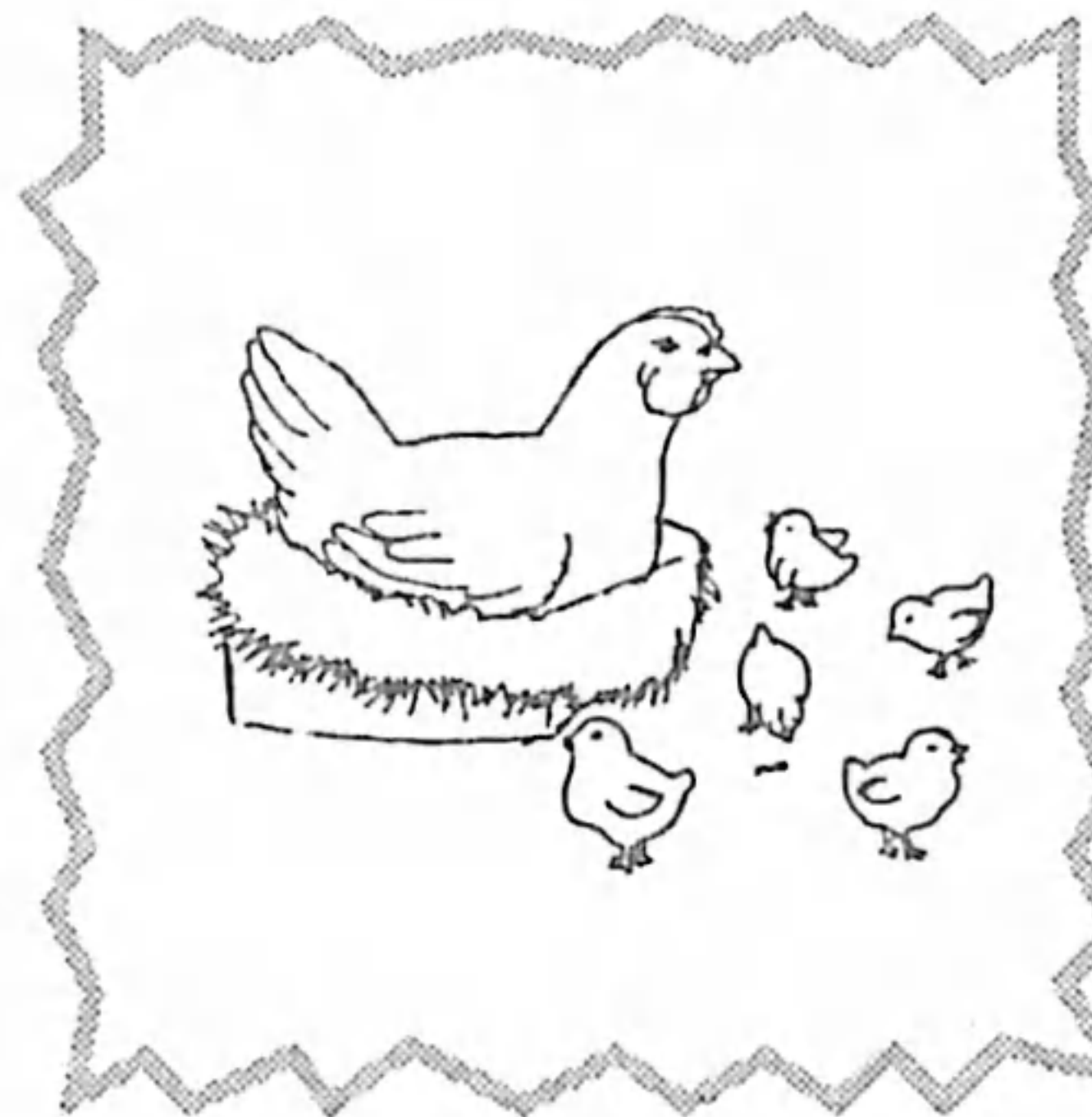

äk'

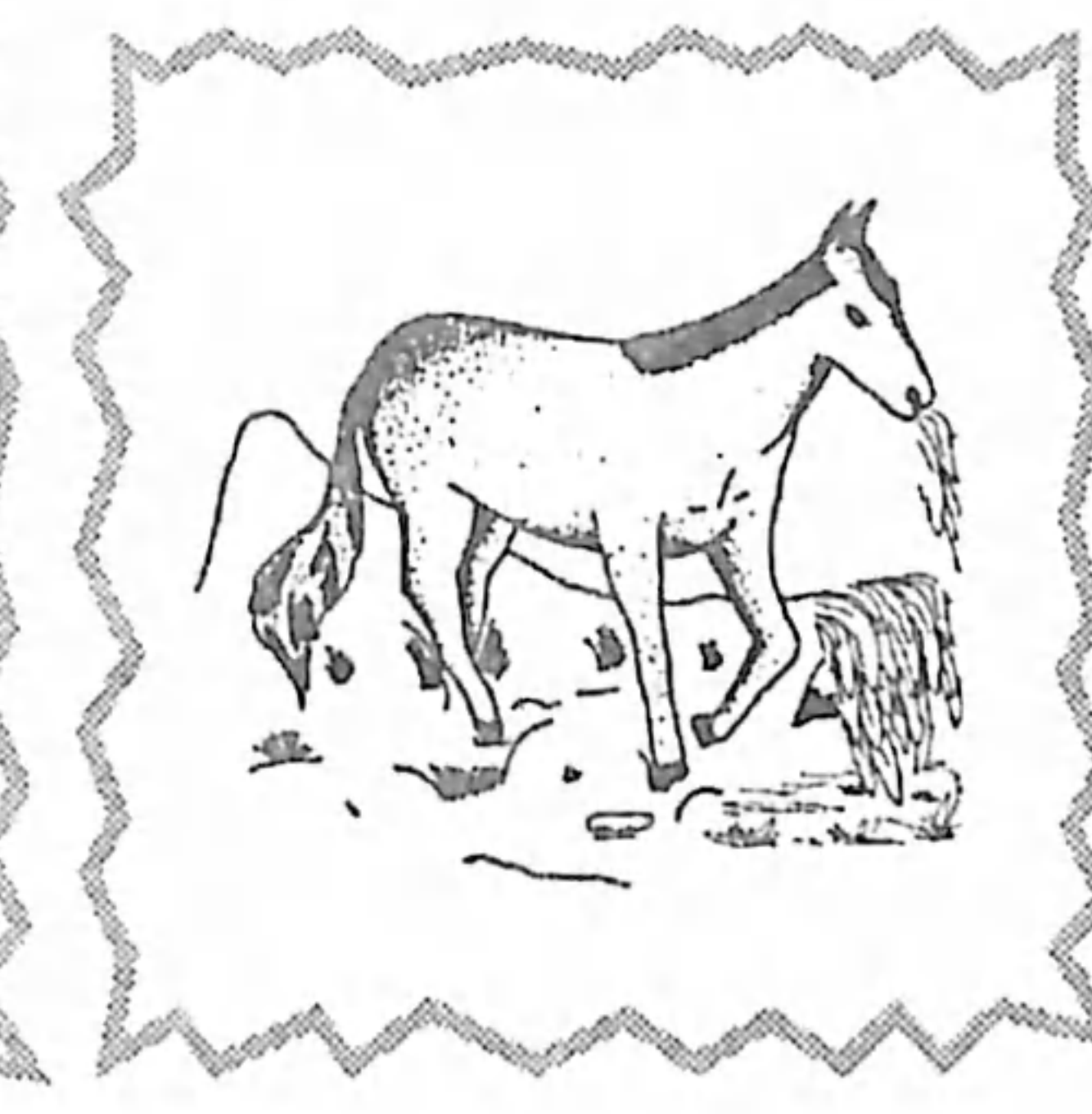

kej

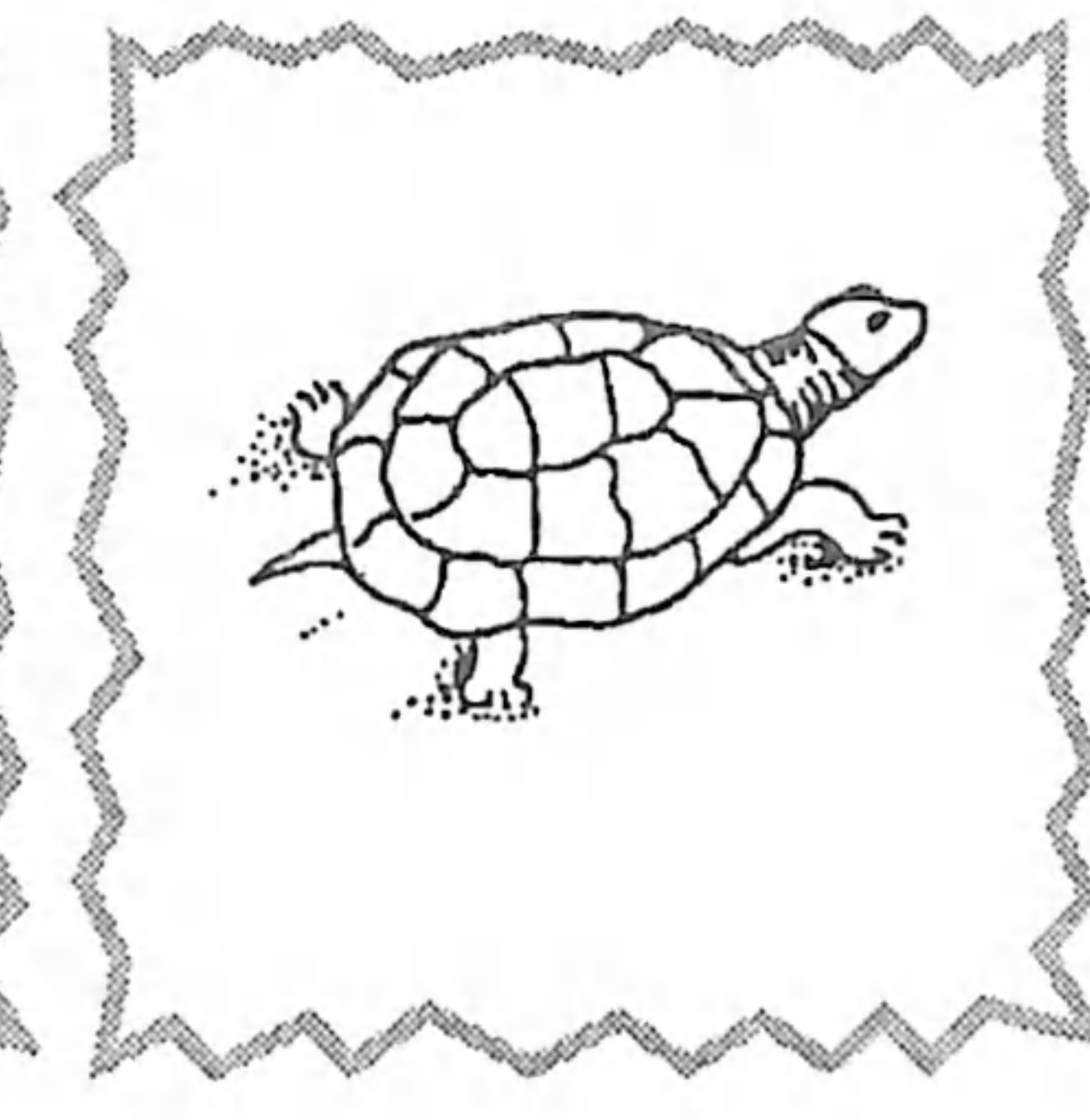

kök



umül

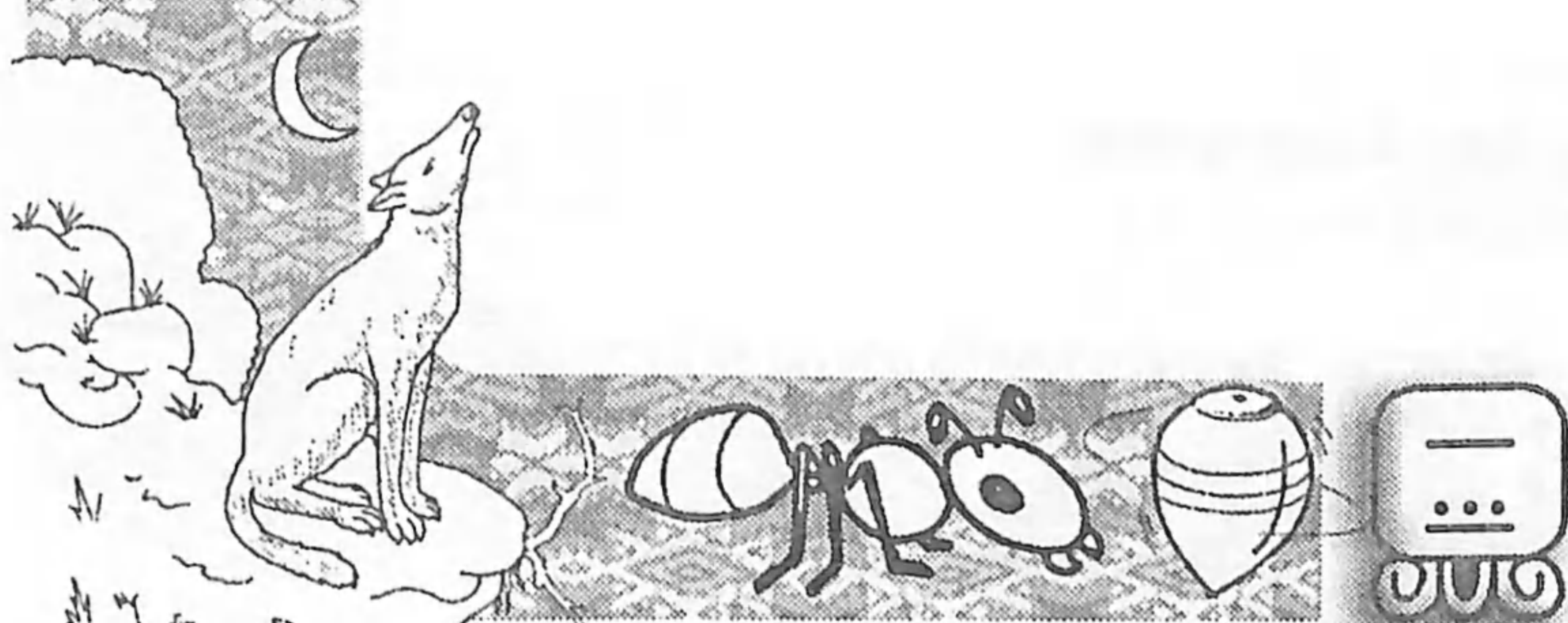

Chi kixe' jujun taq achib'äl keqatz'ib'aj jarupe' chikopi' e k'o chupam ri jujun chakäch

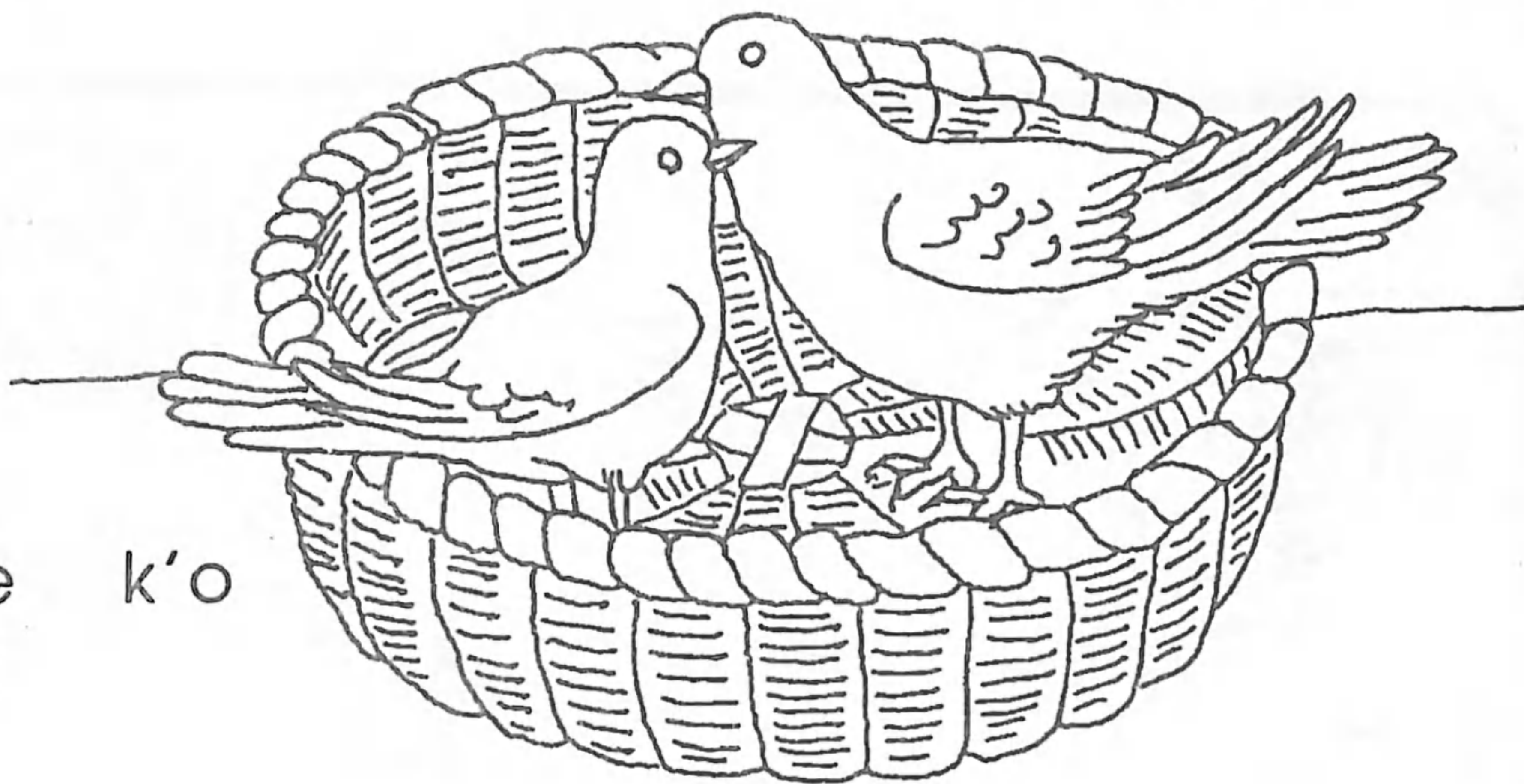

Jarupe' taq ut e k'o chupam ri chakäch

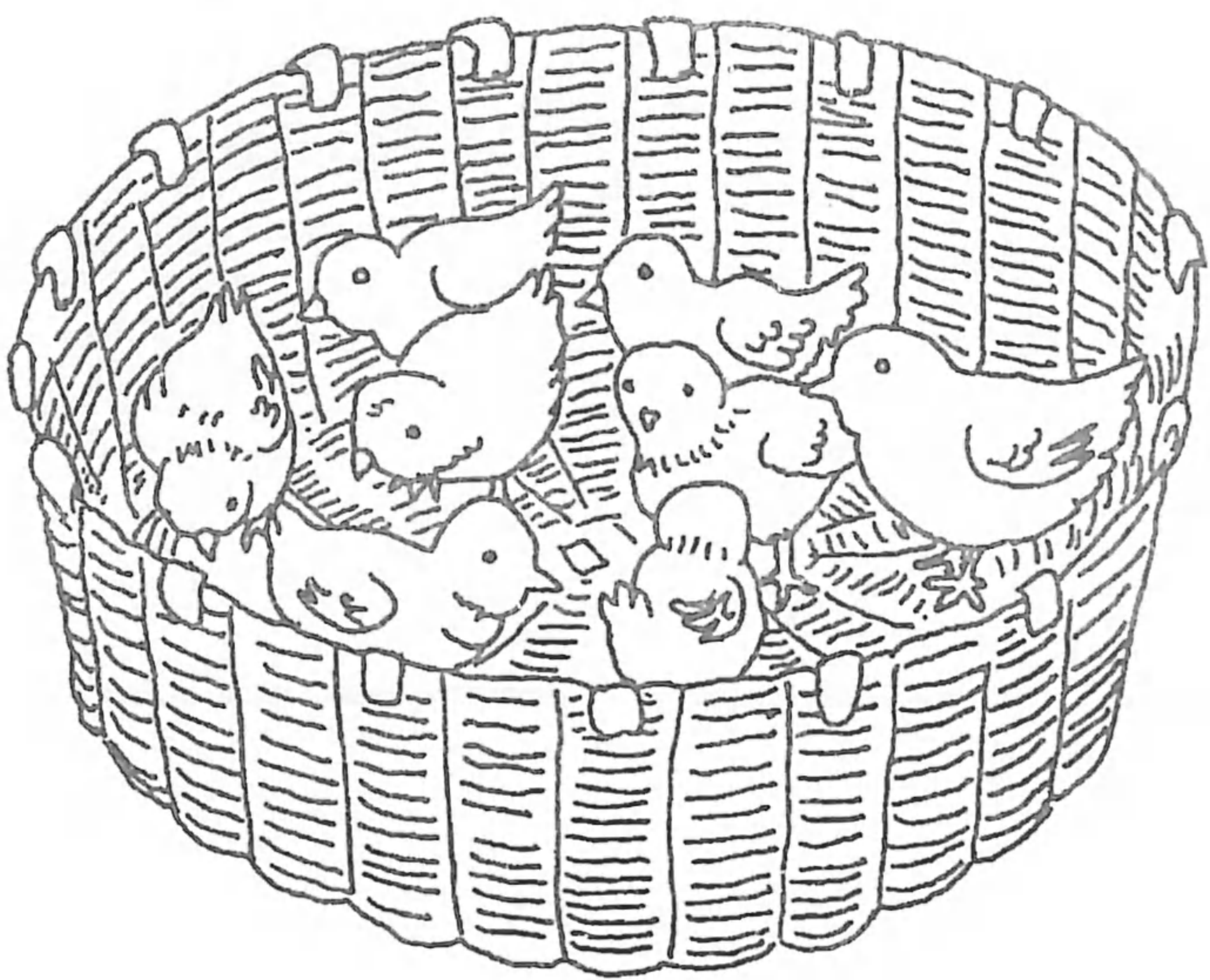

Jarupe' taq äk' e k'o chupam ri chakäch



Jarupe' chikopi' e k'o chupam ri k'ichelaj

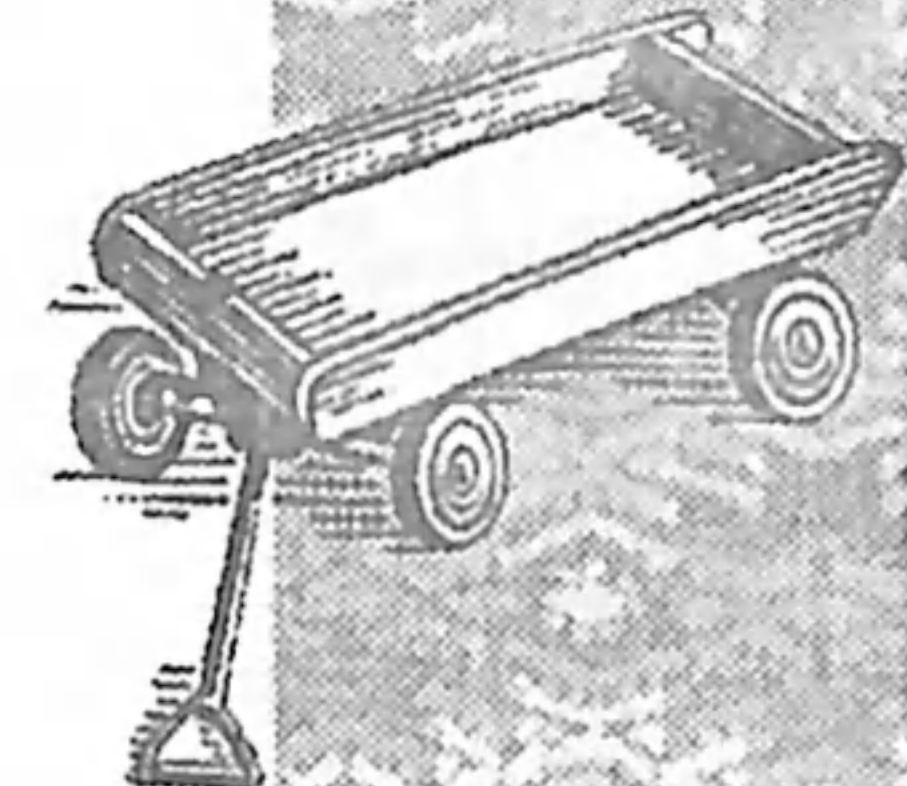

Ri tijoxela' nkib'ij pe jarupe' taq chikopi' e k'o chupam ri taq achib'äl, chuqa' k'o chi nkib'ij kib'i' ri chikopi'.



# Solojsamaj

Ke'awajilaj jarupe' chikopi' e k'o chupam re jun achib'äl re'.

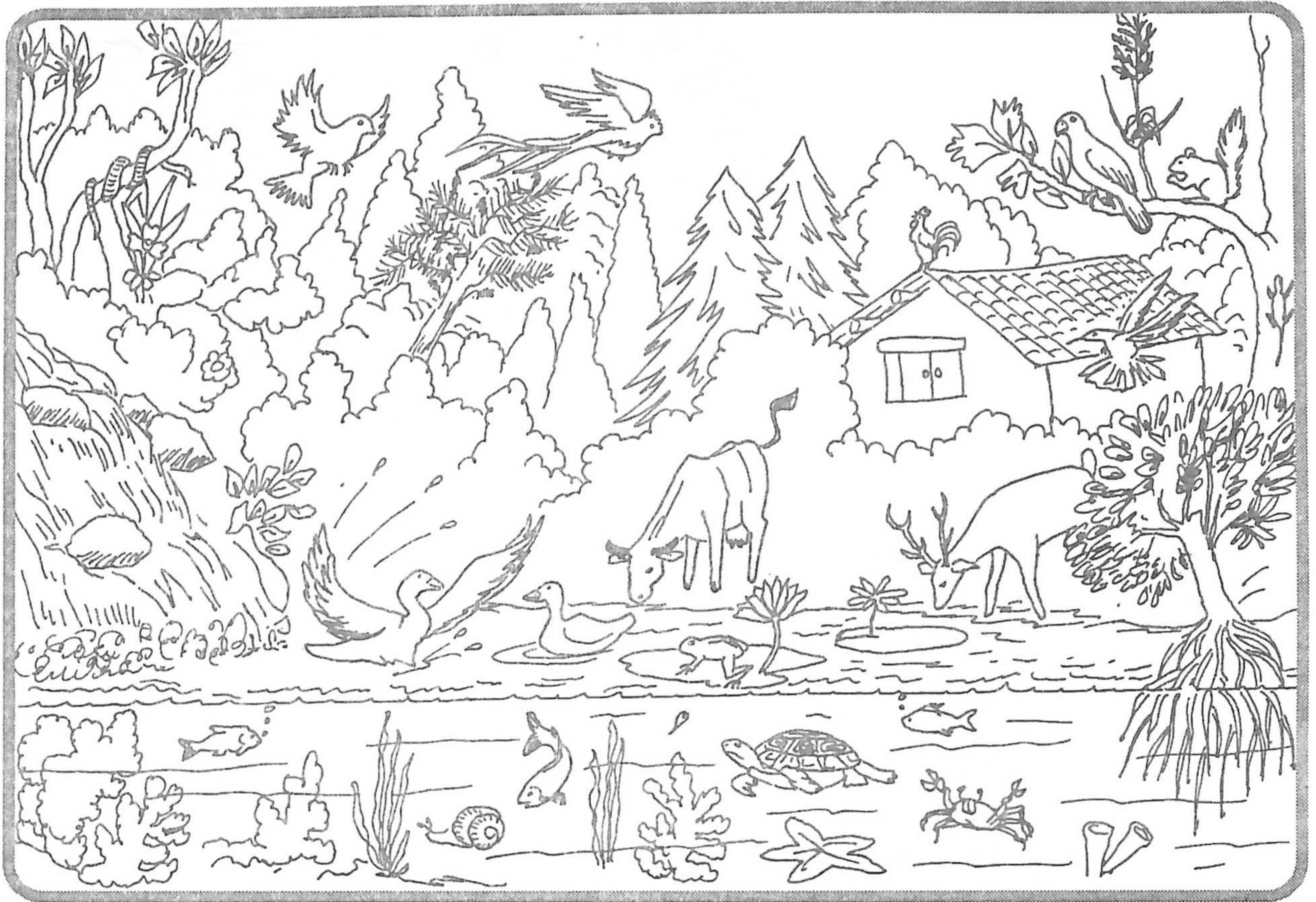

Tatz'ib'aj kib'i' konojel ri chikopi' e k'o chupam re  
jun achib'äl re': \_\_\_\_\_

Jarupe' chikopi' e k'o chuwäch ri achib'äl \_\_\_\_\_

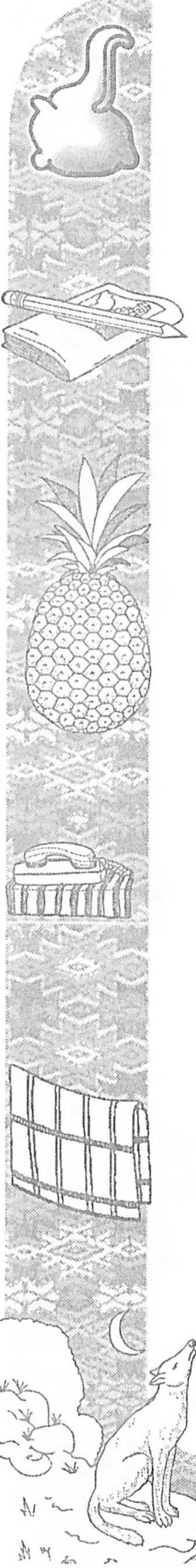

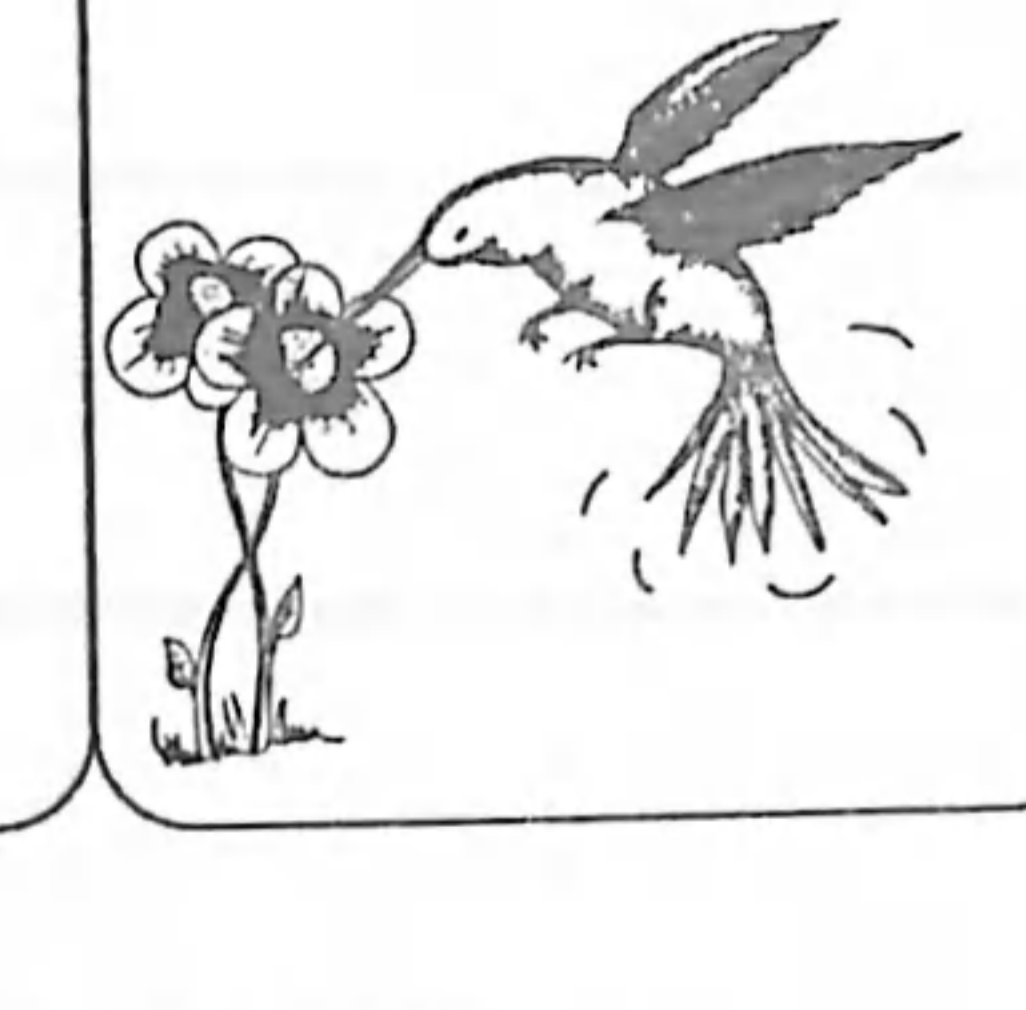
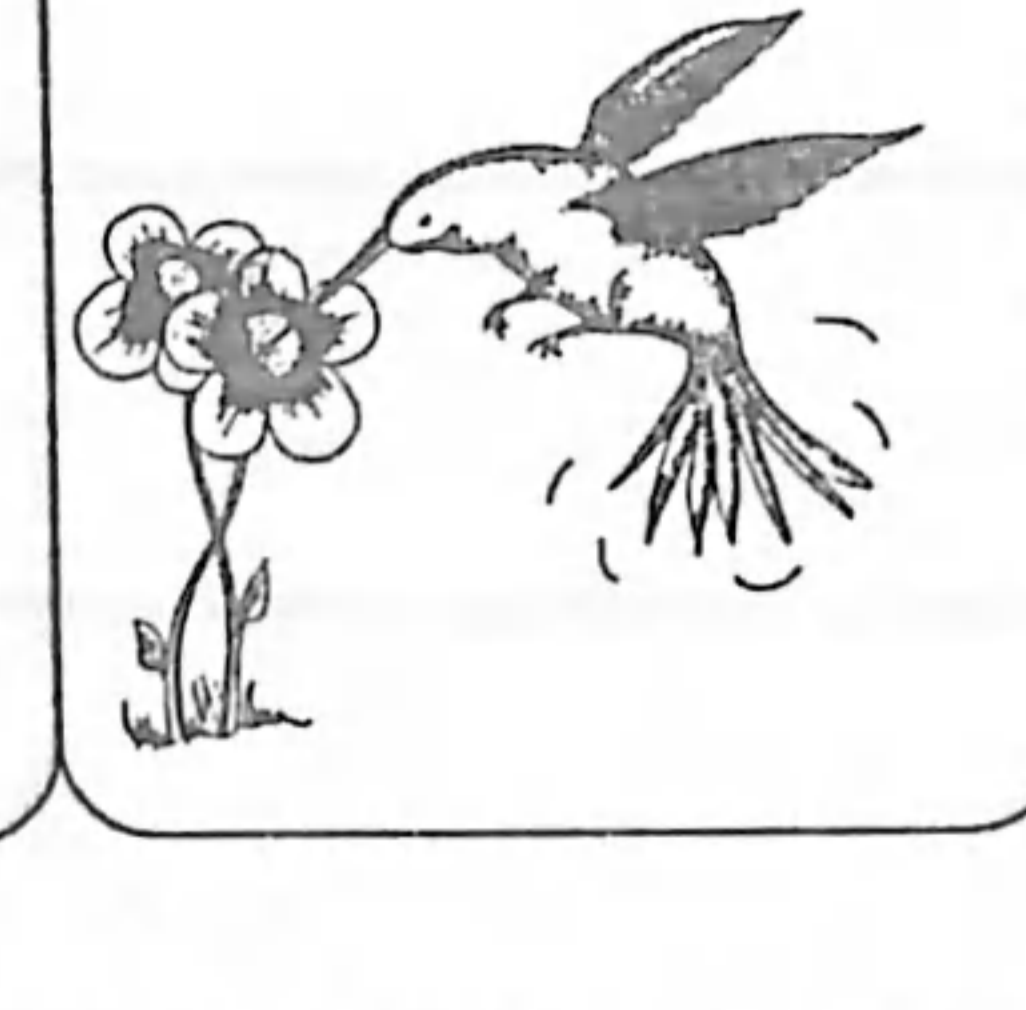
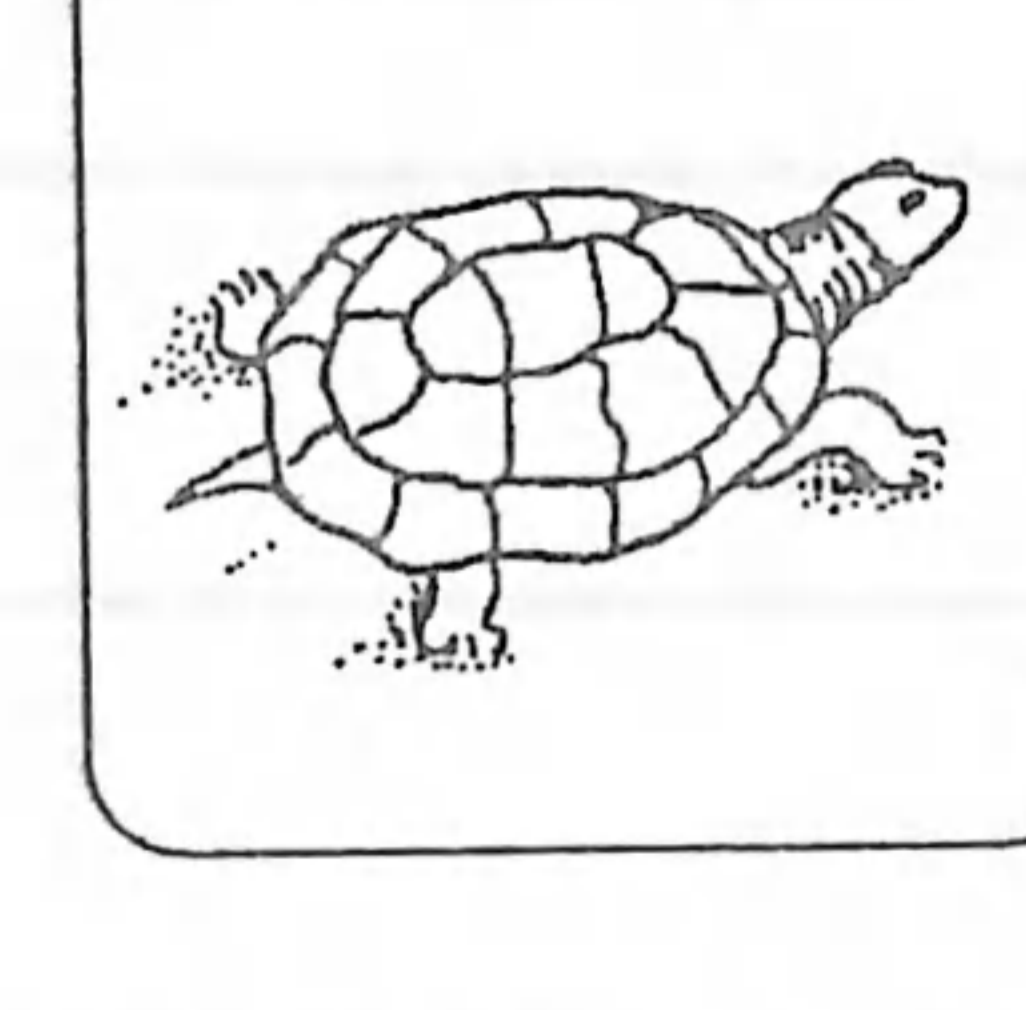
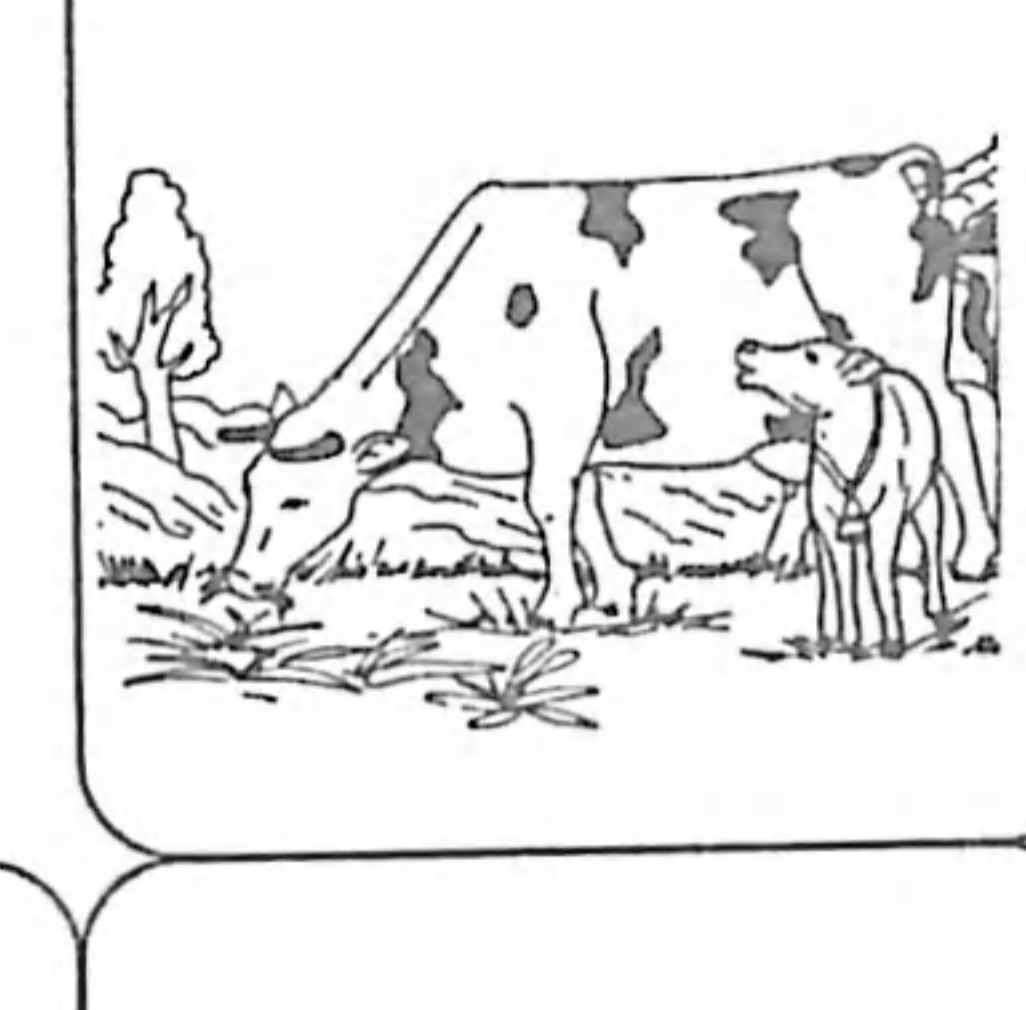
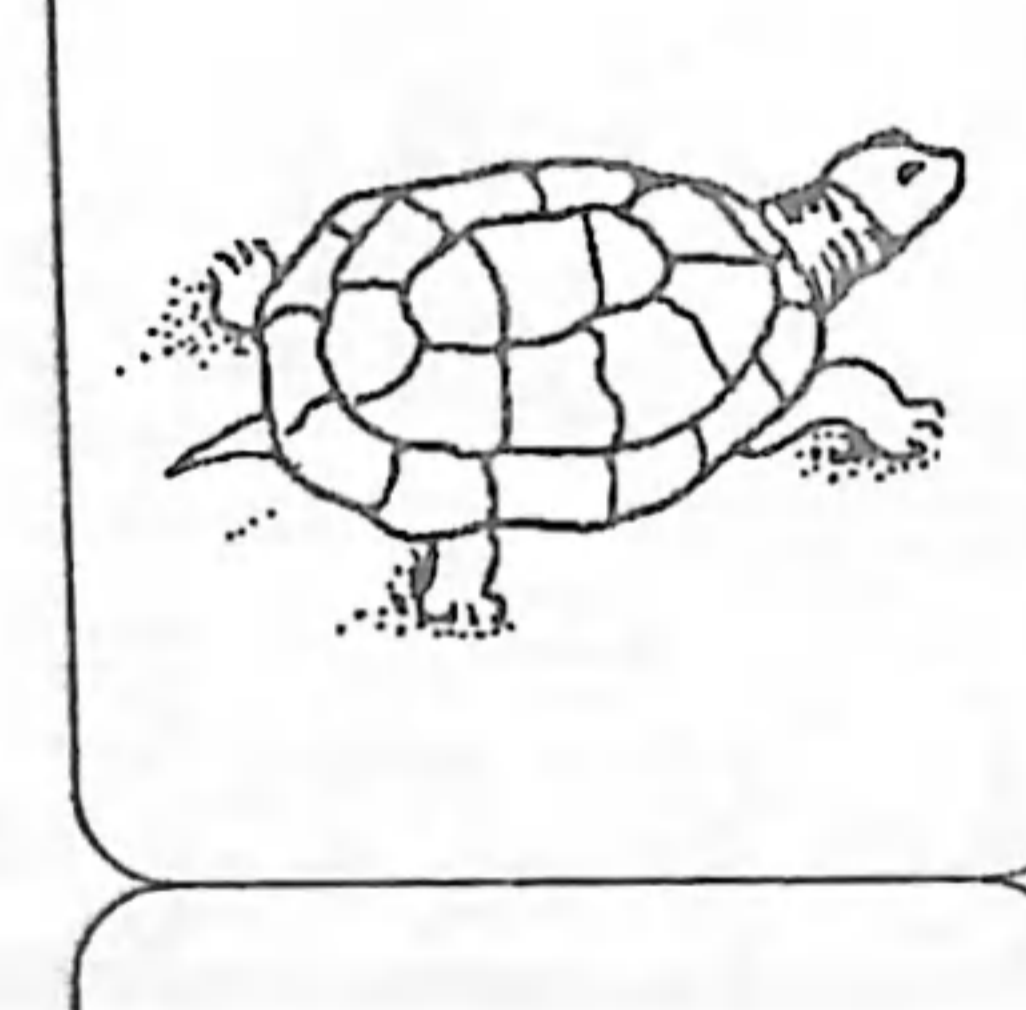
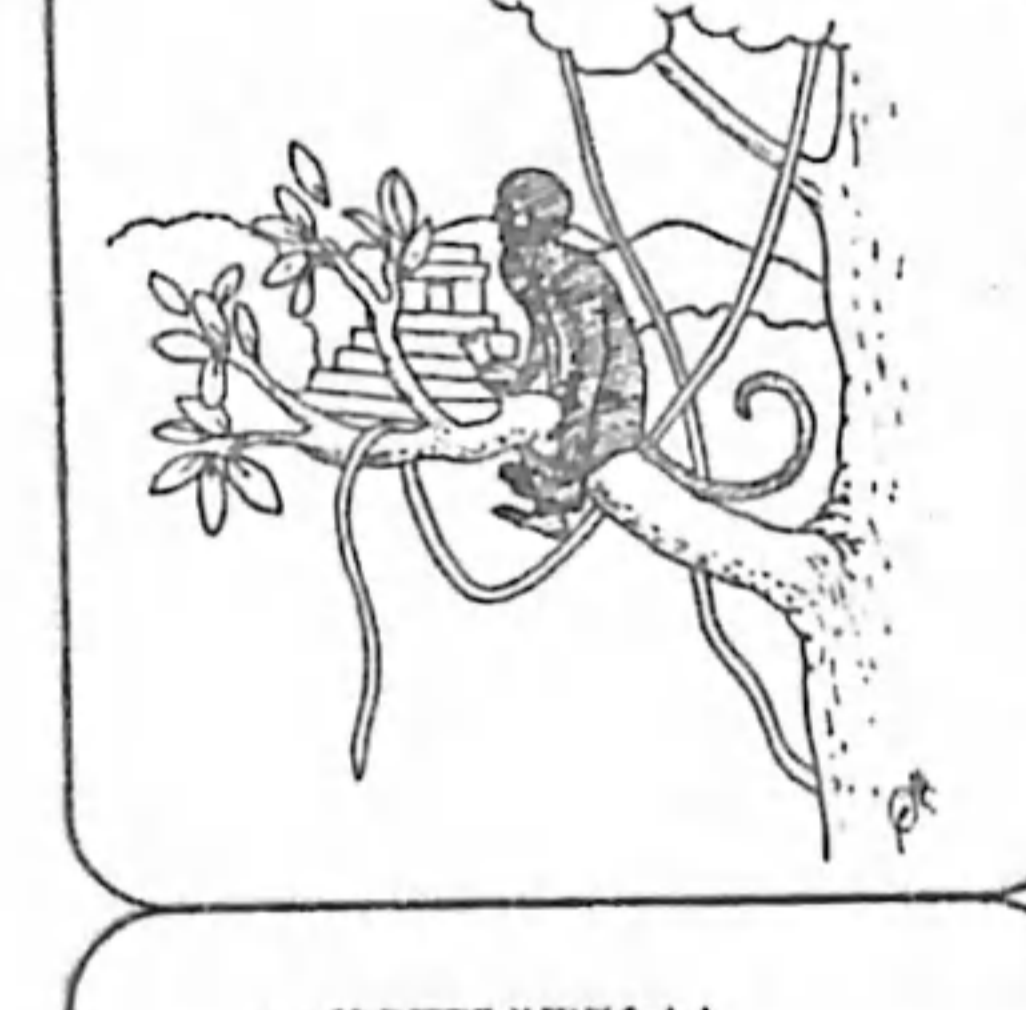
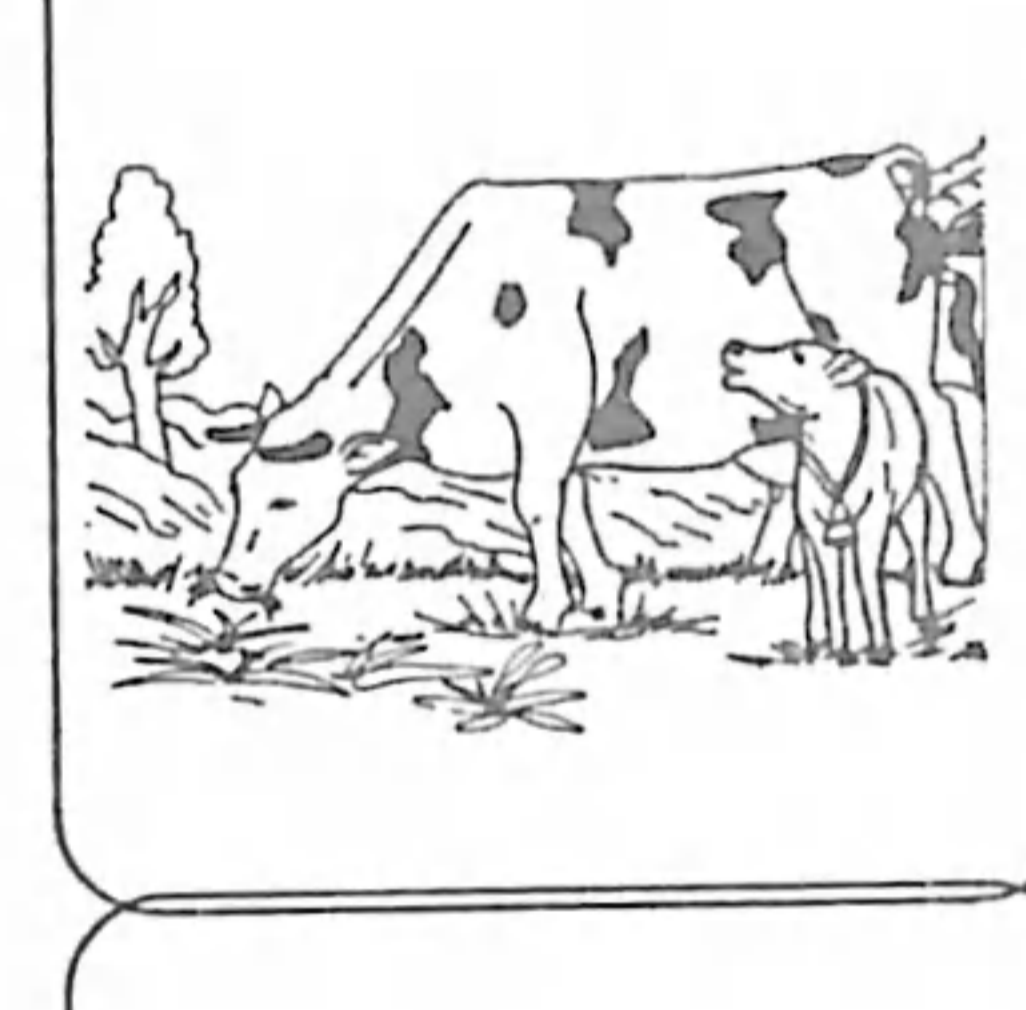

Ri lijoela' nkikanoj kachib'il jujun chikopi' richin ye'elz'an kik'in, likirel nkib'ij kib'i', chuqa' akuchi' e k'äs we.

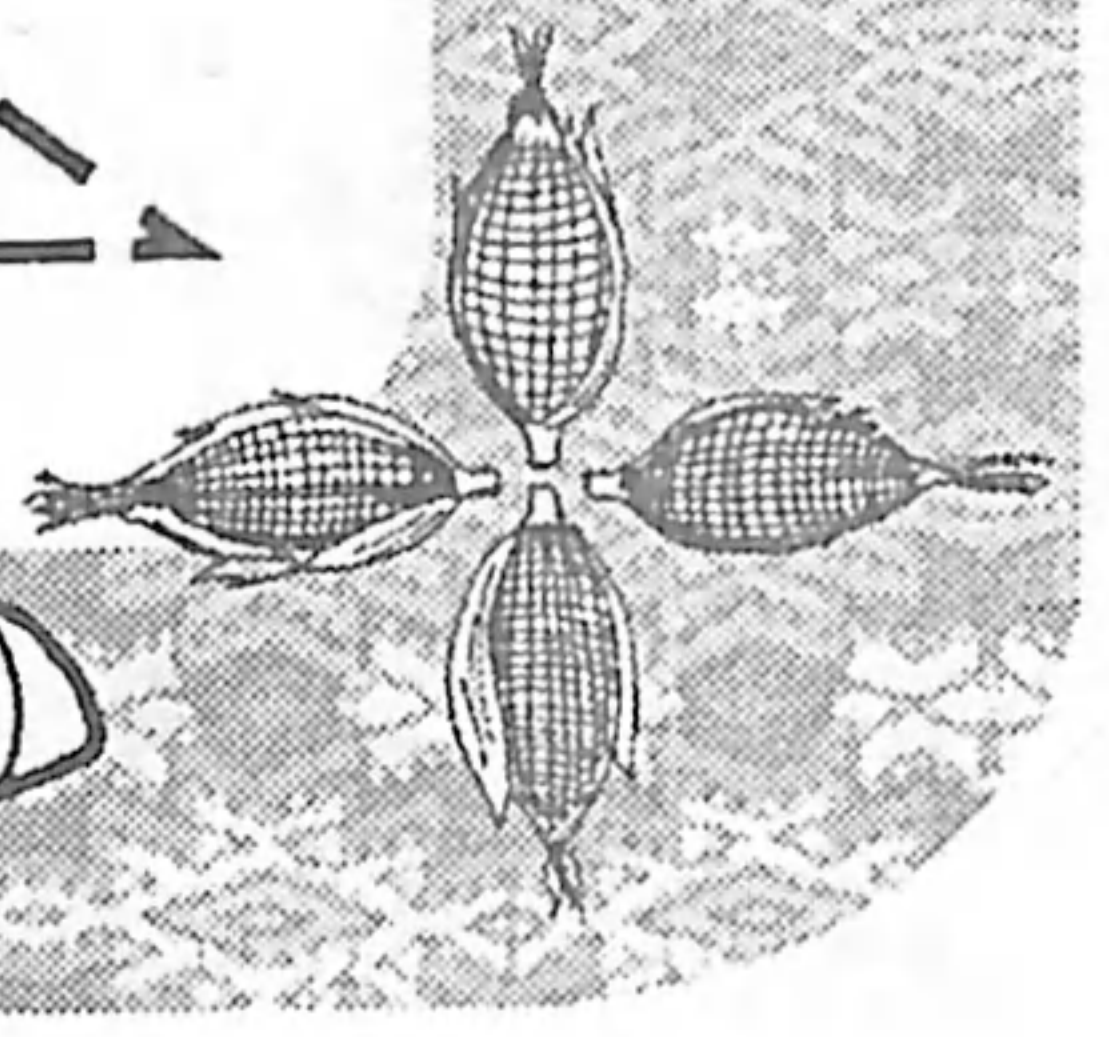





# Tojtob'enik

Keqab'onij ri chikopi' yek'ase' chuwajay:

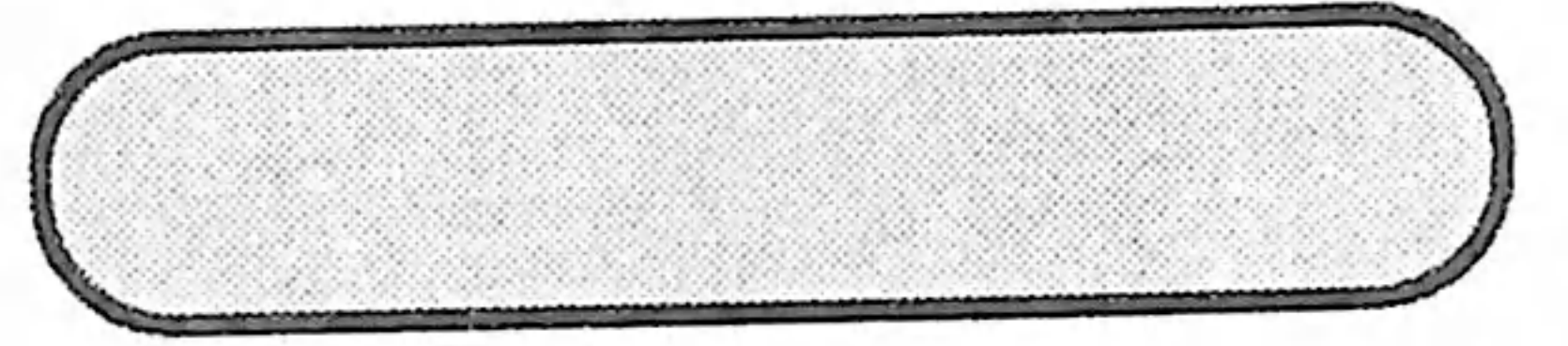
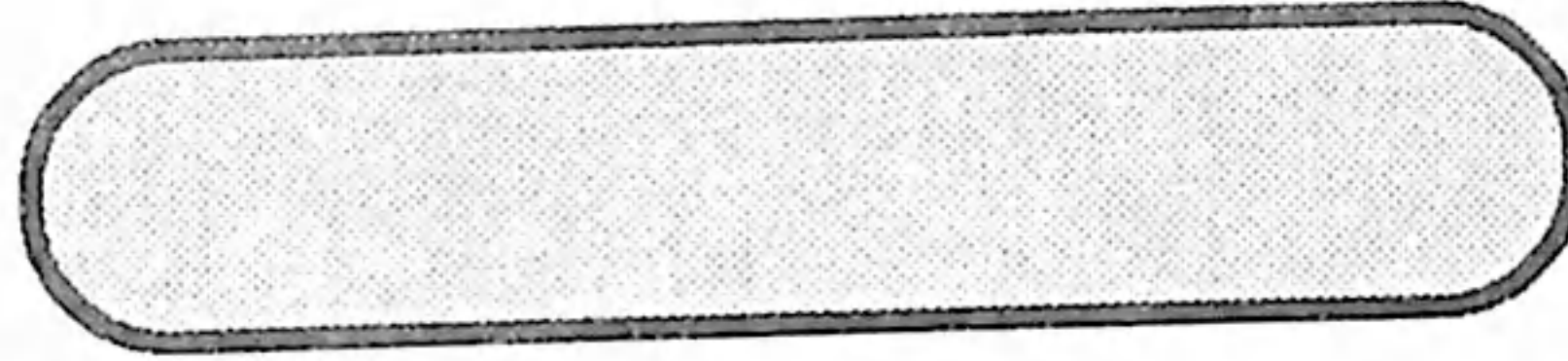
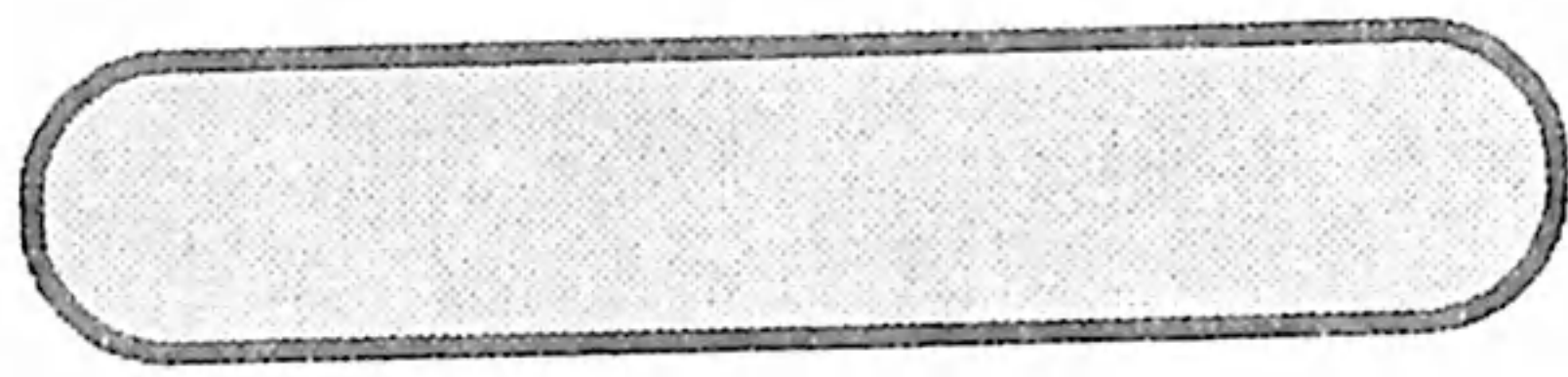

Tatz'ib'aj kib'i' ri  
chikopi' ye'atz'ët  
chuwäch re jun  
achib'äl re'.

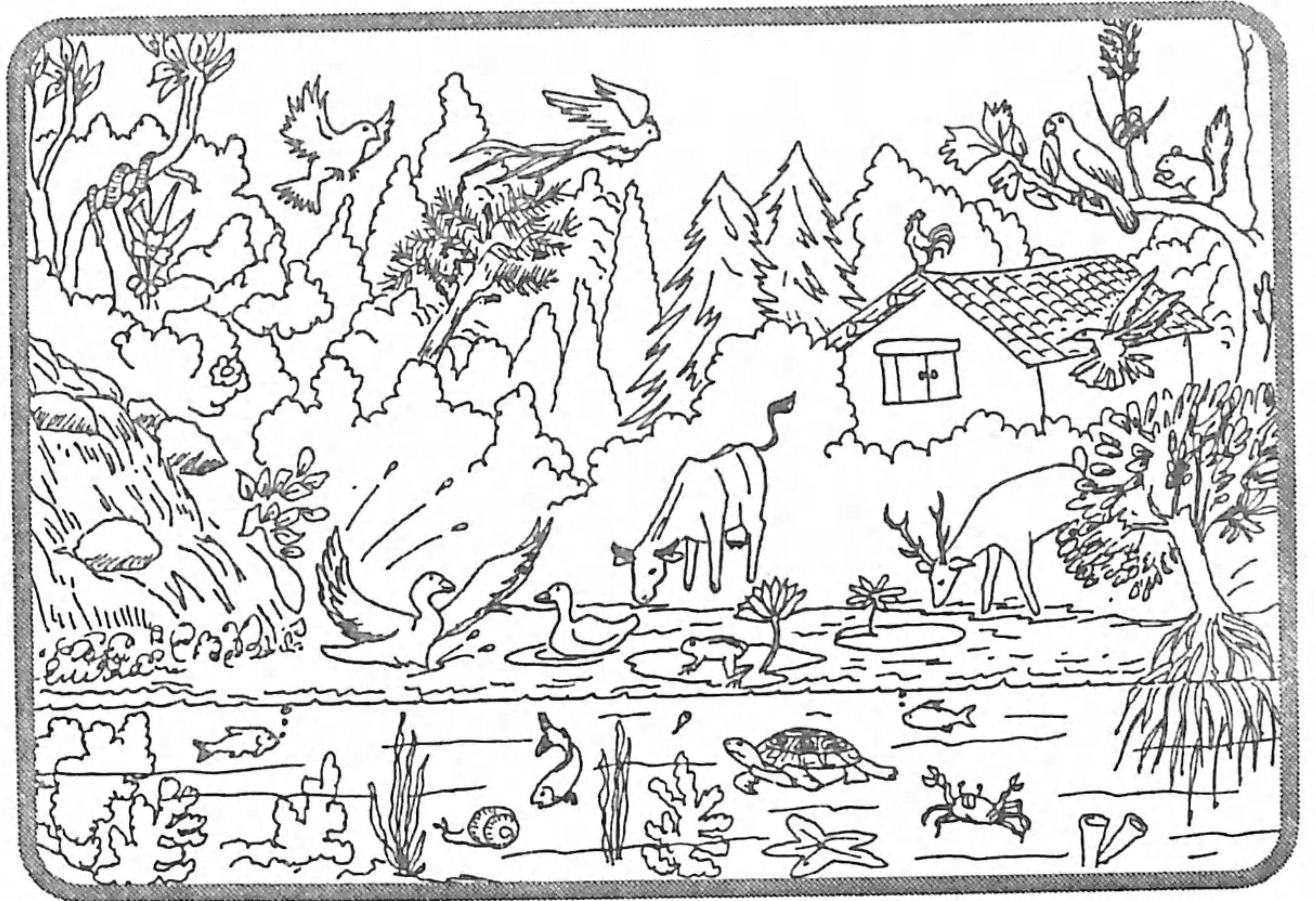

---



---



---

¿Jarupe' chikopi' ye'atz'ët chupam ri achib'äl?



# Choltzij



Ach'alal .....	familia	Pamaj .....	estómago
Ach'alal ri'il .....	familia	Nik'aj ch'akulaj, .....	cadere
Ajtz'aaq .....	albañil	Rutza'm achäq .....	muslo
Ajtz'ib' .....	secretaria o escritor	Ruwi' aqanaj .....	dedos de los pies
Ala's .....	muñeca (o)	Nik'aj wachaj .....	frente
Aq'omabäl jay .....	centro de salud, Clínica, Hospital	Nimajay .....	sala, salón
Aq'omanel .....	médico	Pach'un tzij .....	poesía
B'onitz'ib'ab'äl .....	crayón	Q'olib'äl .....	pegamento
Ch'utik'ajol .....	sobrino de varón	Ruchaq' .....	hermano menor de varón o mujer
Ch'uti'al .....	sobrino (a) de mujer	Ruq'a' tinamit .....	aldea
Ch'utime'al .....	sobrina de varón	Rute' q'aaq' .....	cocina
Ch'utita' .....	tío	Ruwach'ulew .....	tierra
Ch'utite' .....	tía	Ruxikin jay .....	baño
Nub' .....	sacapuntas	Sik'iwuj .....	libro
Juxb'äl wuj .....	regla	Talutzij .....	emisora, radio
Juch' .....	linea	Tanaj .....	unidad, capítulo
Kelonel .....	pintor	Tawila' na k'a .....	adivinanza
K'amajay .....	dirección	Tijonijay .....	aula
K'amöl b'ey .....	alcalde, director, guía	Tunub'axik achib'äl .	rompecabezas
K'ayinel aq'om .....	farmacéutico	Tzamaj .....	naríz
Molaj .....	grupo	Tzib'äl q'aaq' .....	cerrillas
Näj .....	lejos	Tz'ib'ajay .....	secretaría
Telemaj .....	hombro	Tz'ib'awuj .....	cuaderno
Q'ab'aj .....	mano	Tz'ibaxik .....	escritura
		Tz'uj .....	punto
		Wa'ix .....	cero

Warab'äl jay ..... dormitorio  
Wayb'äl jay ..... comedor  
Atok'är ..... barrilete  
Xokon ..... izquierda  
Yakb'äl pwäq ..... banco  
Yakb'äl wachinäq .... bodega  
Yakwuj ..... biblioteca  
Yojb'äl ..... borrador,  
almohadilla  
Jiq'ob'äl..... fruta  
Ruwäch ichaj ..... verdura  
Alanx ..... naranja

Kaqaq'oq' ..... sandía  
Nimatuaq' ..... uva  
Tura's ..... durazno  
Nimamixku' ..... manzana:  
Kaqaqayib'. ..... ciruela:  
Saqsöj ..... gris  
Ayin ..... lagarto  
Masat ..... venado  
Kök ..... tortuga  
K'oy ..... mono  
B'alam ..... tigre

## Ri sik'iwuj xenik'ox richin xelesäx na'oj chi kipam



- ◇ Chacach Martín: “Ri Samaj Ruxe’el ri Kikotem” Colección “Materiales Educativos No. 18, Universidad Rafael Landívar, Instituto de Lingüística. Guatemala, 1992.
- ◇ DIGEBI/MINEDUC: “Kojnojin, Matemática Kaqchikel”. Primer Grado. Área Lingüística Kaqchikel. Guatemala C. A. 2001.
- ◇ Asociación de Amigos del País, Programa de Educación Básica Integral. Educación Extraescolar.
- ◇ Aprendamos Juntos. Libro del Niño. Iris Joyce Winner, Mireya Cano, Peggy Batrós. Alfalit, Internacional, Inc.
- ◇ True Colors. An EFL Course for Real Communication. JAY MAURER IRENE E. SCHOENBERG.
- ◇ Las Criaturas del Aire. Un día en la vida del abuelo, la Luciérnaga, la Palomilla y el ronron. Gerardo Guinea D y Víctor Herrera. Visión Guatemala.
- ◇ Ruka’n Sik’iwuj richin Retamaxik ri Kaqchikel Ch’ab’äl. Proyecto Niñez y Juventud Kaqchikel por una Educación Bilingüe Intercultural. Hacia la Paz y Desarrollo de Guatemala, 1,988 – 2001. Kaqchikel Moloj/Fundación Kaqchikel.
- ◇ Ri Chikopi’ pa Kaqchikel. Juan Yool Cúmez. Universidad Rafael Landívar. Instituto de Lingüística, Guatemala, 1,990.



*Programa de Educación Bilingüe Intercultural:  
Incidencia en la Reforma Educativa desde el aula  
Contrato de subvención N° ONG-PVD/2002/020-679*

Con el apoyo de:

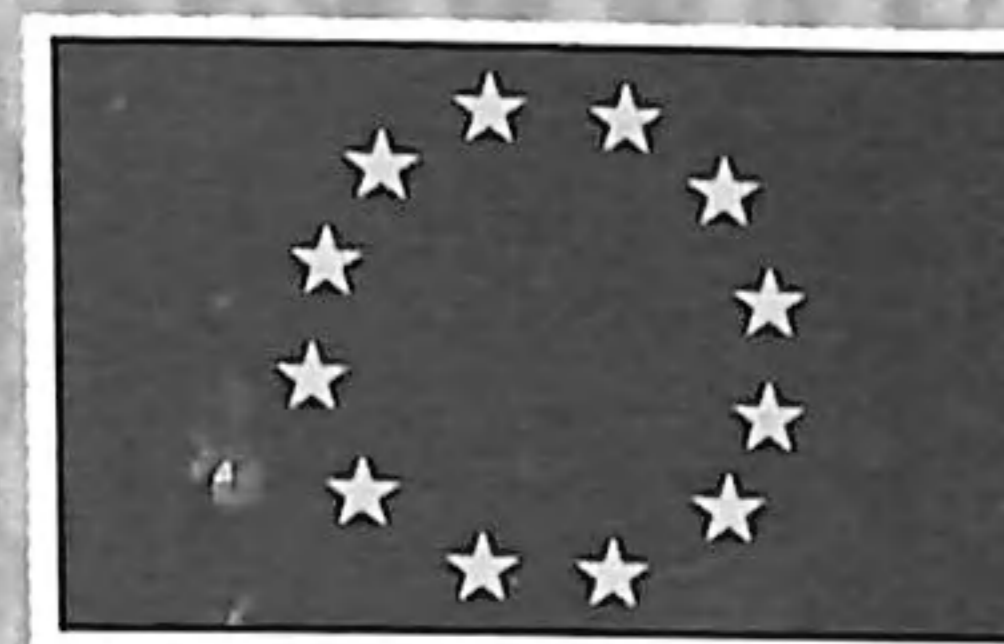

UNION EUROPEA

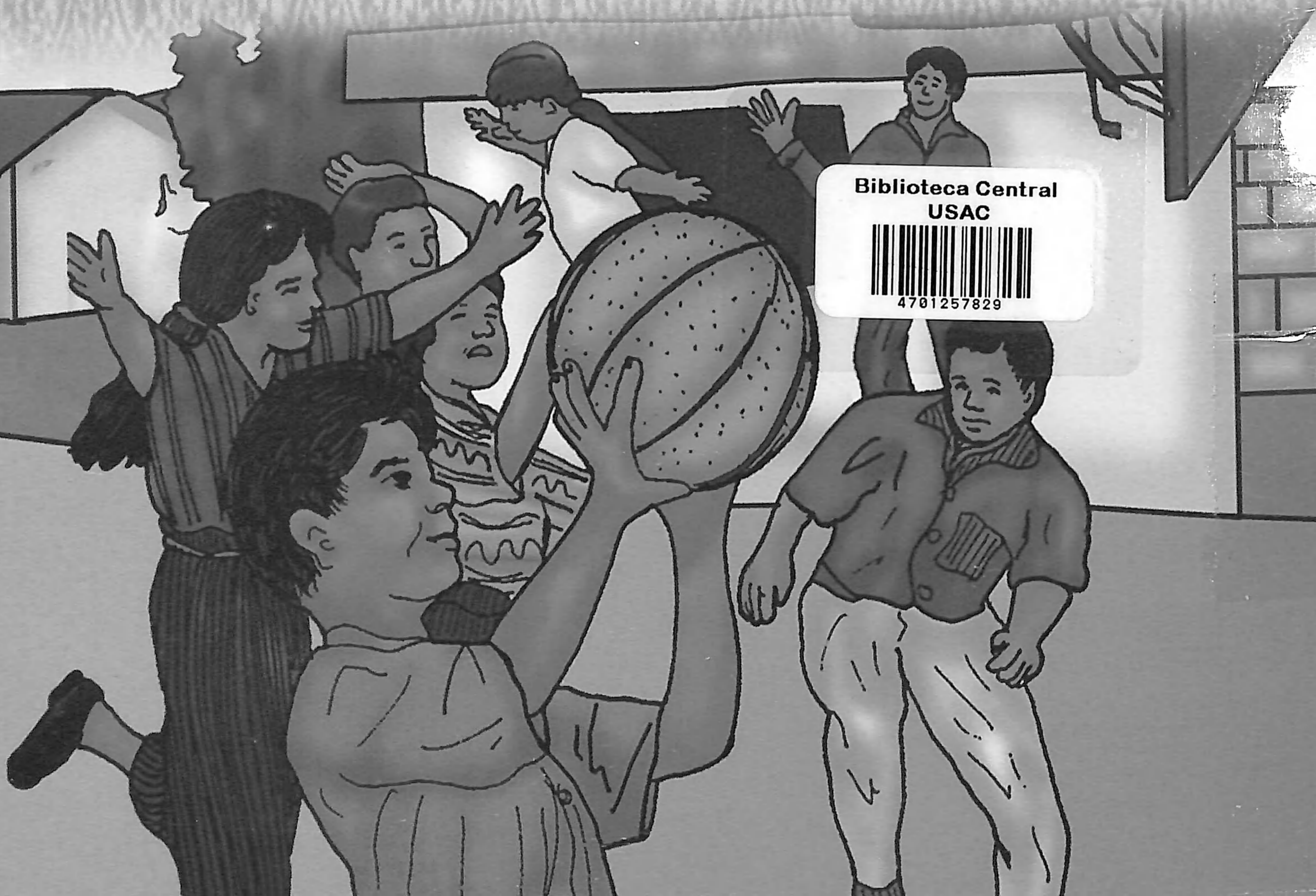

Biblioteca Central  
USAC



4701257829